



Fiber Delivered Direct Diode Lasers User Guide

RFL-A3000D

TABLE OF CONTENTS

1 Safety Information.....	3
1.1 Symbols Used in this User Guide.....	3
1.2 Laser Classification.....	3
1.3 Safety Labels.....	4
1.4 Optical Safety.....	5
1.5 Electrical Safety.....	6
1.6 Other Safety Rules.....	6
2 Product Description.....	6
2.1 Features.....	6
2.2 Model Configuration.....	7
2.3 Package Contents.....	8
2.4 Unpacking and Inspection.....	8
2.5 Operation Environment.....	8
2.6 Matters Need Attention.....	9
2.7 Specifications.....	10
3 Installation.....	11
3.1 Dimensions.....	11
3.2 Output Head and Installation.....	13
3.3 Cooling Requirements.....	13
3.4 Installation Procedure.....	14
4 Using the Product.....	15
4.1 Front/Rear Panel.....	15
4.2 Power Connection.....	18





4.3 Interface Definitions.....	18
4.4 Installation Sequence.....	23
4.5 Process for Starting the Laser.....	23
4.6 Control Mode Selection.....	23
4.7 Red light control.....	27
4.8 Shutdown operation sequence.....	28
5 Alarms and Solutions.....	28
5.1 Alarms Display.....	28
5.2 Alarm Solutions.....	28
6 Warranty, Return and Maintenance.....	30
6.1 General Warranty.....	30
6.2 LimitationsofWarranty.....	30
6.3 Service and Repair.....	31

1 Safety Information

Thank you for choosing Raycus fiber laser. This User Guide provides important, safety, operation, warranty and other information. Please read it carefully before you use this product. In order to ensure safe operation and optimal performance of the product, please follow the warnings, cautions, operating procedures and other instructions accordingly.

1.1 Symbols Used in this User Guide

	◆ Refers to a potential hazard that may lead to a personal injury or death.
---	---

	◆ Refers to potential a hazard that may lead to a minor personal injury or product damage.
--	--

1.2 Laser Classification

This series of lasers are classified as a high power Class 4 laser instrument according to the European Community standards EN 60825-1, clause 9. This product emits invisible laser radiation at or around a wavelength of 915 nm, and the total light power radiated from the optical output is greater than 3000W (depending on model). Direct or indirect exposure of this level of light intensity may cause damage to the eyes or skin. Despite the radiation being invisible, the beam may cause irreversible damage to the retina and/or cornea. Appropriate and approved laser safety eyewear must be worn all the time while the laser is operating.

	◆ You must use appropriate laser safety eyewear when this device is operating. The laser safety eyewear is selected according to the range of wavelengths emitted from this product. The end user must ensure that the laser safety eyewear being used protects against light emitted by the device over its entire range of wavelengths. Please verify that the personal protective equipment (e.g. enclosures, viewing windows or viewports, eyewear, etc.) being utilized is adequate for the output power and wavelength ranges listed on the product.
---	--

1.3 Safety Labels

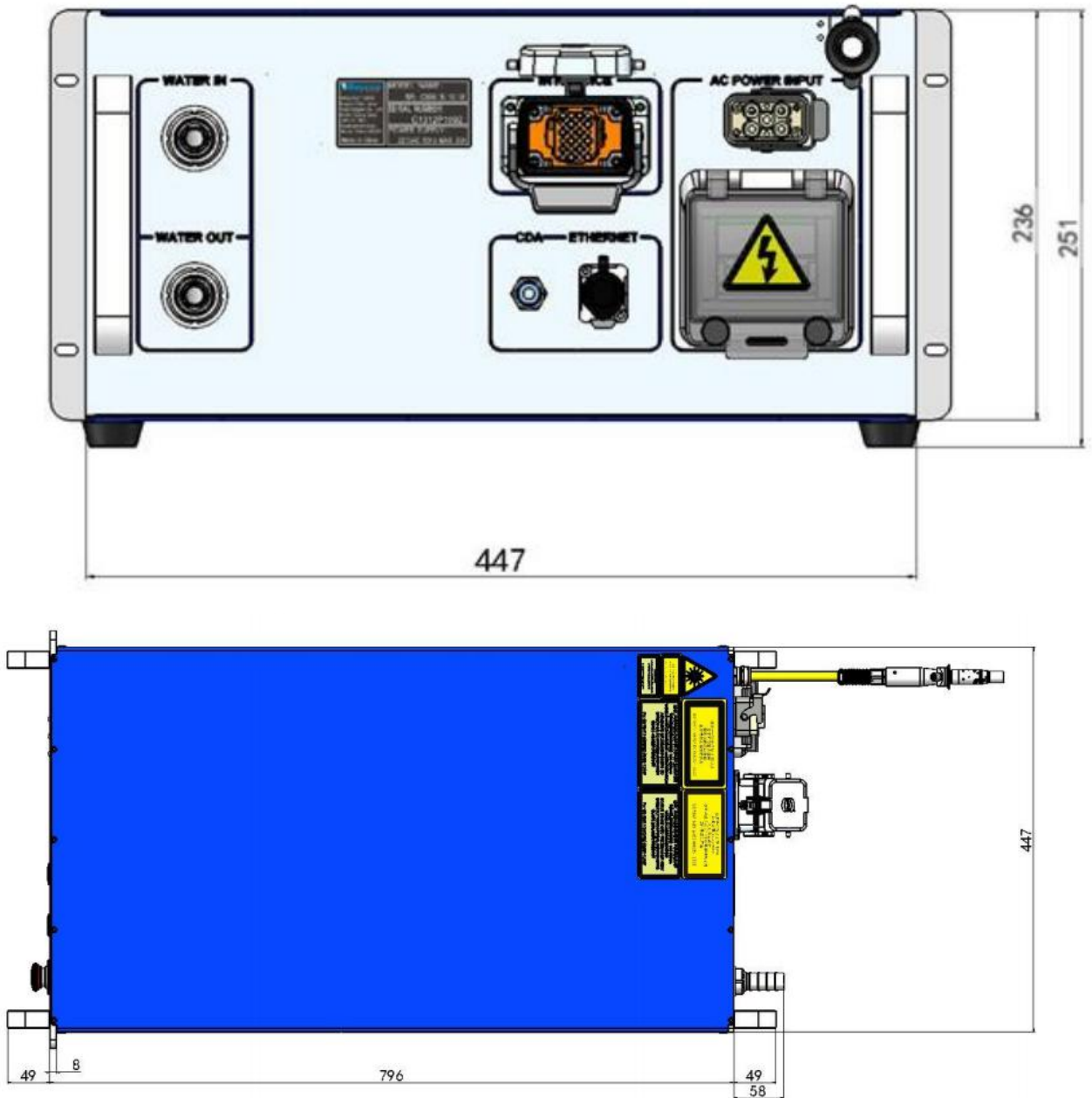

Figure1 Top View and Back View

Figure 1 shows the product safety labels and its location. These safety signs include: safety warnings, laser output head warnings, product nameplates, etc. The safety identification details are as follows:

Table1 Safety Identification

<p>a) Laser Radiation Hazard</p>	<p>b) Aperture Label</p>	<p>c) Aperture Label(CN)</p>
<p>d) Class 4 Laser Product(EN)</p>	<p>e) Class 4 Laser Product(CN)</p>	<p>f) Class 2M Laser ProductLabel for Guide Laser(EN)</p>
<p>g) Class 2M Laser ProductLabel for Guide Laser(CN)</p>	<p>h) Electrical Hazard Label</p>	<p>i)Product Nameplate</p>

1.4 Optical Safety

Any dust on the end of the collimator assembly can burn the lens and damage the laser.

	<ul style="list-style-type: none"> ◆ If the output of the device is delivered through a lens without anti-reflection coating, make sure that the lens is of good quality and clean.
--	--

1.5 Electrical Safety

Make sure your product is grounded through the PE line of the AC power cord. The grounding must be firm and reliable.

	◆ Any interruption from the protective earth will electrify the enclosure, which may result in personal injury.
---	---

Make sure that the correct voltage of the AC power source is used.

	◆ Failure to connect the correct voltage could damage the product.
---	--

1.6 Other Safety Rules

- a) Never look directly into the laser output port when power is supplied to the laser.
- b) Avoid using the laser in a dim or darkened environment.
- c) If this device is used in a manner not specified in this document, the protection provided by the device may be impaired and the warranty will be voided.
- d) Do not remove the covers of the laser, or the warranty will be voided. All maintenance must be performed in Raycus or by qualified Raycus personnel.

2 Product Description

2.1 Features

Compared with traditional lasers, Raycus CW fiber diode laser has higher efficiency electric-optical conversion, lower power consumption. The fiber laser is compact and ready to use. Because of its flexible form, it can be easily integrated with the system equipment.

Main Features:

- a) Flexible output optical cable
- b) High reliability and long service life
- c) Maintenance free operation

- d) High photoelectric conversion efficiency
- e) Convenient control interface
- f) High frequency modulation

Main Applications:

- a) Laser-quenching
- b) Laser-cladding
- c) Laser-welding
- d) 3D-printing
- e) Scientific research

2.2 Model Configuration

Fiber delivered direct diode lasers RFL-A3000D, and the model designation codes are illustrated in the following table:

Table 2 Model Names and Designation Codes

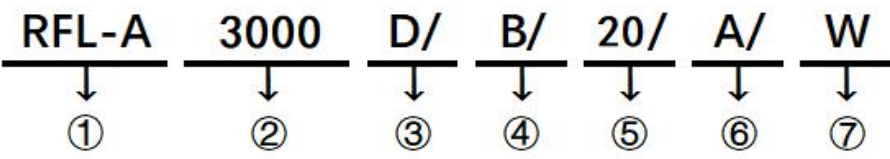
	
1	RFL-A series, Fiber Delivered Direct Diode Laser
2	Power in watts, Output power of 3000W laser
3	laser type, 'D' indicates direct output
4	Wavelength, there have B, C, D, E, which indicate respectively as 915nm,976nm,940nm,808nm
5	Length of delivery cable in meter, 20m, and other length can be customized
6	Interface type of delivery cable, 'A' indicates iHQB interface, 'B' indicates SMA905 interface, 'C' indicates D80 interface
7	Cooling method, 'W' indicates water cooling, 'T' indicates TEC air cooling, 'A' indicates air cooling

2.3 Package Contents

Please refer to the packing list accompanying the shipment to check actual items included.

2.4 Unpacking and Inspection

Raycus ensure that the laser do get adequate protection by special designed packaging material and box during the transit. Even so, In order to prevent the unpredictable component damage, users need to scrutinize the packing box is right before unpacking it whether or not cracking, abrasion, dampened and other phenomena. if there is any abnormality in the box body, Please contact us, we will correct it immediately.

On unwrapping the box, Please check that packing lists and physical goods are the same. If you have any questions, feel free to contact any of us at any time.

When taking the laser out of the box, Avoiding knock against and violent vibration on the laser. When taking optical fiber and output head, In particular, It is not possible to bend, twist and pull optical cable, At the same time should avoid output head suffering the blows and vibrations.

	◆ The fiber optic cable and output head is precise optiinstrument, any vibration or impact to the output head, and twist orecessive bend to the cable will damage the instrument.
---	---

2.5 Operation Environment

The basic operation conditions are listed in the table below:

Table 3Basic Operation Conditions for the Laser

Product Model	RFL-A3000D
Power Source	TN-S, 380±38VAC, 50/60Hz
Power Capacity	10kW
Installation Environment	Flat with no vibration and shock
Ambient Temperature	10~40°C
Relative Humidity	<70%

It is recommended to install the laser in an air-conditioned environment so that the laser can operate under optimal conditions.

	<ul style="list-style-type: none"> ◆ Do not expose this product to high humidity (>70%). ◆ Do not expose this product to high temperature (>40%). ◆ Do not let this product work below the ambient dew point temperature.
---	--

Table 4The Constant Dew Point Table

AMBIENT DEW POINT						
Ambient Temperature(°C)	Maximum Relative Humidity					
	20%	30%	40%	50%	60%	70%
20	-3.5	2	6	9	12	14.5
25	0.5	6	10.5	14	16.5	19
30	4.6	10.5	15	18.5	21.5	24
35	8.5	15	19.5	23	26	28.5
40	13	20	24	27.5	31	33

The necessary moistureproof treatment has been done in the design of the laser, but the influence of too serious condensation cannot be avoided 100%. Since condensation is an objective physical phenomenon, there are usually two ways to avoid it:

- a) The water temperature of the water-cooling machine is higher than the dew point temperature, but it should meet the cooling requirements of the laser. Therefore, in the corresponding environment, the water temperature of the laser can only be set in the blue region of the dew-point comparison table, so this method has certain limitations.
- b) By changing the temperature and humidity of the working environment of the laser and reducing them, the water-cooling temperature of the laser can be relaxed and the water temperature can be far away from the dew-forming temperature.

2.6 Matters Need Attention

- a) Ensure reliable grounded before using the laser.
- b) Before supplying the power to the device, make sure that the correct voltage of the AC power source is used (380VAC). Failure to connect power source correctly will damage the device.

- c) When the laser is in running state, do not touch the laser machining head.
- d) Do not look directly at the output head. Make sure to wear laser protective glasses when operating the machine.
- e) Please inspect the output head carefully for dust or other contaminations. Use appropriate lens paper to clean it if necessary.
- f) The high temperature laser in summer is easy to produce dew and cause permanent damage. Please make sure that the water cooling machine stops at the same time when the laser stops.
- g) The freezing of cooling water inside the low-temperature laser in winter will cause permanent damage. Please ensure the continuous operation of the water-cooling machine under the shutdown state of the laser.
- h) Failure to follow the specified instructions may result in the loss of laser power, and such loss will not be covered by the warranty.

2.7 Specifications

Table 5 Properties of Products

Optical Parameters	
Model	RFL-A3000D
Nominal Output Power (W)	3000
Operation Modes	CW/Modulated
Polarization Orientation	Random
Output Power Tunability(%)	10~100
Emission Wavelength(nm)	915±10
Output Power Instability(%)	≤3
Modulation Frequency(Hz)	50~10k
Pilot Light Power(mW)	0.25~1
Output Cables Parameters	
Output Header Type	iHQB

Fiber Core Diameter(μm)	600/660
Minimum Bending Diameters	≥ 400
Half Angle of beam divergence (rad)	≤ 0.22
Delivery Cable Length(m)	20(Customizable)
Electrical Parameter	
Power Supply	AC 380V \pm 38, 50/60Hz, TN-S
Control Mode	RS-232/AD
Other Parameters	
Dimensions(W \times H \times D) (mm)	485 \times 133 \times 661
Weight(kg)	<80
Operating Ambient Temperature ($^{\circ}\text{C}$)	10~40
Humidity (%)	<70
Storage Temperature ($^{\circ}\text{C}$)	-10~60
Cooling Method	Water Cooling

3 Installation

3.1 Dimensions

Figure shows dimensions of products:

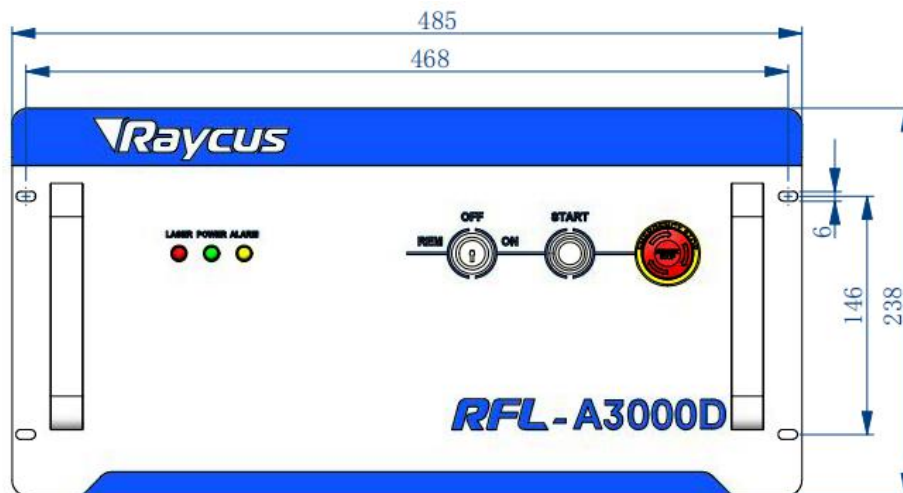

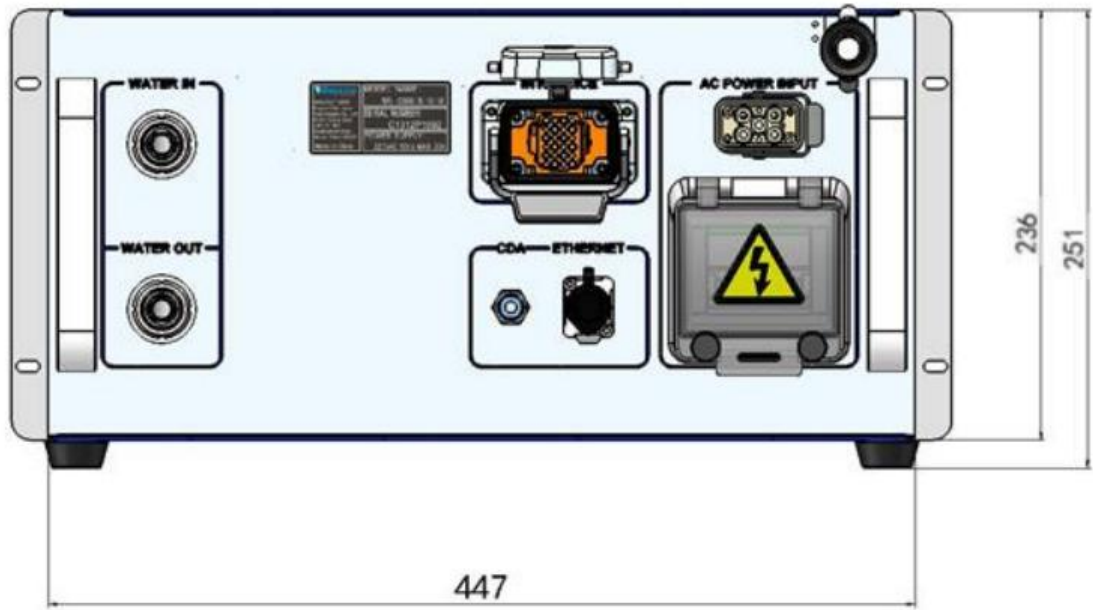

Figure 2 Front/Rear view of the laser(unit: mm)

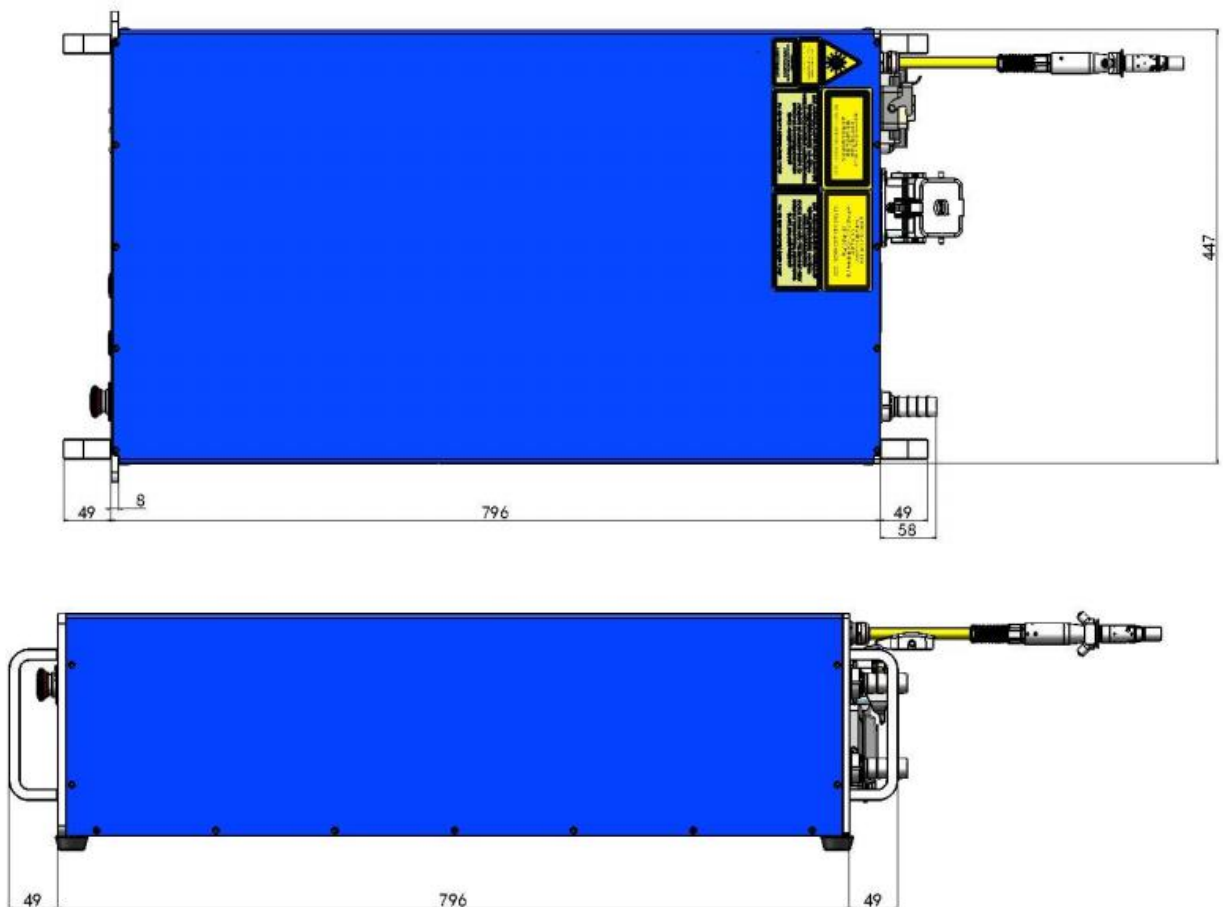

Figure 3 Top/Side view of the laser(unit: mm)

3.2 Output Head and Installation

Figure 4 shows iHQB Output Head:

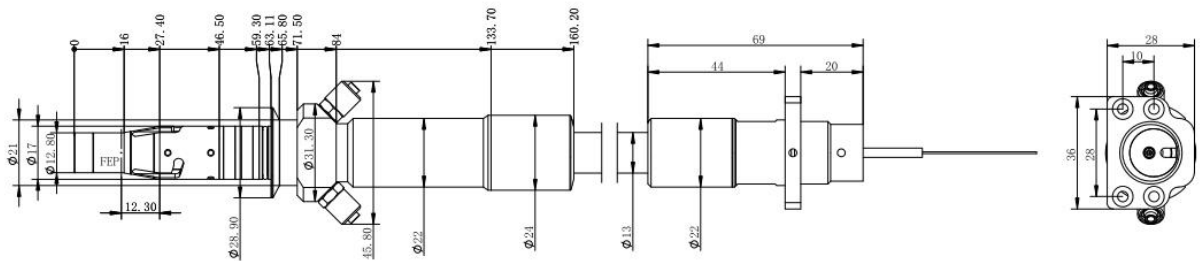

Figure 4 Dimensions of iHQB Output Head(unit: mm)

	<ul style="list-style-type: none"> ◆ Inspect the output lens before installing the output head to the processing head. wipe the output lens with absolute alcohol if it is unclean. ◆ When the output head is installed into the welding head, the welding head groove must be ensured to be connected to the two copper rings of the output head, otherwise an alarm will be generated. ◆ It is strictly prohibited to disassemble the output head by personnel not approved by Raycus, or the warranty is void.
--	--

3.3 Cooling Requirements

Table6 Cooling Requirements

Parameters	unit	RFL-A3000D
CoolingCapability Capability	kW	≥8 (3.2HP)
Minimum Flow	L/min	24
MaximumInput Pressure	Bar	7
Pagoda-Shape Connectors	mm	Connect Inner DiameterΦ19Water pipe
WaterChiller Categories	/	dual-temperature control

The water temperature setting of cooling system:

- a) summer (Ambient temperature is higher than 30°C) 25±0.5°C.
- b) winter (Ambient humidity temperature is lower than 30°C) 22±0.5°C.

Coolant requirements:

- a) The cooling water is pure water. It is recommended to use pure drinking water;
- b) In order to prevent mould growing that may lead to pipe blockage, we recommend to add alcohol about 10% of the total volume.

Other requirements for chiller:

- a) When starting the cooling system for the first time, check the entire water system and the joint for water leakage. The external water pipe must be installed and connected according to the inlet (IN) and outlet (OUT) by the laser. Otherwise, the laser may not work properly.
- b) If you will not use the laser for a long time, water must be emptied from the product, and then both the inlet and outlet must be blocked with the nuts we provide. Failure to do so may lead to permanent equipment damage.
- c) When the customer is emptying the cooling water of the laser water-cooling system, please use compressed gas with pressure less than 0.5mpa, otherwise it will cause irreparable damage to the chiller.

	<ul style="list-style-type: none"> ◆ Please set the water temperature in strictly accordance with the requirements above. Too low temperature may lead to condensation on the laser module and the output cable. This can cause serious damage to the equipment.
---	---

	<ul style="list-style-type: none"> ◆ Make sure that the water temperature reaches the set point and the cooling system is working well before you start the laser.(summer: 25±0.5°C; winter: 22±0.5°C)
---	---

3.4 Installation Procedure

- a) Place the product in an appropriate position, immobilize it if necessary.
- b) Check if the power supply has the correct voltage (AC 380±38V, 50/60Hz, TN-S), and the earth line is connected, make sure it is firm and reliable.
- c) Connect the power cable and control cable to the product when power supply is OFF.

- d) Insert the water pipes into the inlet and outlet;
- e) Check the output head and clean it if necessary. This procedure must be performed by Raycus personnel or person authorized by Raycus. Make sure the environment is clean, or the output cable may be contaminated.
- f) Prevent the delivery cable from treading, pinching or excessive bending during installation.
- g) In the installation of laser output cable and output head process, please make sure that the surrounding environment is clean, otherwise it may pollute the output head (do not use fan to avoid dust).

	<ul style="list-style-type: none">◆ All the cables can only be connected when power supply is OFF. Hotplug may damage the laser.
---	--

	<ul style="list-style-type: none">◆ The laser output optical cable should be kept as natural as possible and not be distorted.◆ The too small bending radius of the output fiber cable will damage the laser.
--	--

	<ul style="list-style-type: none">◆ Make sure the aperture and the cavity of the processing head is clean.◆ Prevent it from contamination; Or the aperture will be contaminated when capped.
---	---

4 Using the Product

4.1 Front/Rear Panel

Figure 5 shows the front panel of the product:

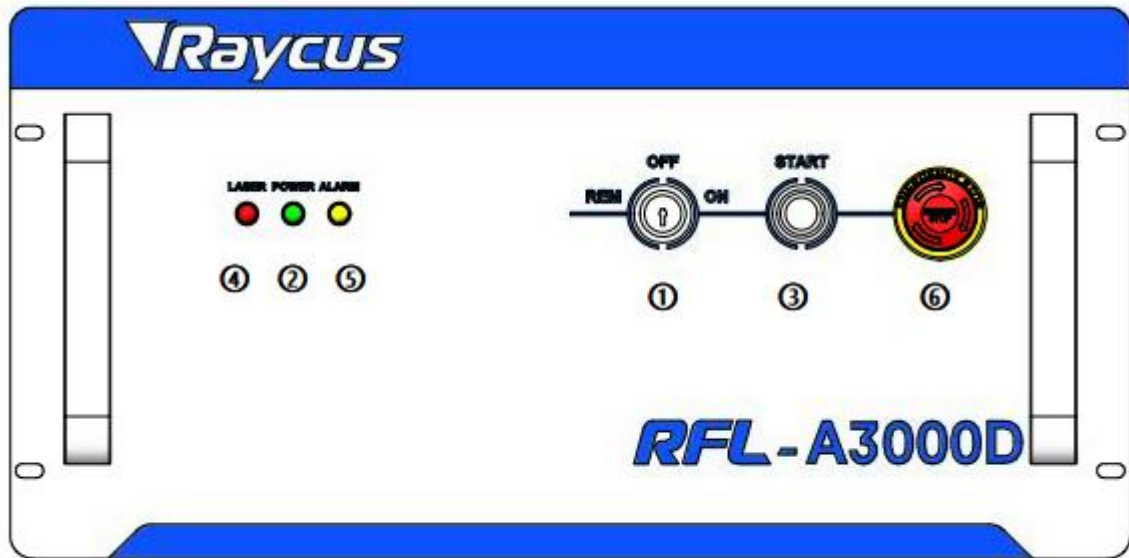

Figure 5 Front Panel

- 1. REM/OFF/ON:** Key switch, the power switch of the laser. Insert the key and turn the key clockwise to the 'ON' position or counterclockwise to 'REM' position will power on the laser. Then the laser will enter a control mode depending on your previous setup on the 'INTERFACE'. You can refer to 4.6 Control Mode for more details.
- 2. POWER:** Power Indicator, indicates that the power is switched on, when the green LED illuminates.
- 3. START:** The red indicator light is on, when the laser emit laser; Press the button the laser is in the state of waiting for light and the red light is off at the same time. Press this button again to pop up, and the laser will turn off the light to enable the red light to turn on at the same time.
- 4. LASER:** Laser emission indicator, RED, illuminates when laser emission is on.
- 5. ALARM:** Alarm indicator, YELLOW, indicates an error condition.
- 6. EMERGENCY STOP:** Pressing this button can shut down the laser, then Rotating this button to release. Use the key to power up the laser to get back.



Figure 6Rear Panel

Figure 6 shows the rear panel of the product:

1. **AC INPUT:**The socket for supply source input that can only be mated with the plug on the power cord we provided.The socket is equipped with protective cover and latch, Cover the power input interface with protective cover and secure it with latch when not using the product for a long time.

2. **POWER:** Air switch to control the on/off of alternating current.

3. **CTRL-INTERFACE:**This interface provides all control signals, including RS232 communication, laser switch control, laser remote control mode selection, analog control, modulation signal, Interlock interface and so on. The socket is equipped with protective cover and latch, Cover the power input socket with protective cover and secure it with latch when not using the product for a long time.

4. **WATER:** Water pipe joint, water inlet and outlet are used for cooling water inflow and outflow.

5. **ETHERNET:**Ethernet interface,providing remote control of laser and storage of alarm information.

6. **CDA:**Clean Dry air interface,access clean dry air to prevent laser condensation.

4.2 Power Connection

	<ul style="list-style-type: none"> ◆ Before connecting the product to AC supply source, you must check up that the AC supply you will apply is in accordance with the specifications provided. ◆ Failure to connect power source correctly will damage the device. Please carefully inspected before energize the laser to make sure the connections are correct
---	--

Table 7 Power Connection Instructions

MODEL	RFL-A3000D
POWER SUPPLY	380±10% V AC 50/60Hz
POWER LINE	
POWER CORD PIN	Four strands, Wire diameter 4mm ² , Mark L1, L2, L3 and PE
Description	L1, L2, L3->phase line PE->ground line

4.3 Interface Definitions

4.3.1 Control Interface Definitions:

Use the CTRL-INTERFACE interface to control. The specific interface is defined as follows:

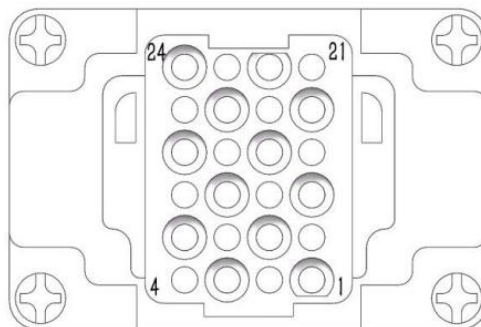



Figure 7 CTRL-INTERFACE Interface Diagram

Table 8 The Definition of 24-Pin Interface

Pin	Name	Label	Type	Level	Drive Capability	Response	Description
1	NULL		CLOSED CONTACT INPUT	5Vdc	<1A	<500ms	Active contact, unable to connect external voltage or ground connection
2	INTERLOCK1A	ITL_A					
3	INTERLOCK1B	ITL_B					
4	NULL						
5	RS232Tx	TX				120ms	Data transmit
6	RS232Rx	RX					Data receive
7	RS232Com	GND					RS-232 Response
8	REMOTE SWITCH	RPA	CLOSED CONTACT INPUT	24Vdc	<1A	<1s	In remote mode, power supply of internal Main Control Board is started
9		RPB					
10	NULL						
11							
12	CURRENT CONTROL ANALOG INPUT	0-10V	ANALOG INPUT	1-10Vdc	1mA	300us	Current setting analog input: 1-10VDC=10 - 100% current
13	POWER MONITORING ANALOG OUTPUT	AOUT	ANALOG OUTPUT	0-5.0Vdc	10mA	30μs	Analog output 0-5.0VDC
14	SYSTEM PUBLIC GROUND	AGND	RESPONSE				Public ground of 12、13 Pin
15	MODULATION+	MOD+	DIGITAL INPUT	24Vdc	6mA	20μs	24VDC Input
16	MODULATION-	MOD-	RESPONSE				Response of 15 Pin
17	EXTVCC	EVCC	DIGITAL INPUT	24Vdc	100mA	1ms	External function power supply pin

18	LASER ENABLE	LAS-C	DIGITAL INPUT	24Vdc	6mA	1ms	Laser enable, used for opening the gate in external mode
19	READY	RDY	DIGITAL OUTPUT	24Vdc	100mA	120ms	High level = Laser ready
20	RESPONSE (QUARANTINE)	EGND	RESPONSE				Response of 17 、 18 、 19 、 21 、 22 Pin
21	AD/RS	AD/RS	DIGITAL INPUT	24Vdc	6mA	120ms	In the state of REM, the control board is powered on to a high level and enters the external AD mode
22	SYSTEM FAILURE (ERROR)	S-ERR	DIGITAL OUTPUT	24Vdc	100mA	120ms	High level = system alarm
23	NULL						
24	NULL						

	<p>◆ Please check the level of control signal to ensure it meets the requirements. Both fluctuated and overloaded voltage may damage the laser</p>
---	--

4.3.2 TCP/IP Interface Configuration

The default IP address of this product is 192.168.0.10, only supports UDP communication. The laser listens for connection on port is 8098, and the command must be sent in a single data string.

Table 9 The Pins Definition of Ethernet Interface

PIN	FUNCTION	DESCRIPTION
1	TX+	TRANSMIT+
2	TX-	TRANSMIT-
3	RX+	TRANSMIT+
4	N/C	NONE

5	N/C	NONE
6	RX-	RECEIVE-
7	N/C	NONE
8	N/C	NONE

For better communication stability, recommend to use this interface first.

The steps of Ethernet connection:

- a) Open the Raycus PC software, click "Session → RS232 (or Ethernet)" to make the PC communicate with the laser, and then click "Tool → Laser IP Set" to enter the laser IP address setting;
- b) The default password is "1122334455667788". After the verification is passed, reador set the new laser IP address.
- c) If you use the Raycus PC software to control the laser, you need to find the folder where the PC software is located, open the laser configuration file "config.xml", and write the newly laser IP address. If you do not use Raycus software, please go to the step 4;
- d) Configure TCP/IP, select "Use the following IP address", manually assign an IP address, and the IP address of the PC must be in the same network segment as the laser IP address, and assign a subnet mask address. The default is 255.255.255.0, click the "OK" button to confirm the settings and exit.

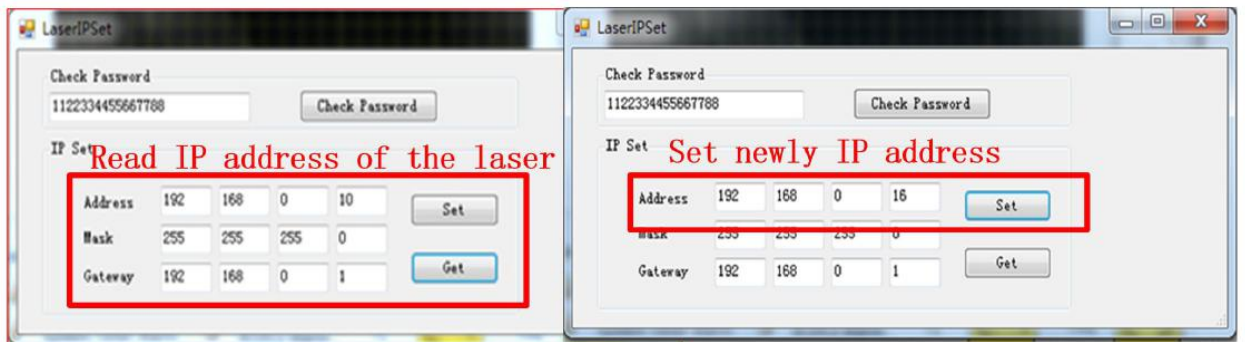

If you do not use Raycus software, please go to the step 4

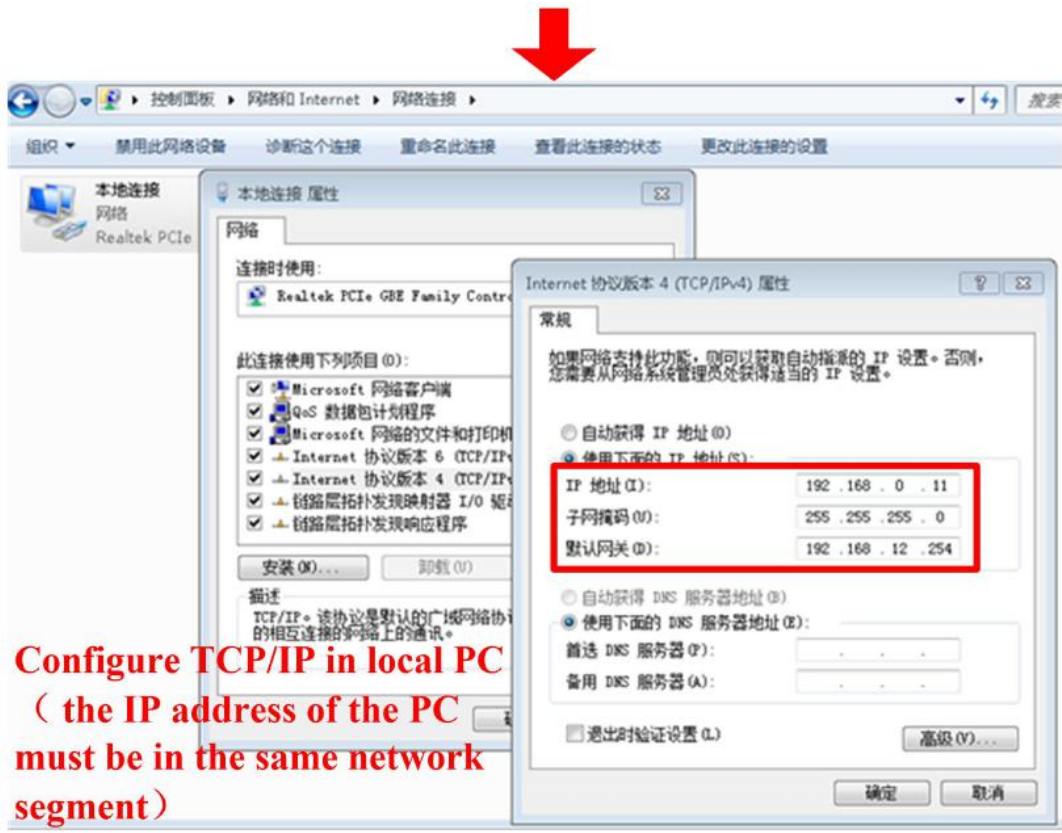
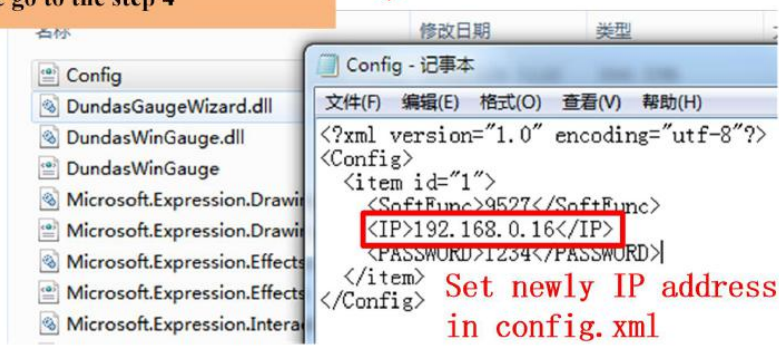

Configure TCP/IP in local PC
(the IP address of the PC must be in the same network segment)

Figure 8 The Steps of Ethernet Connection

4.4 Installation Sequence

- 1) Carefully remove the laser and move the laser to the installation position;
- 2) Remove the protective cap of the output head, and check whether there is dust in the lens of the output end with strong light. If so, please clean it before using it, and then cover the protective cap of the output head;
- 3) Install the output optical cable on the processing equipment according to the actual situation (at the same time install the cooling water pipe of the output head), pay attention to the arrangement of the output light slow, and protect the output head. Remove the protective cap, and confirm again whether the output end lens is clean, and then install the output head;
- 4) Connect the laser cooling water
- 5) Connect the control circuit and power supply according to the pull mode.

4.5 Process for Starting the Laser

Make sure the air switch is off and the EMERGENCY STOP button on the laser's front panel is pressed. All electrical connections must be completed before the laser is powered on;

- 1) Ensure that pin 2 and pin 3 of the 24 pins are closed;
- 2) Turn on the chiller and check whether the water pipe leaks. If not, turn off the chiller and wait for the laser to turn on;
- 3) Close the air switch on the rear panel and release the emergency stop switch on the front panel of the machine;
- 4) Turn on the chiller;

4.6 Control Mode Selection

Control mode wiring diagram

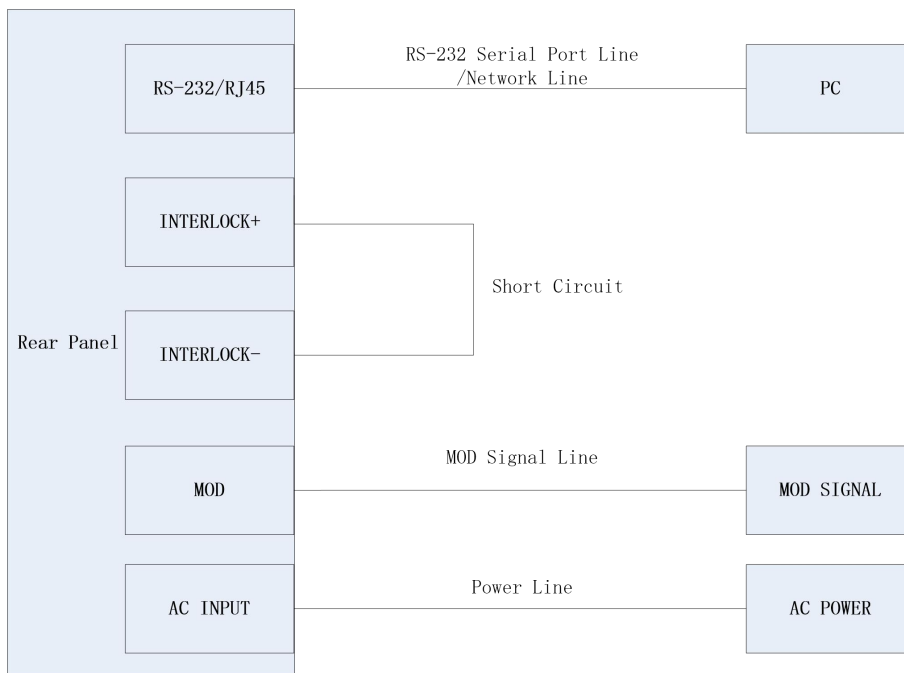

Figure 9 Wiring diagram in RS-232 mode

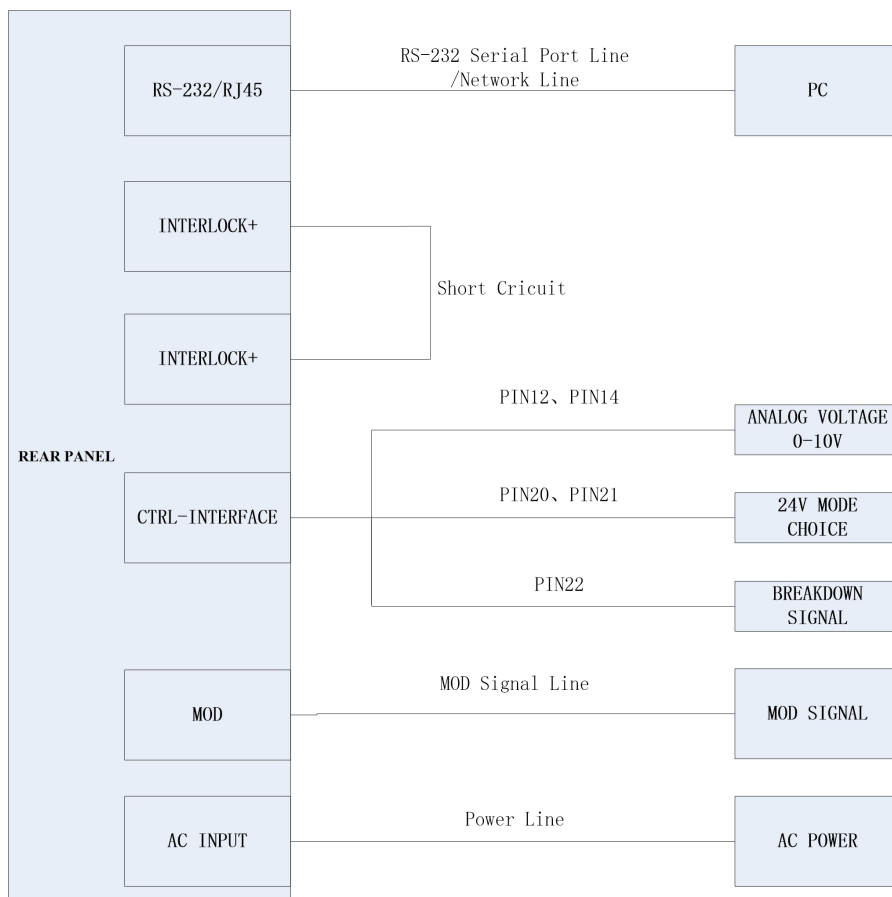

Figure 10 Wiring diagram in AD mode

Single machine mode (internal control mode)

- 5) Rotate the key switch clockwise to the "ON "position, and the "Power" indicator ON the front panel will light up;
- 6) Wait for 10S, the internal main control board circuit initialization is completed;
- 7) Set the power of the laser (the power of the laser is set by serial port or Ethernet);
- 8) Press the "Laser" button on the front panel of the machine to enable light output;
- 9) The serial port or Ethernet interface sends the open light command output laser, and sends the off light switch command to turn off the laser. The laser See "4.8· Closing operation Sequence" for the closing operation process.

External control mode

Modulation mode: when the duty cycle of the internal pulse of the laser is set to 100%, the laser works in the external modulation mode, and the laser is switched on and off by the user from the outside. MOD Interface provides "modulated" signal control.

- 5) Rotate the key switch counterclockwise to the "REM" position (or the key switch to. Short connect 24 stitches 2 and 3 Pin), the front panel "Power "indicator light is on;
- 6) Wait 10S, the internal main control board circuit initialization is completed;
- 7) Set the power of the laser (when AD mode is enabled, the power of the laser is set by 0-10V analog quantity, and AD· mode is off the laser power is set by serial port or Ethernet.
- 8) Give the light enabling signal to the laser in one of the following ways:
 - Press the "Laser" button on the front panel of the machine.
 - or 24 pin control interface PIN18 and PIN20 indirect 24v light output enable;
 - Or serial port or Ethernet interface to turn on the light switch command one by one to enable the light;
- 9) Laser on and off by the external MOD interface provided by the "modulation" signal control; See "4.8 Shutdown Operation Sequence" for the laser shutdown operation process.

AD mode

24 Pin control interface PIN20-21 Indirect 24V, the laser enters the external AD mode, the power of the laser is controlled by the voltage between pin12-24 of the 24pin control interface (1V-10% power, 10V-100% power).

24 pin control interface PIN20-21 indirect OV or suspended, the power of the laser is set by the serial port or Ethernet.

Control sequence diagram

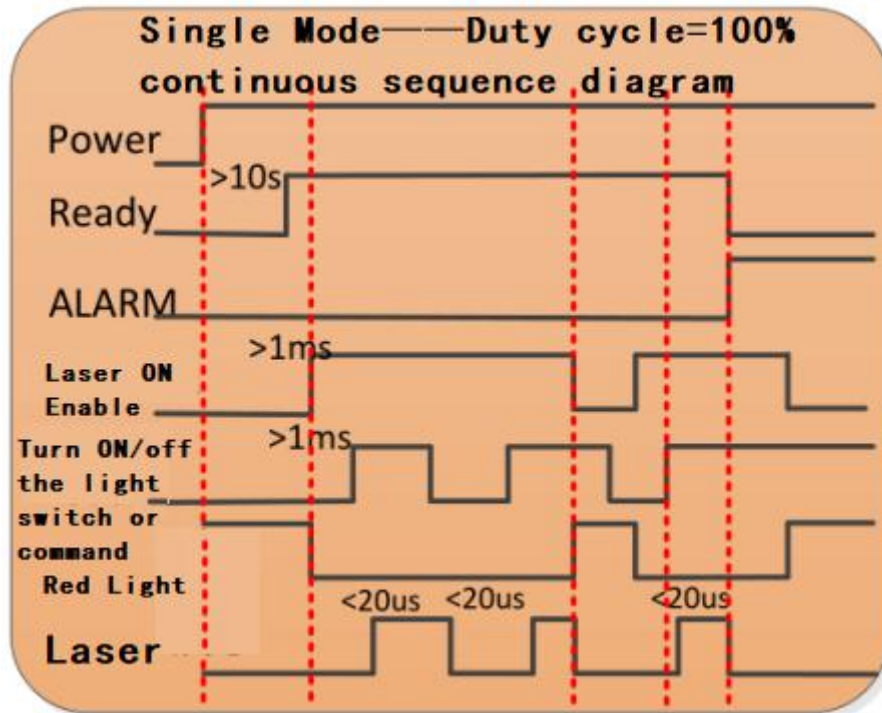

Figure 11 Single Mode - continuous control diagram

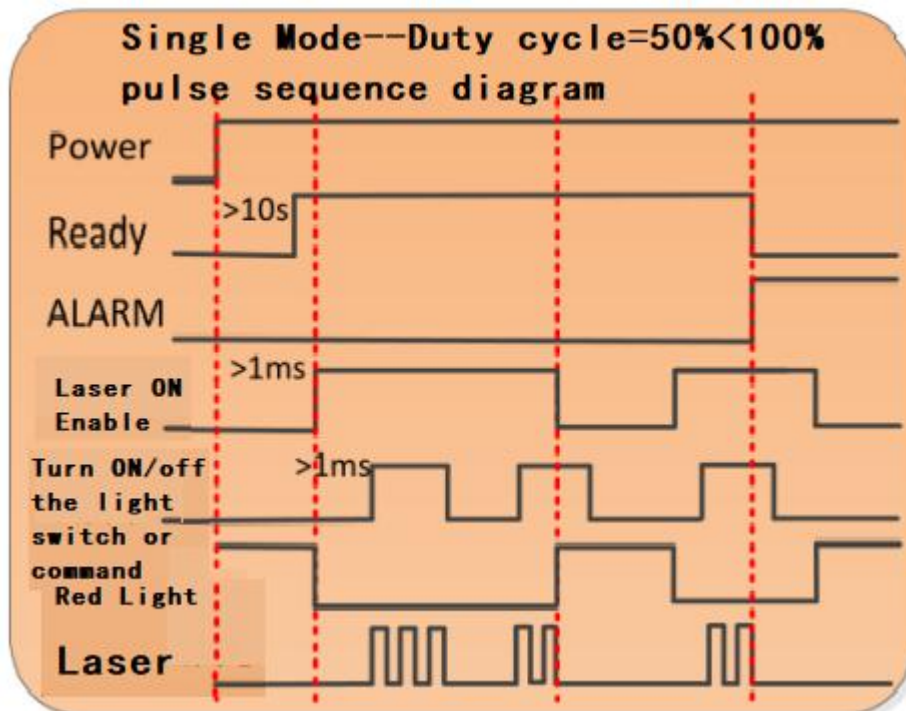

Figure 12 Single Mode - pulse sequence diagram

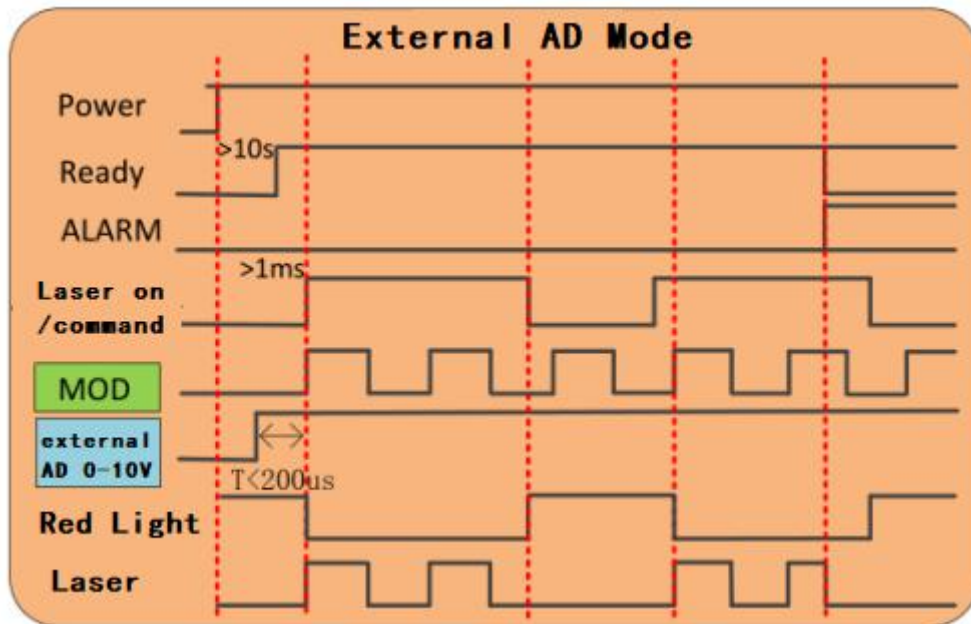

Figure 13 External AD mode control sequence diagram

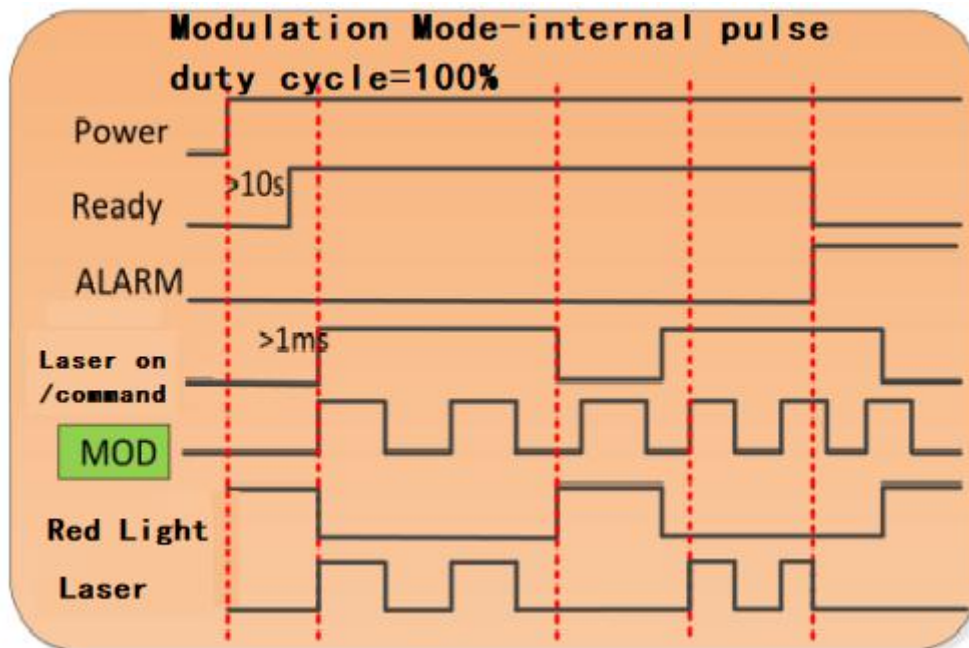

Figure 14 Modulation mode control sequence diagram

4.7 Red light control

Turn the key switch to "REM" or "ON" position, the laser is powered ON, "POWER" edge color indicator light is lit, the laser red light output. Press the LASER key or use the serial port control software to turn on the smooth, and the red light indicates that the smooth is off. Press

the LASER key or use the serial port control software to turn off the light surge, and the red light indicates the output.



◆ Laser and red indication can not be tested at the same time. If there is no red light output in the process of use, check whether the laser signal can be closed.

4.8 Shutdown operation sequence

- a) Please turn off the laser in sequence :
- b) Turn off light output;
- c) Turn OFF the key switch (turn the key to -OFF) and press the "Laser" button;
- d) Turn off the chiller;
- e) If the laser does not have air conditioning, please ignore this step; If the laser is equipped with an air conditioner, wait for the air conditioner to continue working for 10 minutes;
- f) Disconnect the air switch;
- g) Cover the output head protection cap.

5 Alarms and Solutions

5.1 Alarms Display

Connect computer and establish communication with the client software, all alarm states of the laser can be displayed on the client software homepage. When inner temperature, output power, Power supply, moisture condensation is abnormal, the laser will send out alarm information.

If any alarm occurs (except for Interlock alarm) when the laser is running, the homepage will display the alarm that occurs, and the ALARM light (yellow) on the front panel of the laser will light up, the laser will stop emitting and lock.

When the Interlock is abnormal, the output of Ready signal is low, and the Interlock state is abnormal in the software homepage, but the laser is not locked, and the ALARM light (yellow) is not lit. The output of Ready signal is on high level when the Interlock is normal.

5.2 Alarm Solutions

The instructions and solutions of alarms are as follows:

Table 10 Instructions and Solutions for Alarms of Laser

Alarm name	Alarm instructions and solutions
System Timer Alarm	<p>Instruction: The internal clock of laser is abnormal.</p> <p>Solution: If it displays this alarm, please contact Raycus.</p>
Laser On Button Alarm	<p>Instruction: This alarm occurs, Pin15 and Pin 16 in the ‘CTRL-INTERFACE’ interface has been connected before the laser is powered on.</p> <p>Solution: Please power off and disconnect Pin15 and Pin 16 in the ‘CTRL-INTERFACE’ interface the “LASER” button. Repower and check if the alarm is resolve. If this alarm continues to occur, please contact Raycus.</p>
InterLock Alarm	<p>Instruction: Occurs when the InterLock is disconnected.</p> <p>Solution: Short the InterLock pins and restart the laser to try. If this error continues to occur, please contact Raycus.</p>
Current Driver Alarm	<p>Instruction: Current Driver Alarm, this error occurs when the constant current driver board inside the laser is abnormal.</p> <p>Solution: Restart the laser, If this error continues to occur, please contact Raycus.</p>
Laser Power Alarm	<p>Instruction: The laser will get this error when it does not emit with correct settings. Power error occurs only when the laser is emitting.</p> <p>Solution: Restart the laser, if this error continues to occur, please contact Raycus.</p>
ACDC1 Alarm	<p>Instruction: ACDC1 Error, failure of the laser power supply or sudden power failure of the power supply system may cause an alarm.</p> <p>Solution: Check if the input AC voltage is normal. Restart the laser, if this error continues to occur, please contact Raycus.</p>
T1/T4 Alarm	<p>Instruction: Low temperature/high temperature alarm of the laser. The sensor in the laser detects an abnormal temperature inside the laser. A high-temperature / low-temperature error occurs when the temperature at the monitoring point exceeds the set upper / lower limit.</p> <p>Solution: High temperature alarm, please check if the water-cooling system is normally working, the water temperature is set correctly, and the water connection is correct. When the water cooling system works normally and the water temperature drops below 30°C, restart the laser. If the alarm continues, please contact Raycus. Low temperature alarm, please check if the actual water temperature of the water is too low. In addition, a low ambient temperature may also cause a low temperature alarm when the laser is cold. Please wait until the water temperature of the water rises above 10°C. If the alarm continues, please contact Raycus.</p>
Hum Alarm	<p>Instruction: The laser detects that the current water-cooled plate temperature is lower than the internal dew point temperature, There is a risk of condensation in the</p>

	<p>equipment internal.</p> <p>Solution: Stop using the laser immediately, Waiting for ambient temperature to come back to normal, Repower the laser. If the alarm continues to occur, please contact Raycus.</p>
--	--

In addition to the above, if there are any questions or errors in using of the laser, you can contact Raycus to get help.

6 Warranty, Return and Maintenance

6.1 General Warranty

Raycus warrants that all Raycus fiber laser products are conformed to applicable products specifications under normal use and are free from defects in materials and workmanship. The warranties start on the date of shipment from Raycus for a period of time as set forth in the applicable purchase contracts or product specifications.

Raycus has the right to choose to repair or replace any product that proves to be defective in materials and workmanship selectively during the warranty period. Only products with particular defects are under warranty. Raycus reserves the right to issue a credit note for any defective products produced in normal conditions.

6.2 Limitations of Warranty

The warranty does not cover the maintenance or reimbursement of our product of which the problem results from tampering, disassembling, misuse, accident, modification, unsuitable physical or operating environment, improper maintenance, damages caused by those who are not from Raycus due to excessive use or not following the instructions. Customer has the responsibility to understand and follow this instruction to use the device. Any damage caused by fault operating is not warranted. Accessories and fiber connectors are excluded from this warranty.

According to the warranty, client should write to us within 31 days after the defect is discovered. This warranty does not involve any other party, including specified buyer, end-user or customer and any parts, equipment or other products produced by other companies.

	<p>◆ It is the customer's responsibility to understand and follow operating instructions in this User Guide and specifications prior to operation-failure to do so may void this warranty. Accessories and fiber connectors are not covered by this warranty.</p>
---	---

6.3 Service and Repair

- a) Do not open the device. There are no user serviceable parts, equipment or assemblies for user in this product. All service and maintenance shall be performed by qualified Raycus personnel.
- b) Please contact Raycus as soon as possible when problems under warranty about maintenance happened to the product.
- c) The product returned with permission should be placed in a suitable container.
- d) If any damage happened to the product, please notify the carrier in document immediately.

We reserve the right to make changes in design or constructions of any of our products at any time without incurring any obligation to make changes or install the same on units previously purchased.

All the items about warranty and service above provided by Raycus are for user's reference; formal contents about warranty and service