



# **Fiber Delivered Direct Diode Lasers User Guide**

**RFL-A1000D~2000D**

## TABLE OF CONTENTS

<b>1 Safety Information.....</b>	<b>3</b>
1.1 Symbols Used in This User Guide.....	3
1.2 Laser Classification.....	3
1.3 Safety Labels.....	4
1.4 Optical Safety.....	5
1.5 Electrical Safety.....	5
1.6 Other Safety Rules.....	6
<b>2 Product Description.....</b>	<b>6</b>
2.1 Features.....	6
2.2 Model Configuration.....	6
2.3 Package Contents.....	7
2.4 Unpacking and Inspection.....	7
2.5 Operation Environment.....	8
2.6 Specifications.....	9
2.7 Properties of Products.....	10
<b>3 Installation.....</b>	<b>11</b>
3.1 Dimensions.....	11
3.2 Output Head and Installation.....	13
3.3 Cooling Requirements.....	13
3.4 Installation Procedure.....	14
<b>4 Using the Product.....</b>	<b>15</b>
4.1 Front and Rear Panel.....	16
4.2 Power Connection.....	17
4.3 Interface Definitions.....	18
4.4 Work Patterns and Control Modes.....	26





4.5 Operating Process.....	26
4.6 Selection of Control Mode.....	26
4.7 Pilot Light to Control.....	34
4.8 Steps of Shutting Down.....	35
<b>5 Alarms and Solutions.....</b>	<b>35</b>
5.1 Alarms Display.....	35
5.2 Alarm Solutions.....	35
<b>6 Warranty, Return and Maintenance.....</b>	<b>37</b>
6.1 General Warranty.....	37
6.2 Limitations of Warranty.....	37
6.3 Service and Repair.....	37

## 1 Safety Information

Thank you for choosing Wuxi Raycus Fiber Delivered Direct Diode laser. This User Guide provides important safety, operation, warranty and other information. Please read it carefully before you use this product. In order to ensure safe operation and optimal performance of the product, please follow the warnings, cautions, operating procedures and other instructions accordingly.

### 1.1 Symbols Used in This User Guide

	◆ Refers to a potential hazard that may lead to personal injury or death.
---	---

	◆ Refers to a potential hazard that may lead to personal injury or product damage.
---	--

### 1.2 Laser Classification

According to the national standard GB 7247.1, clause 9, this type of laser is a class 4 laser instrument. The product emits laser radiation with a wavelength of 915nm or around 915nm, and the optical power radiated by the output head is greater than 1000W ~ 2000W, which, depending on product model. Direct or indirect exposure to such light intensity can cause damage to the eyes or skin. Although the radiation is invisible, the beam can still cause irreversible damage to the retina or cornea. Appropriate and certified laser safety glasses must be worn at all times when the laser is running.

	◆ Make sure to wear laser safety glasses during the operation of the product. Laser safety glasses have laser wavelength protection selectivity, so users are requested to choose laser safety glasses that are separate from the laser output of the product. When the laser is energized (regardless of whether it is in the light-emitting state), you cannot also directly watch the output head.
---	---

### 1.3 Safety

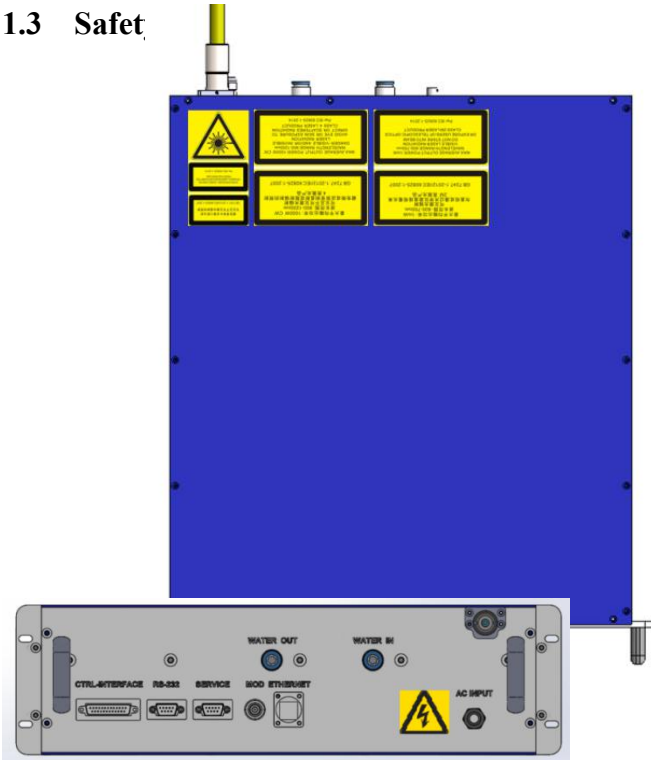



Figure1 Top View and Back View

Figure 1 shows the product safety labels and its location. These safety signs include: safety warnings, laser output head warnings, product nameplates, etc. The safety identification details are as follows:

Table1 Safety Identification

	<p>AVOID EXPOSURE—VISIBLE AND/OR INVISIBLE LASER RADIATION IS EMITTED FROM THIS APERTURE</p> <p>Per IEC 60825-1:2014</p>	<p>避免受到从本窗口射出的可见及不可见激光辐射的照射</p> <p>GB 7247.1-2012/IEC 60825-1:2007</p>
<p>a) Laser Radiation Hazard</p>	<p>b) Aperture Label</p>	<p>c) Aperture Label(CN)</p>
<p>MAX. AVERAGE OUTPUT POWER: 1000W CW WAVELENGTH RANGE: 900-1200nm DANGER—VISIBLE AND/OR INVISIBLE LASER RADIATION AVOID EYE OR SKIN EXPOSURE TO DIRECT OR SCATTERED RADIATION CLASS 4 LASER PRODUCT Per IEC 60825-1:2014</p>	<p>最大平均输出功率: 1000W CW 波长范围: 900-1200nm 可见及不可见激光辐射 避免眼或皮肤受到直射或散射辐射的照射 4类激光产品 GB 7247.1-2012/IEC 60825-1:2007</p>	<p>MAX. AVERAGE OUTPUT POWER: 1mW WAVELENGTH RANGE: 600-700nm VISIBLE LASER RADIATION DO NOT STARE INTO BEAM OR EXPOSE USERS OF TELESCOPIC OPTICS CLASS 2M LASER PRODUCT Per IEC 60825-1:2014</p>

d) Class 4 Laser Product(EN)	e) Class 4 Laser Product(CN)	f) Class 2M Laser ProductLabel for Guide Laser(EN)
		
g) Class 2M Laser ProductLabel for Guide Laser(CN)	h) Electrical Hazard Label	

## 1.4 Optical Safety

Any dust on the end of the collimator assembly can burn the lens and damage the laser.

	◆ If the output of the device is delivered through a lens with an anti-reflection coating, make sure that the lens is of good quality and clean.
--	--

## 1.5 Electrical Safety

- a) Make sure your product is grounded through the PE line of the AC power cord. The grounding must be firm and reliable.

	◆ Any interruption from the protective earth will electrify the enclosure, which may result in personal injury.
---	---

- b) Make sure that the correct voltage of the AC power source is used.

	◆ Failure to connect the correct voltage could damage the product.
---	--

There are no operator serviceable parts inside, so do not try to remove covers, or electrical shock may be caused, and warranty will be void.

## 1.6 Other Safety Rules

- a) Never look directly into the laser output port when power is supplied to the laser.
- b) Avoid using the laser in a dim or darkened environment.
- c) If this device is used in a manner not specified in this document, the protection provided by the device may be impaired and the warranty will be void.
- d) There are no operator serviceable parts inside, and all maintenance must be performed in Raycus or by qualified Raycus personnel. Do not try to remove covers, or electrical shock may be caused, and warranty will be void.

## 2 Product Description

### 2.1 Features

Compared with traditional lasers, Raycus CW fiber diode laser has higher efficiency electric-optical conversion, lower power consumption. The fiber laser is compact and ready to use. Because of its flexible form, it can be easily integrated with the system equipment.

Main Features:

Flexible output optical cable

High reliability and long service life

Maintenance free operation

High photoelectric conversion efficiency

Convenient control interface

High frequency modulation

Applications:

Laser-quenching, Laser-cladding

Metal sheet welding

Plastic welding

3D Printing

Laser research

### 2.2 Model Configuration

Fiber delivered direct diode lasers RFL-A1000D~2000D, and the model designation codes are illustrated in the following table:

Table 2 Model Names and Designation Codes

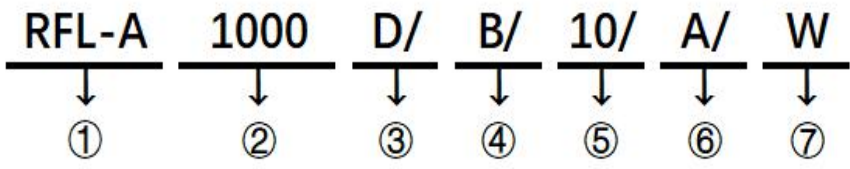
	
1	RFL-A series, Fiber Delivered Direct Diode Laser
2	Power in watts, there have 1000, 1500, 2000, which indicate respectively as 1000W, 1500W, 2000W
3	laser type, 'D' indicates direct output
4	Wavelength, there have B, C, D, E, which indicate respectively as 915nm, 976nm, 940nm, 808nm
5	Length of delivery cable in meter, including 5m and 10m, and other length can be customized
6	Interface type of delivery cable, 'A' indicates iHQB interface, 'B' indicates SMA905 interface, 'C' indicates D80 interface
7	Cooling method, 'W' indicates water cooling, 'T' indicates TEC air cooling, 'A' indicates air cooling

### 2.3 Package Contents

Please refer to the packing list accompanying the shipment to check actual items included.

### 2.4 Unpacking and Inspection

Raycus ensure that the laser do get adequate protection by special designed packaging material and box during the transit. Even so, In order to prevent the unpredictable component damage, users need to scrutinize the packing box is right before unpacking it whether or not cracking, abrasion, dampened and other phenomena. if there is any abnormality in the box body, Please contact us, we will correct it immediately.

On unwrapping the box, Please check that packing lists and physical goods are the same. If you have any questions, feel free to contact any of us at any time.

When taking the laser out of the box, Avoiding knock against and violent vibration on the laser. When taking optical fiber and output head, In particular, It is not possible to bend, twist and pull optical cable, At the same time should avoid output head suffering the blows and vibrations.

	<ul style="list-style-type: none"> <li>◆ The fiber optic cable and output head is precise opticinstrument, any vibration or impact to the output head, and twist orexcessive bend to the cable will damage the instrument.</li> </ul>
---	---

## 2.5 Operation Environment

The basic operation conditions are listed in the table below:

Table 3 Basic Operation Conditions for the Laser

requirements	parameters		
Laser (W)	1000	1500	2000
Supply Capacity(kW)	2.5	3.7	5.0
Installation	without significant shake, shock and vibration		
Ambient Temperature(°C)	10~40		
Relative Humidity(%)	<70		

It is recommended to install the laser in an air-conditioned environment so that the laser can operate under optimal conditions.

	<ul style="list-style-type: none"> <li>◆ Do not expose this product to high humidity (&gt;70%).</li> <li>◆ Do not expose this product to high temperature (&gt;40%).</li> <li>◆ Do not let this product work below the ambient dew point temperature.</li> </ul>
---	--

Table 4 The Constant Dew Point Table

AMBIENT DEW POINT						
Ambient Temperature(°C)	Maximum Relative Humidity					
	20%	30%	40%	50%	60%	70%
20	-3.5	2	6	9	12	14.5
25	0.5	6	10.5	14	16.5	19
30	4.6	10.5	15	18.5	21.5	24
35	8.5	15	19.5	23	26	28.5
40	13	20	24	27.5	31	33

The necessary moistureproof treatment has been done in the design of the laser, but the influence of too serious condensation cannot be avoided 100%. Since condensation is an objective physical phenomenon, there are usually two ways to avoid it:

- a) The water temperature of the water-cooling machine is higher than the dew point temperature, but it should meet the cooling requirements of the laser. Therefore, in the corresponding environment, the water temperature of the laser can only be set in the blue region of the dew-point comparison table, so this method has certain limitations.
- b) By changing the temperature and humidity of the working environment of the laser and reducing them, the water-cooling temperature of the laser can be relaxed and the water temperature can be far away from the dew-forming temperature.

## 2.6 Specifications

- a) Ensure reliable grounded before using the laser.
- b) Before supplying the power to the device, make sure that the correct voltage of the AC power source is used (220VAC or 380VAC). Failure to connect power source correctly will damage the device.
- c) When the laser is in running state, do not touch the laser machining head.
- d) Do not look directly at the output head. Make sure to wear laser protective glasses when operating the machine.

- e) Please inspect the output head carefully for dust or other contaminations. Use appropriate lens paper to clean it if necessary.
- f) The high temperature laser in summer is easy to produce dew and cause permanent damage. Please make sure that the water cooling machine stops at the same time when the laser stops.
- g) The freezing of cooling water inside the low-temperature laser in winter will cause permanent damage. Please ensure the continuous operation of the water-cooling machine under the shutdown state of the laser.
- h) Failure to follow the specified instructions may result in the loss of laser power, and such loss will not be covered by the warranty.

## 2.7 Properties of Products

Table 5 Properties of Products

Model	RFL-A1000D	RFL-A1500D	RFL-A2000D
Optical Parameters			
Nominal Output Power (W)	1000	1500	2000
Operation Modes	CW/Modulated		
Polarization State	Random		
Output Power Tunability(%)	10~100		
Emission Wavelength(nm)	915±10		
Output Power Instability(%)	<3		
Modulation Frequency(Hz)	50~10k		
Red Guide Laser Power(mW)	0.25~1		
Output Cable Parameters			
Output header type	iHQB		
Fiber Core Diameter(μm)	300	400	400/600
The minimum bending radius of the output fiber cable(μm)	≥200	≥300	≥300/400

Half Angle of beam divergence (rad)	≤0.22		
Delivery Cable Length(m)	5 (Length customizable)	10 (Length customizable)	
Electrical Parameters			
Power Supply	single phase 220VAC±10% 50/60Hz	three phase 380VAC±10% 50/60Hz	
Control Mode	RS-232/AD		
Other Parameters			
Dimensions(W×H×D) (mm)	485×133×584	485×133×661	
Weight(kg)	<36	<38	<40
Operating Ambient Temperature (°C)	10~40		
Humidity (%)	<70		
Storage Temperature (°C)	-10~60		
Cooling Method	Water Cooling		

### 3 Installation

#### 3.1 Dimensions

Dimensions of RFL-A1000D:

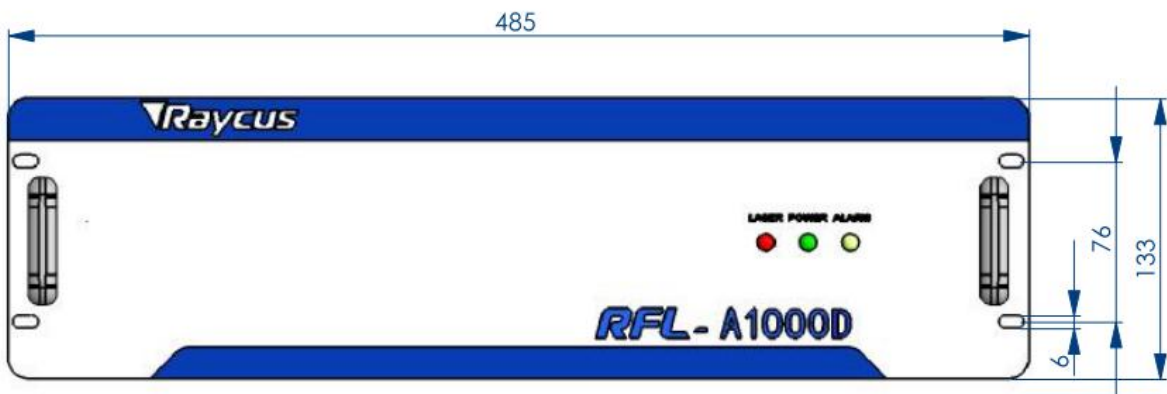

Figure2Front Panel View(unit: mm)

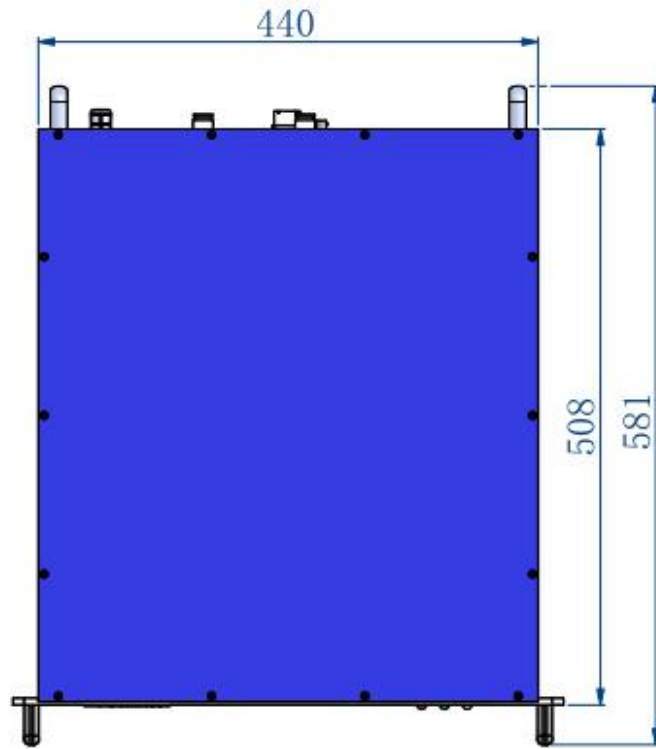

Figure 3-1 Top View of 1000w Laser (unit: mm)

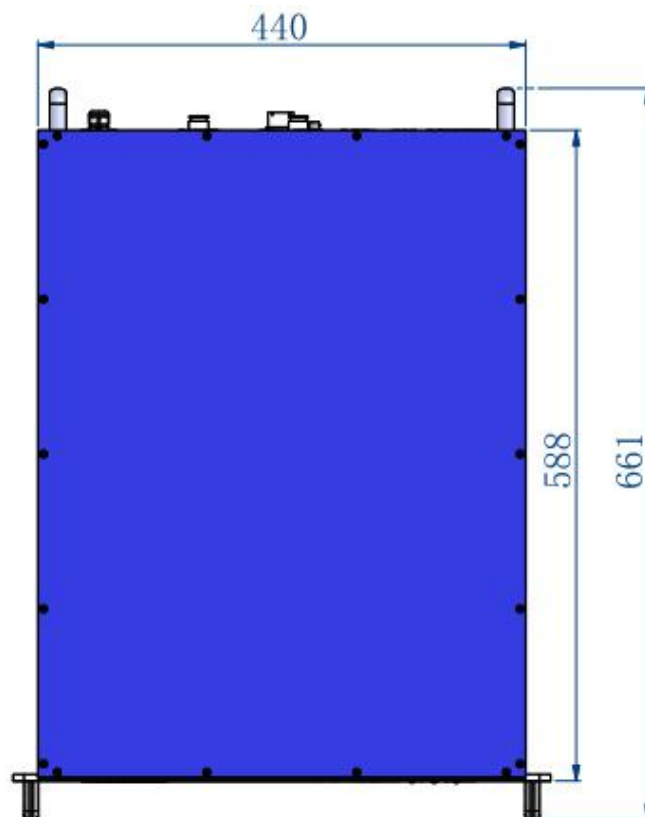

Figure 3-2 Top View of 1500w Laser and 2000w Laser(unit: mm)

### 3.2 Output Head and Installation

Figure 4 shows iHQB Output Head:

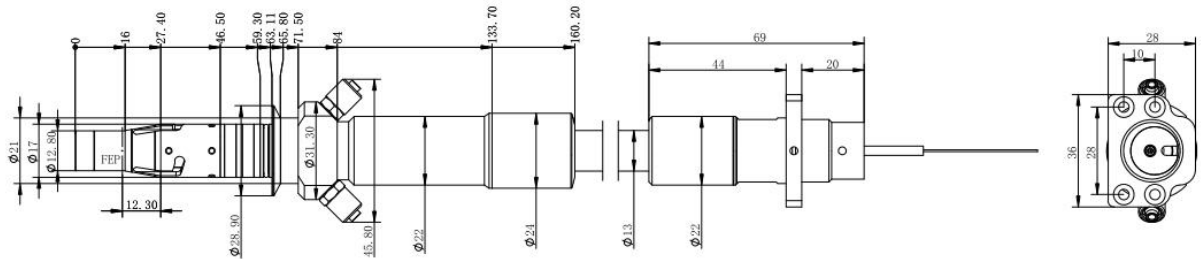

Figure 4 Dimensions of iHQB Output Head(unit: mm)

	<ul style="list-style-type: none"> <li>◆ Inspect the output lens before installing the output head to the processing head. wipe the output lens with absolute alcohol if it is unclean.</li> <li>◆ When the output head is installed into the welding head, the welding head groove must be ensured to be connected to the two copper rings of the output head, otherwise an alarm will be generated.</li> <li>◆ It is strictly prohibited to disassemble the output head by personnel not approved by Raycus, or the warranty is void.</li> </ul>
--	--

### 3.3 Cooling Requirements

Table6 Cooling Requirements

Parameters	unit	RFL-A1000D	RFL-A1500D	RFL-A2000D
Cooling Capability	W	≥3000 (1.2HP)	≥4000 (1.6HP)	
Minimum Flow	L/min	8	10	
Maximum Pressure	Bar	7		
Pipe Outside Diameter	mm	connector which could be plugged fast and straight-through (OD Φ10, PU)		
Water Chiller Categories	/	dual-temperature control		

a) The water temperature setting of cooling system:

- 1) summer (Ambient temperature is higher than 30°C)  $25 \pm 0.5^{\circ}\text{C}$ ;
  - 2) winter (Ambient humidity temperature is lower than 30°C)  $22 \pm 0.5^{\circ}\text{C}$ 。
- b) Coolant requirements:
- 1) The cooling water is pure water. It is recommended to use pure drinking water;
  - 2) In order to prevent mould growing that may lead to pipe blockage, we recommend to add alcohol about 10% of the total volume.
- c) Other requirements for chiller:
- 1) When starting the cooling system for the first time, check the entire water system and the joint for water leakage. The external water pipe must be installed and connected according to the inlet (IN) and outlet (OUT) by the laser. Otherwise, the laser may not work properly.
  - 2) If you will not use the laser for a long time, water must be emptied from the product, and then both the inlet and outlet must be blocked with the nuts we provide. Failure to do so may lead to permanent equipment damage.
  - 3) When the customer is emptying the cooling water of the laser water-cooling system, please use compressed gas with pressure less than 0.5mpa, otherwise it will cause irreparable damage to the chiller.

	◆ Please set the water temperature in strictly accordance with the requirements above. Too low temperature may lead to condensation on the laser module and the output cable. This can cause serious damage to the equipment.
---	---

	◆ Make sure that the water temperature reaches the set point and the cooling system is working well before you start the laser.(summer: $25 \pm 0.5^{\circ}\text{C}$ ) ; winter: $25 \pm 0.5^{\circ}\text{C}$ )
---	---

### 3.4 Installation Procedure

- a) Place the product in an appropriate position, immobilize it if necessary.
- b) Check if the power supply has the correct voltage (See Table 5 for the laser model and corresponding input voltage ), and the earth line is connected, make sure it is firm and reliable;

- c) Connect the power cable and control cable to the product when power supply is OFF;
- d) Insert the water pipes into the inlet and outlet;
- e) Check the output head and clean it if necessary. This procedure must be performed by Raycus personnel or person authorized by Raycus. Make sure the environment is clean, or the output cable may be contaminated.
- f) Prevent the delivery cable from treading, pinching or excessive bending during installation.
- g) In the installation of laser output cable and output head process, please make sure that the surrounding environment is clean, otherwise it may pollute the output head (do not use fans, which actually may bring more dust).

	<ul style="list-style-type: none"><li>◆ All the cables can only be connected when power supply is OFF. Charged install control line may damage the laser.</li></ul>
---	---

	<ul style="list-style-type: none"><li>◆ The laser output optical cable should be kept as natural as possible and not be distorted.</li><li>◆ The too small bending radius of the output fiber cable will damage the laser.</li></ul>
---	--

	<ul style="list-style-type: none"><li>◆ In the process of installation and disassembly, please pay attention to gently hold the laser output head, do not be subjected to vibration and collision.</li></ul>
---	--

	<ul style="list-style-type: none"><li>◆ Make sure the aperture and the cavity of the processing head is clean.</li><li>◆ Prevent it from contamination; Or the aperture will be contaminated when capped.</li></ul>
---	---

#### 4 Using the Product

	<ul style="list-style-type: none"> <li>◆ Raycus CW fiber laser has stopped using theHyperTerminal, so the HyperTerminal will notworkwhen thelaser is powered on. Please clip the address below to downloadthe latest PC software and the relevant manual.</li> <li>◆ <a href="http://www.raycuslaser.com/index.php/index-show-tid-53.html">http://www.raycuslaser.com/index.php/index-show-tid-53.html</a></li> </ul>
---	---

#### 4.1 Front and Rear Panel

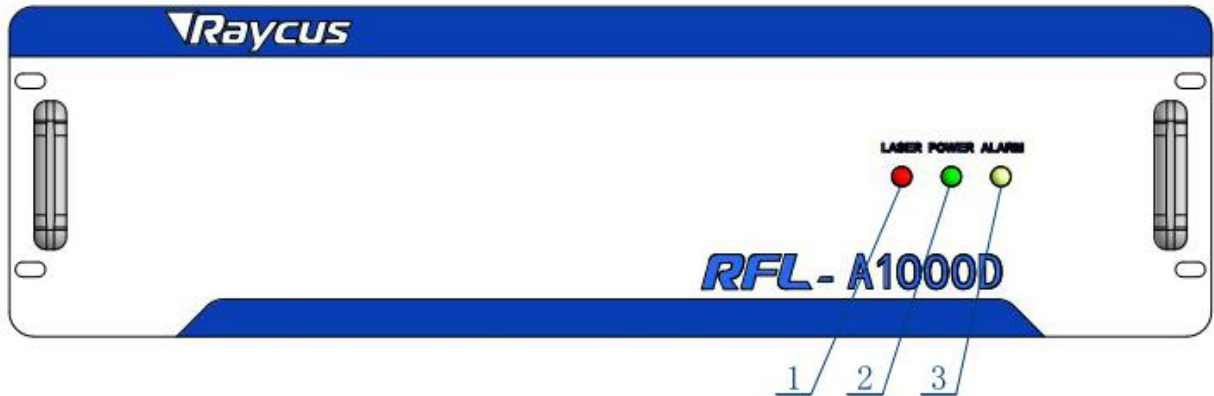

Figure 5 Front View

- ① LASER: Laser emission indicator, red led illuminates when laser emission is on; red LED extinguish indicates laser do not receive enable signal and red light is on
- ② POWER: Power Indicator, indicates that the power is switched on, when the green LED illumines.
- ③ ALARM: Alarm indicator, YELLOW, indicates an error condition.

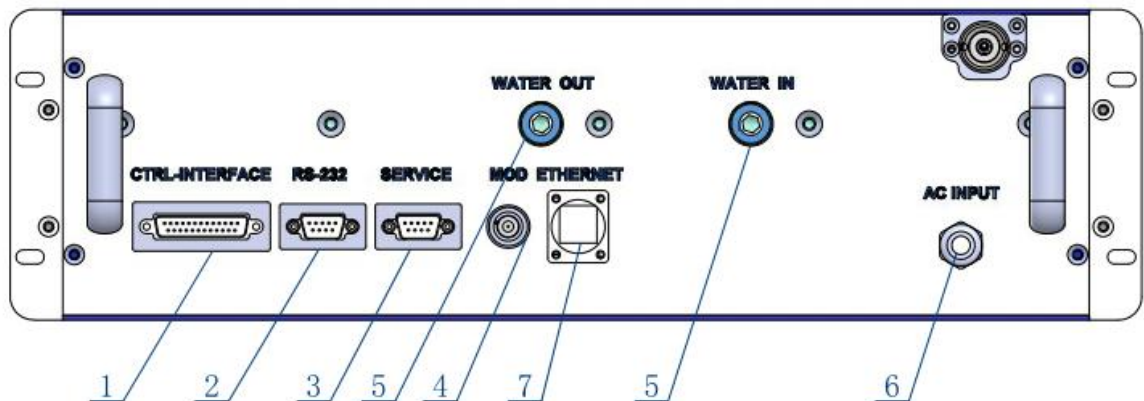



Figure 6Rear View

- ① CTRL-INTERFACE: Control interface, this interface is a male DB25 connector and it's multi-functional. The end users can set the control mode and input analog control signal with the interface, as well as get the fault signal from it.
- ② RS-232: RS-232 serial port, Provide remote control and alarm information storage for the laser.
- ③ SERVICE: The laser switch and security interlocking interface
- ④ MOD: Modulation input, Bayonet Nut Connector can apply to switch to disable or enable the laser. The control signal should be able to apply current over 10mA, and the voltage should be 24V.
- ⑤ WATER IN/OUT: Water pipe connectors, the inlet and outlet for cooling water to flow in and return
- ⑥ AC INPUT: 1000W and 1500W laser match 220VAC, 2000W laser match 380VAC.
- ⑦ ETHERNET: Ethernet interface. Provide remote control and alarm information for the laser.

## 4.2 Power Connection

	◆ Before connecting the product to AC supply source, you must check up that the AC supply you will apply is in accordance with the specifications provided.
---	---

One end of the power cord is a plug, insert it into the socket 'AC INPUT' on the rear panel. 1000W and 1500W lasers' power line consist of three lines, L, N and PE, Connected to the 220VAC. 2000W lasers' power line is made up of four lines, L1, L2, L3 and PE, Connected to the 380VAC.

Table 7 Power Connection Instructions

1000W/1500W	2000W	Definition
L	L1、L2、L3	Phase Line
N	N	Neutral
PE	PE	Protective Earth

### 4.3 Interface Definitions

#### 4.3.1 SERVICE Security Interface

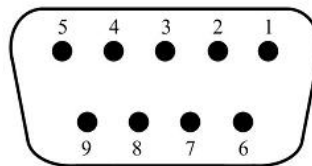

Figure 7 SERVICE Security Interface

Each pin is defined as shown in Table 8 below.

Table 8 SERVICE definition

PIN	Name	Function	Remark
1	PowerA	Remote switch, Passive contact, Can't be connected to external voltage or ground.	Short-circuit the pin 1 and 2 can power up the laser
2	PowerB		
6	INTERLOCK+	Passive contact, Can't be connected to external voltage or ground.	Short-circuit the pin 6 and 7 before emitting laser
7	INTERLOCK-		



- ◆ The interlock cannot be connected to active signal, or error will be caused, or even the product may be damaged.

### 4.3.2 Modulation Input

The 24V modulation signal should be applied to the connector as in Figure 8.

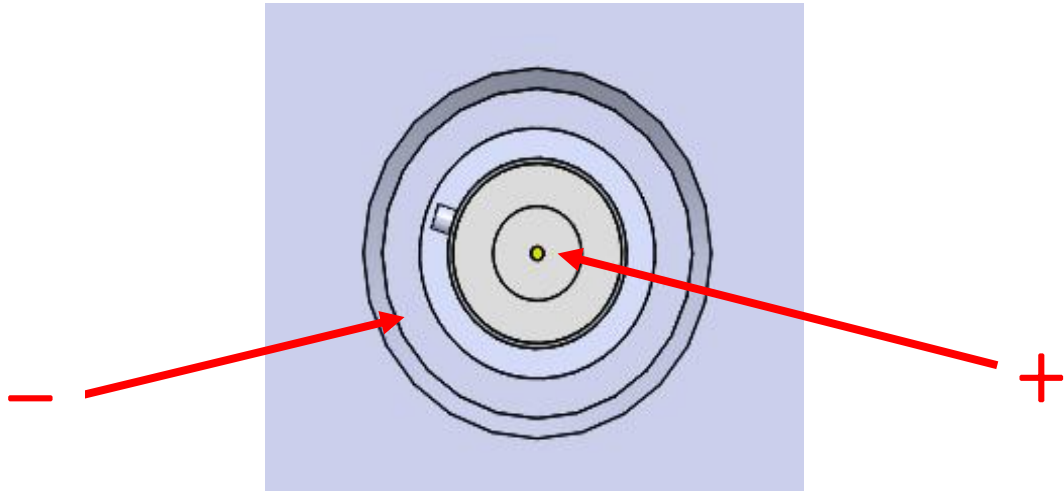

Figure 8 Modulation Input

Raycus provide MOD Cable, as shown in figure 9.



Figure 9MOD Cable-The Cable for Modulation Signal

	<ul style="list-style-type: none"><li>◆ The modulation signal cable core is positive (24V) and the external metal mesh is negative (GND). Before the modulated signal is connected to the laser, please check the level.</li></ul>
--	--

MOD definition is shown in table 9.

Table 9 MOD definition

Name	OUT/IN	Function	voltage	current
MOD	Input	External modulation signal	24V	10mA or above

The internal circuit of the modulation signal is shown in figure 10.

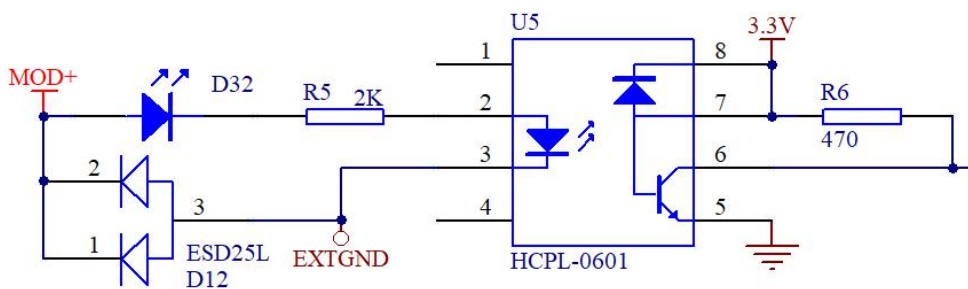

Figure 10 The Internal Circuit of The Modulation Signal

### 4.3.3 Control Interface

The pin number of 'CTRL-INTERFACE' is shown in figure 11

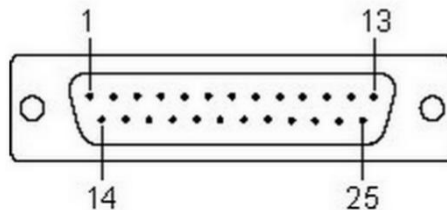

Figure 11 DB25 Control Interface

The definitions of the control interface are as follows:

Table 10 Control Interface Definitions

PIN	Name	Functions			Voltage	Current
6	LASER_EN	Input	Enable signal	Enable	24V	>8mA
				Disable	0V	/
7	AD_EN	Output	External AD model enable	Enable	24V	>8mA
				Disable	0V	/
8	Laser Ready	Output	Ready signal	YES	24V	<100mA
				NO	0V	/
9	EX_GND	/	Reference6,7,8,20,24GND	/	0V	/
15	LASER_EN_ON	/	Short-circuit the pin 15 and 16 to enable laser, disconnect these to shut down laser.	/	/	/
16	LASER_EN_VCC	/		/	/	/
17	REM_ON	/	Short-circuit the pin 17 and 18 to enable REM pattern, disconnect these to enable ON pattern	/	/	/
18	REM_ON_GND	/		/	/	/
20	EX_VCC	Input	24V (power for PIN8 and PIN24)	/	24V	<500mA
22	Analog	Input	Analog Voltage Signal	/	0V~10V	>10mA
23	Laser Power	Output	Power indication	/	0V~3.8V	<10mA
24	Alarm	Output	Fault Signal	Fault	24V	<100mA
				normal	0V	/
25	AGND	/	GND of PIN22, PIN23	0V		/
other	NC	/	None	/		/

	<ul style="list-style-type: none"> <li>◆ Please check the control voltage level and ensure that the level is in accordance with the requirements. Over voltage and voltage ripple may damage the product.</li> <li>◆ Make sure that the analog voltage signal does not exceed 10V, otherwise the product may be damaged.</li> </ul>
--	---

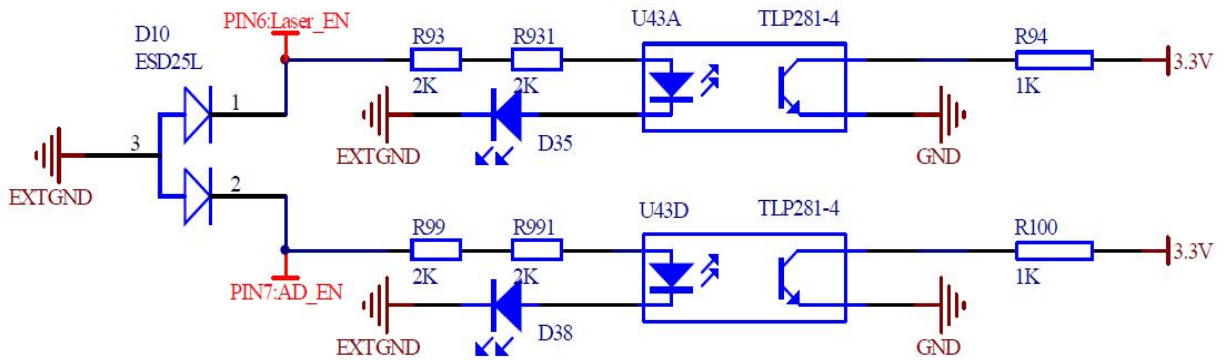

Figure 12 PIN6、PIN7 Internal Circuit

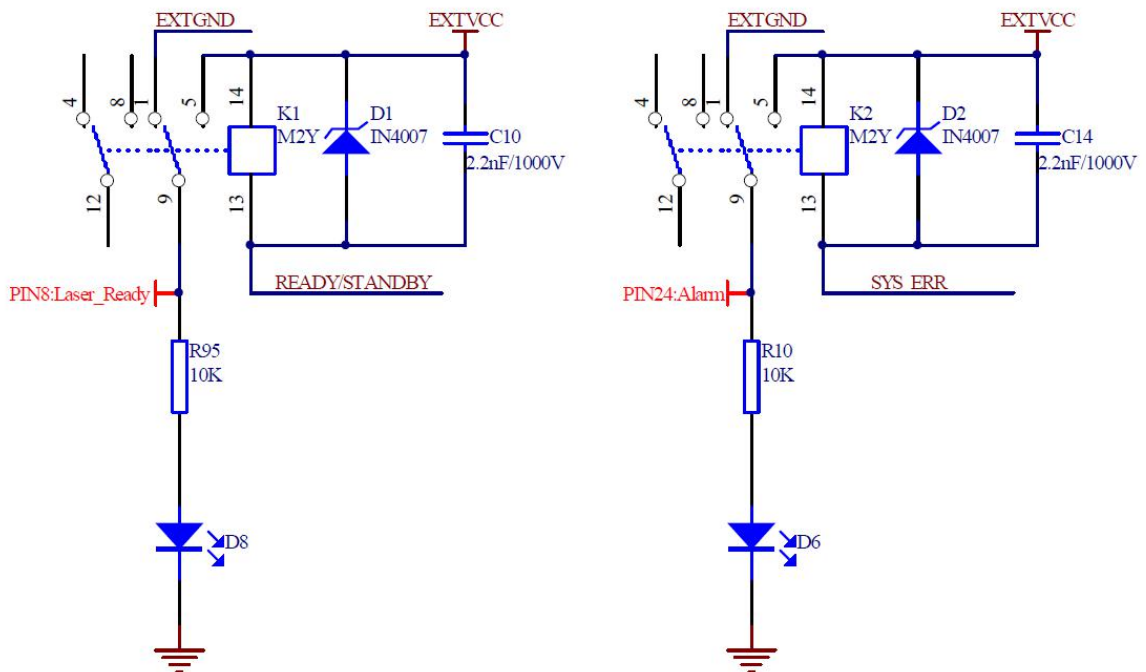

Figure 13 PIN8 and PIN24 internal circuit

#### 4.3.4 RS-232 Serial Port

Figure 14 shows the pin number of RS-232 serial port:

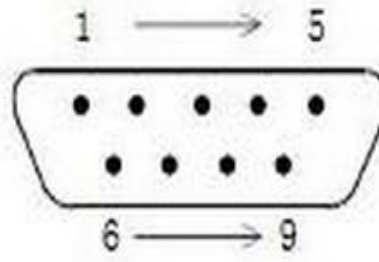

Figure 14 Pin Number of RS-232 Serial Port

And the definitions of the pins are in the following table:

Table 11 RS-232 Serial Port Definitions

PIN	Description
2	RX
3	TX
5	GND
Others	NC

### 4.3.5 TCP/IP Interface Configuration

The default IP address of this product is 192.168.0.10, only supports UDP communication. The laser listens for connection on port is 8098, and the command must be sent in a single data string.

Table 12 The Pins Definition of Ethernet Interface

PIN	FUNCTION	DESCRIPTION
1	TX+	TRANSMIT+
2	TX-	TRANSMIT-
3	RX+	TRANSMIT+
4	N/C	NONE
5	N/C	NONE
6	RX-	RECEIVE-
7	N/C	NONE
8	N/C	NONE

For better communication stability, recommend to use this interface first.

The steps of Ethernet connection:

- a) Open the Raycus PC software, click "Session → RS232 (or Ethernet)" to make the PC communicate with the laser, and then click "Tool → Laser IP Set" to enter the laser IP address setting;
- b) The default password is "1122334455667788". After the verification is passed, reador set the new laser IP address.
- c) If you use the Raycus PC software to control thelaser, you need to find the folder where the PC software is located, open the laser configurationfile “config.xml”, and write the newly laser IP address. If you do not use Raycus software, pleasego to the step 4;
- d) Configure TCP/IP, select "Use the following IP address", manually assign an IPaddress, and the IP address of the PC must be in the same network segment as the laser IPaddress, and assign a subnet mask address. The default is 255.255.255.0, click the "OK" buttoonto confirm the settings and exit.

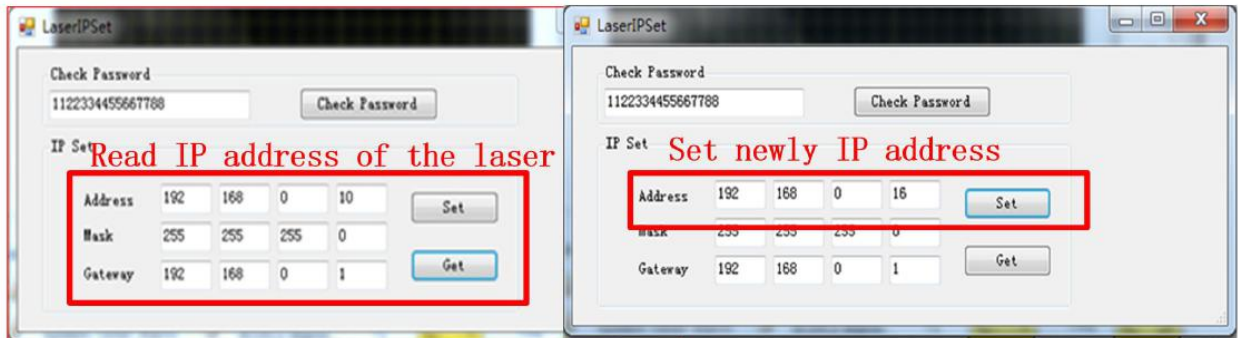

If you do not use Raycus software, please go to the step 4

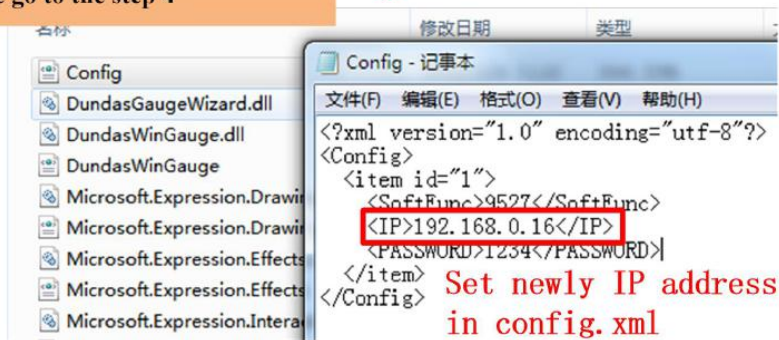

Set newly IP address in config.xml

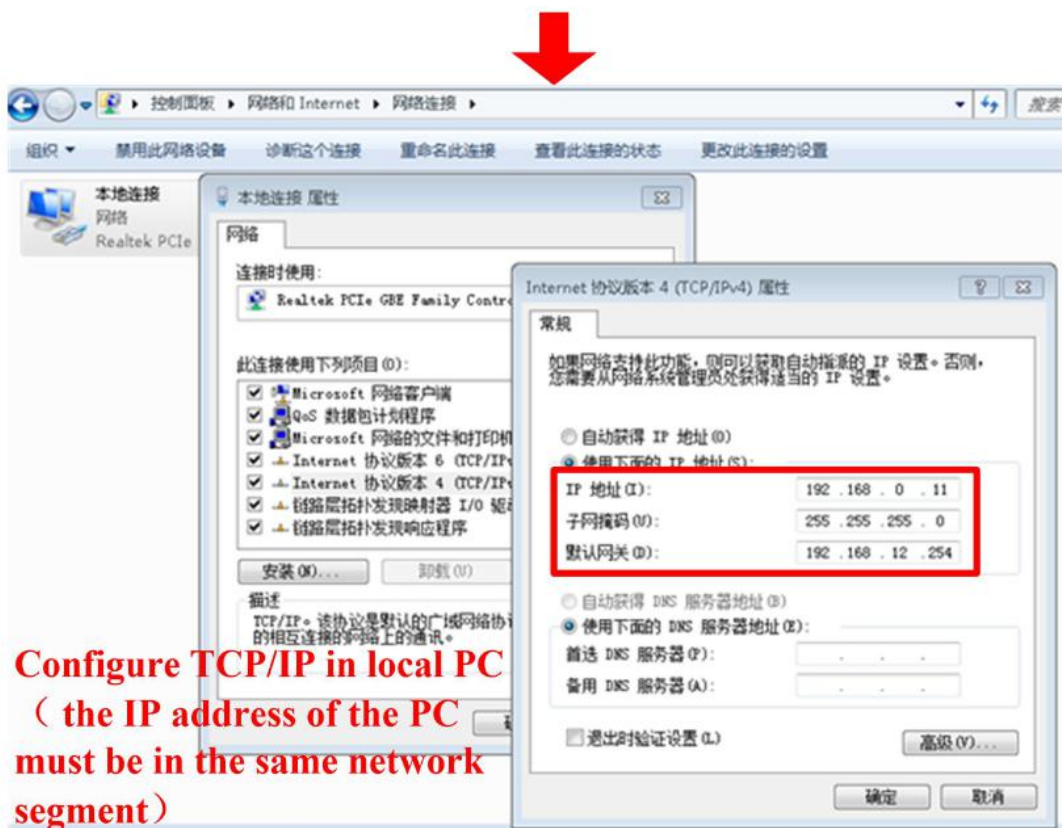

Configure TCP/IP in local PC ( the IP address of the PC must be in the same network segment )

Figure 15 The Steps of Ethernet Connection

#### 4.4 Work Patterns and Control Modes

There are two work patterns for the laser: CW(continuous wave)and pulse pattern. In CW pattern, the laser emits continuously. As for pulse pattern, The output beam oflaser is pulsing, transform the waveform by setting frequency, duty ratio and the percentage of power.

There are threecontrol modes to choose, external control RS-232 mode, external control AD mode, and Internal controlmode. RS-232 mode is to set up parameters and control laser enable signal externally. AD mode is to set up parameters (MOD, Analog Quantity) and control laser enable signal externally. Internal control mode is to set up parameters and control laser enable signal internally. Each control modes can be achieved in two work patterns: CW mode, pulse mode.

#### 4.5 Operating Process

All electrical connections must be finishedbefore the laser is powered up;

- a) Make sure that the pins 6 and 7 of DB9 SERVICEinterface are connected.
- b) Turn on the chiller, check that if it is working properly.
- c) Connect AC power.
- d) Short-circuit the SERVICE interface “POWERA” and “POWERB” to enable laser.

#### 4.6 Selection of Control Mode

Raycus provide assorted upper computer software, as shown in Figure 17(Download theRsycus software and software manual, please log in to Raycus official website).

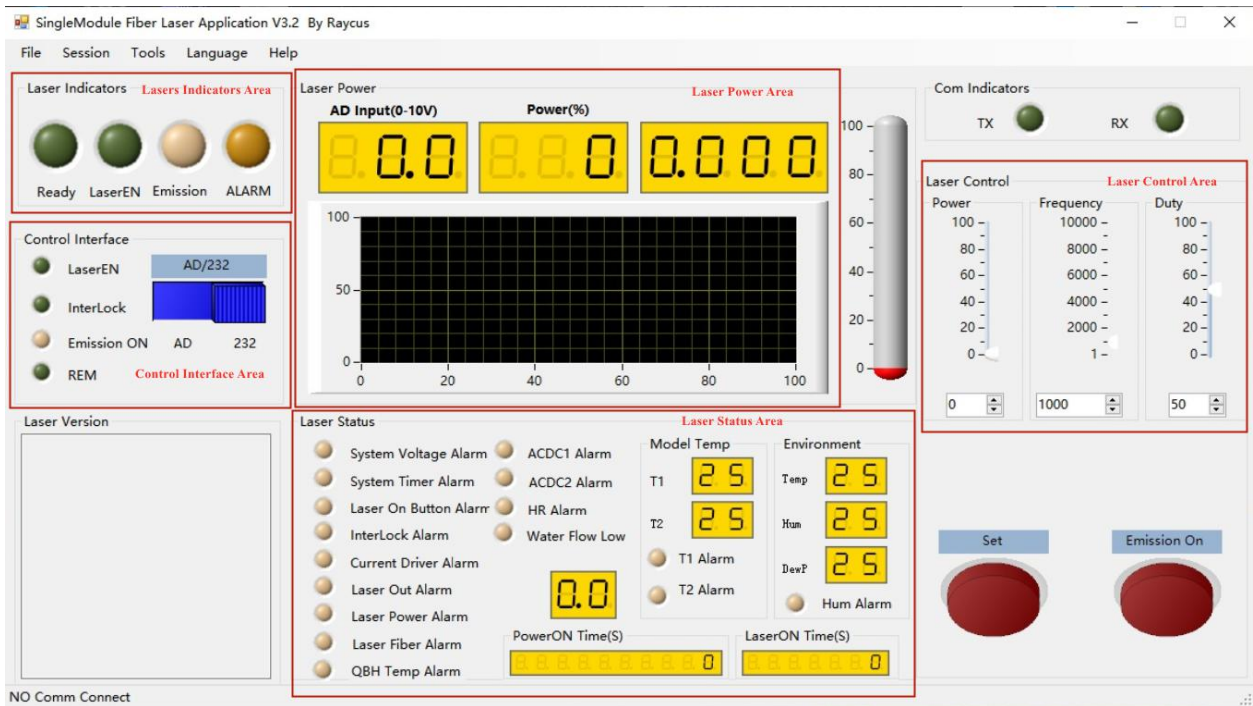

Figure 16 The Function Area of Upper Computer Software

Table13 Brief Description of Each Functional Area

Functional Area	Description
Laser Indicators	‘Ready’——The laser complete
	‘Laser EN’——Enable Signal
	‘Emission’——The laser is emitting laser
	‘Alarm’——Laser alarm
Control Interface	‘Laser EN’——Control Interface’s the pin LASER ON is high level
	‘Interlock’——Control Interface’s the InterLock is on
	‘Emission’——The laser is emitting laser
	‘REM’——The laser is now in External Control mode
	‘AD’——The laser is now in External AD Control mode, laser power is controlled by external 0-10V
	‘232’——The laser is now in External RS232 mode, laser power is controlled by software
Laser Power	The output power percentage or Analog Quantity
Laser Status	The laser’s internal state, State Monitoring

Laser Control	Set parameters: Laser Power, Frequency, Duty Ratio
	‘Set’——After Setting parameter, Need to click ‘set’
	“Emission on”——Pressing the button, the laser is emitting laser; button is unavailable, the laser is being shut down.

#### 4.6.1 Wiring in External RS-232

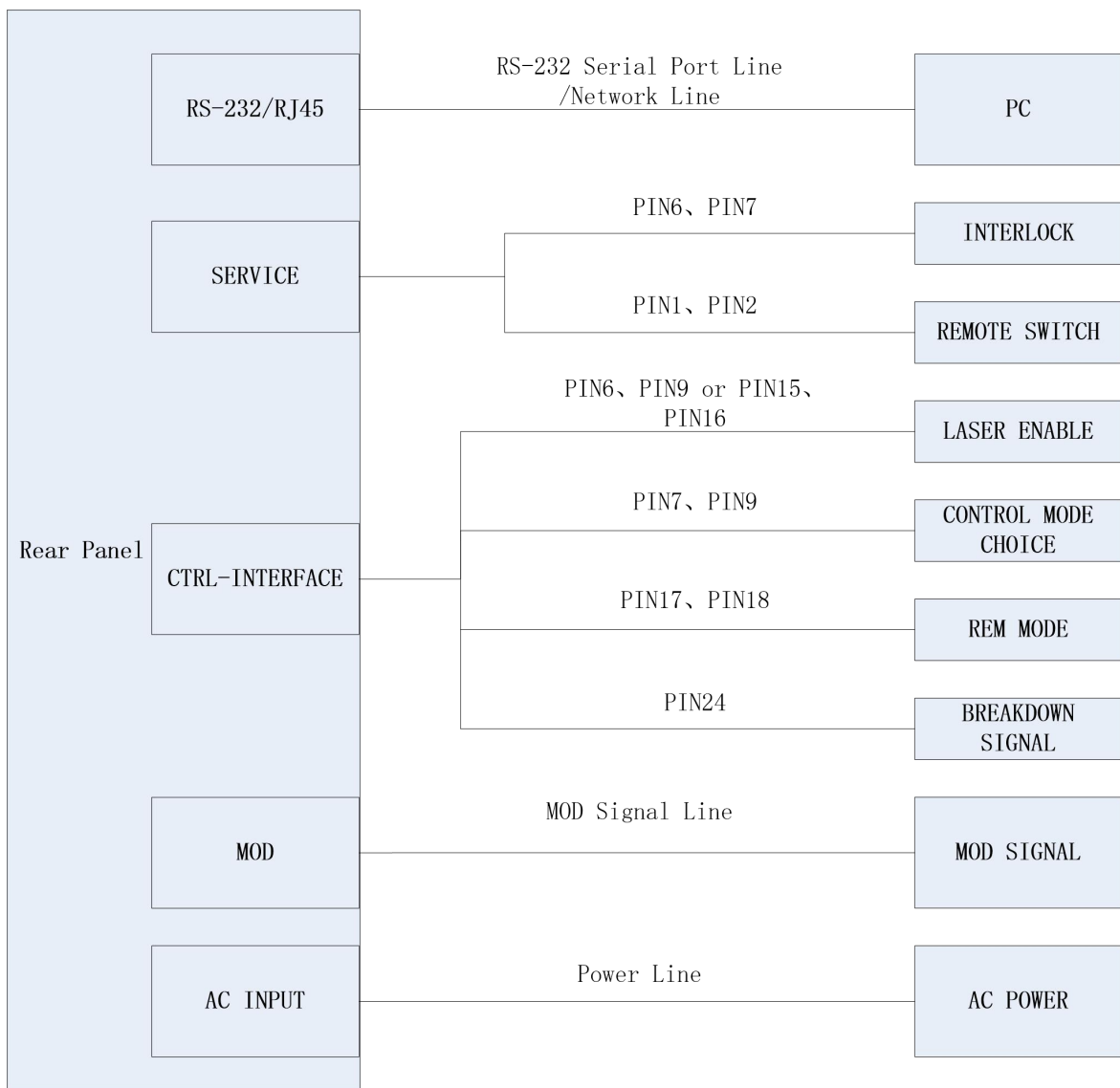

Figure 17 Wiring in external RS-232 mode

#### 4.6.2 External RS232 Mode Operation Procedure

- a) Short-circuit DB25 control interface's PIN17 and PIN18, Select external control mode.
- b) Ensure disconnect DB25 control interface's PIN7 and PIN19. Enable external control RS-232 Mode.
- c) Connect AC power, The laser's front panel 'Power' is on.
- d) Wait 10s, The internal circuit initialization phase is complete;
- e) Setting the laser power by upper computer software;
- f) The MOD interface provides modulating signal for the laser;
- g) Enable the laser through one of the following ways:
  - 1) PIN 6-9 of the DB25 control interface is applied to 24V. – laser enable signal
  - 2) The upper computer software sends enablesignal. – laser enable signal
  - 3) Short-circuit DB25 control interface's PIN15 and PIN16. – laser enable signal

#### 4.6.3 The Sequence Diagram of External Control RS232 mode

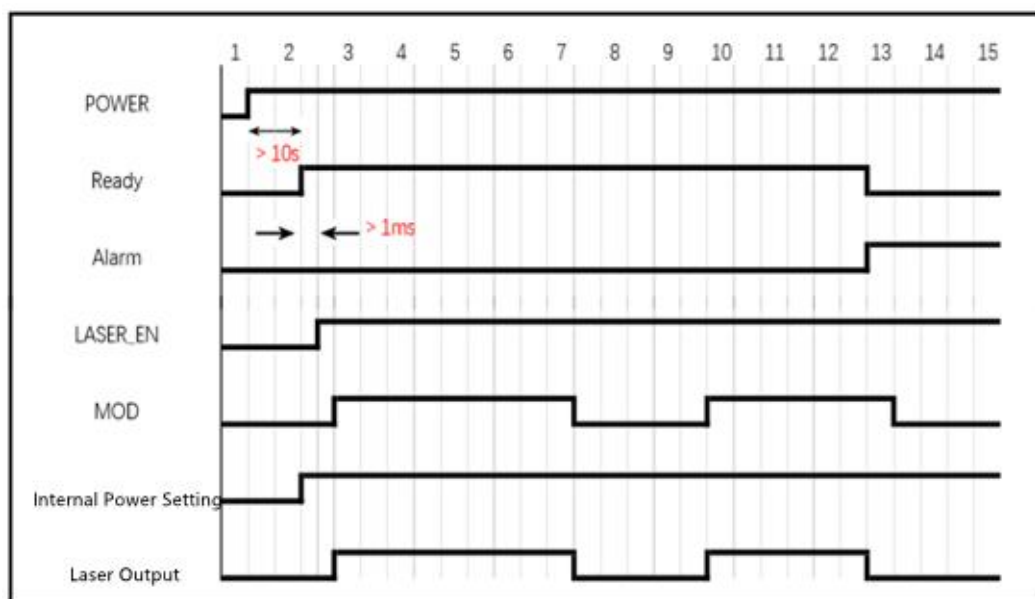

Figure 18 Control Sequence Diagram of CW Pattern in External Control RS232 Mode

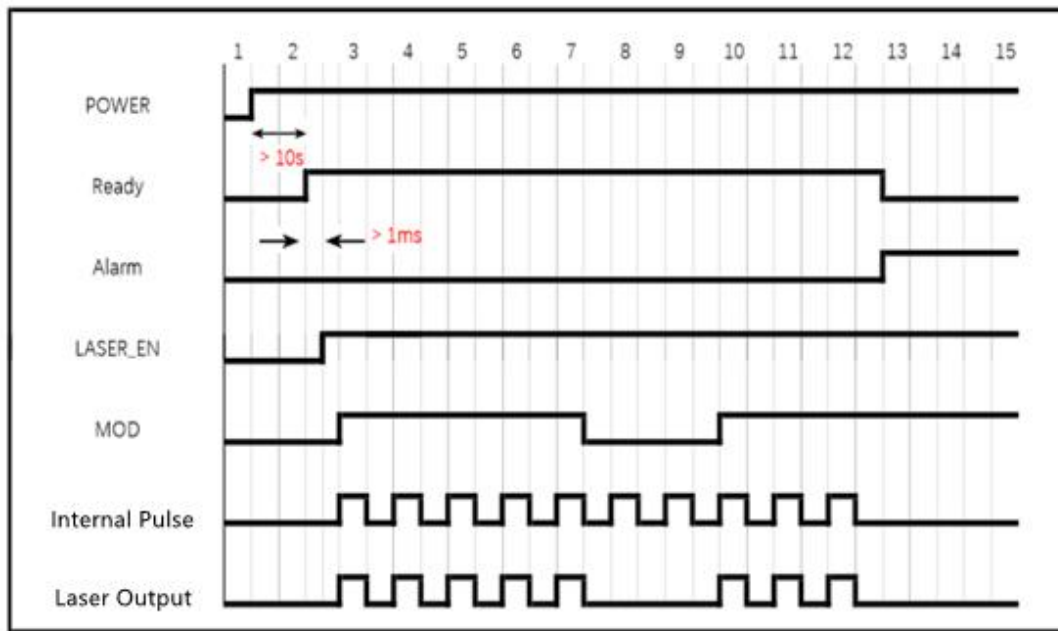

Figure 19 Control Sequence Diagram of PLUSE Pattern in External Control RS232 Mode

#### 4.6.4 Wiring in External Control AD mode

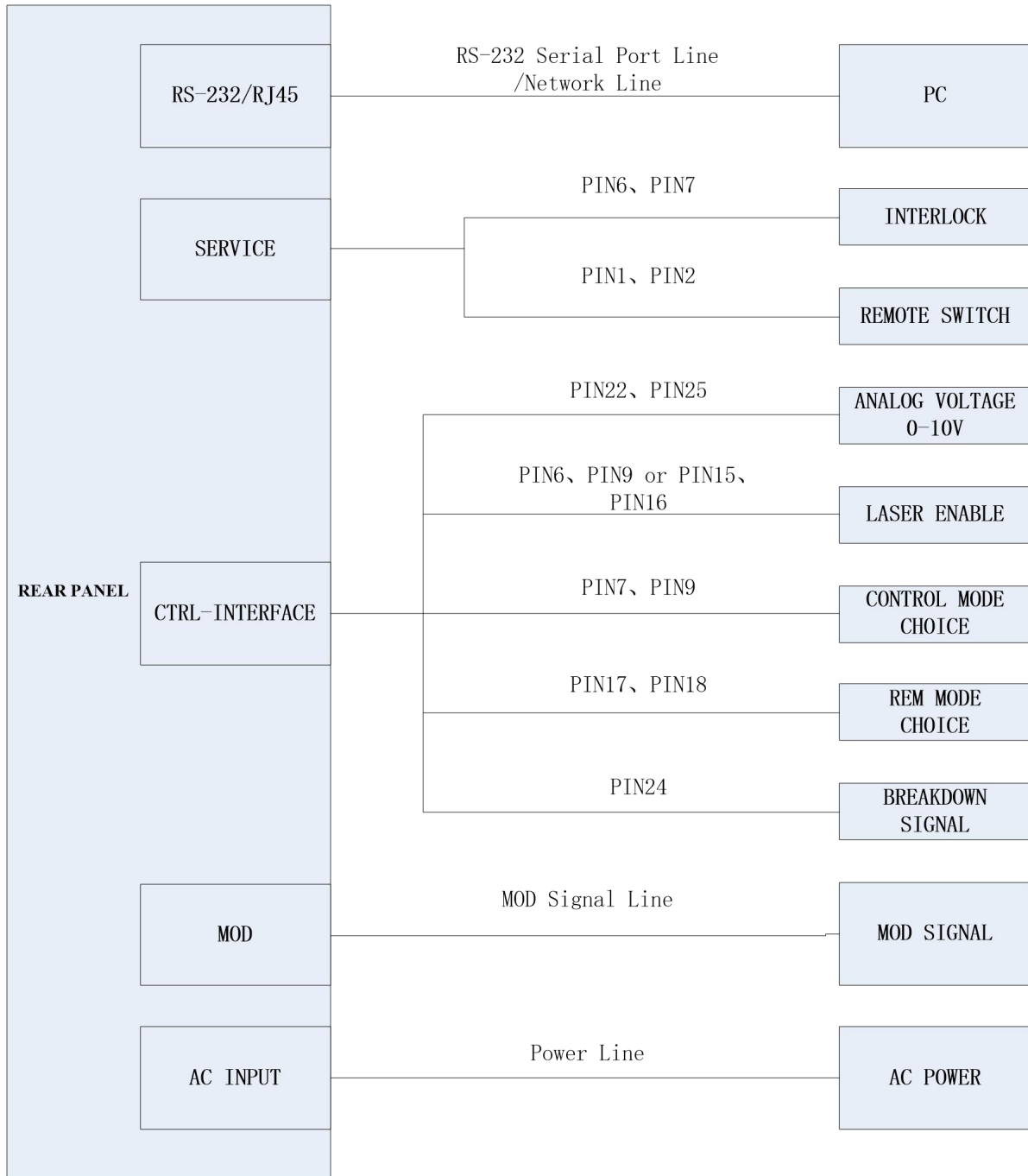

Figure 20 Wiring In External Control AD Mode

#### 4.6.5 The Operation Procedure of External AD mode

- a) Short-circuit DB25 control interface's PIN17 and PIN18, Select external control mode.

- b) When PIN 7-9 of the DB25 control interface is applied to 24V, the laser enters the externalAD mode.
- c) Connect to AC power, and the “Power” indicator on the front panellight on.
- d) Waiting for 10s until the internal main control board circuit initialization is completed.
- e) The power of the laser is controlled by the voltage obtained by PIN 22-25 of theDB25 interface connector.
- f) The external MOD interface provides modulating signal for the laser.
- g) Enable the laser through one of the following ways:
  - 1) PIN 6-9 of the DB25 control interface is applied to 24V. – laser enable signal.
  - 2) The upper computer software sends enablesignal. – laser enable signal.
  - 3) Short-circuit DB25 control interface’s PIN15 and PIN16. – laser enable signal.

#### 4.6.6 The Sequence Diagram of External AD mode

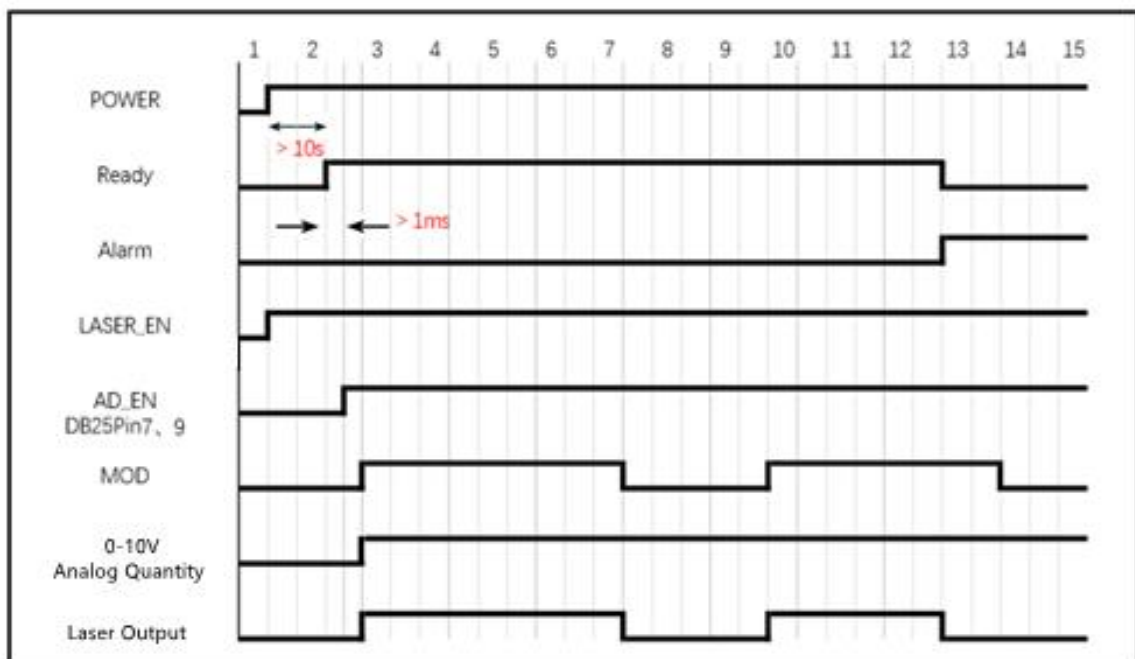

Figure 21 Control Sequence Diagram of ADMode

#### 4.6.7 Wiring in Internal Control Mode

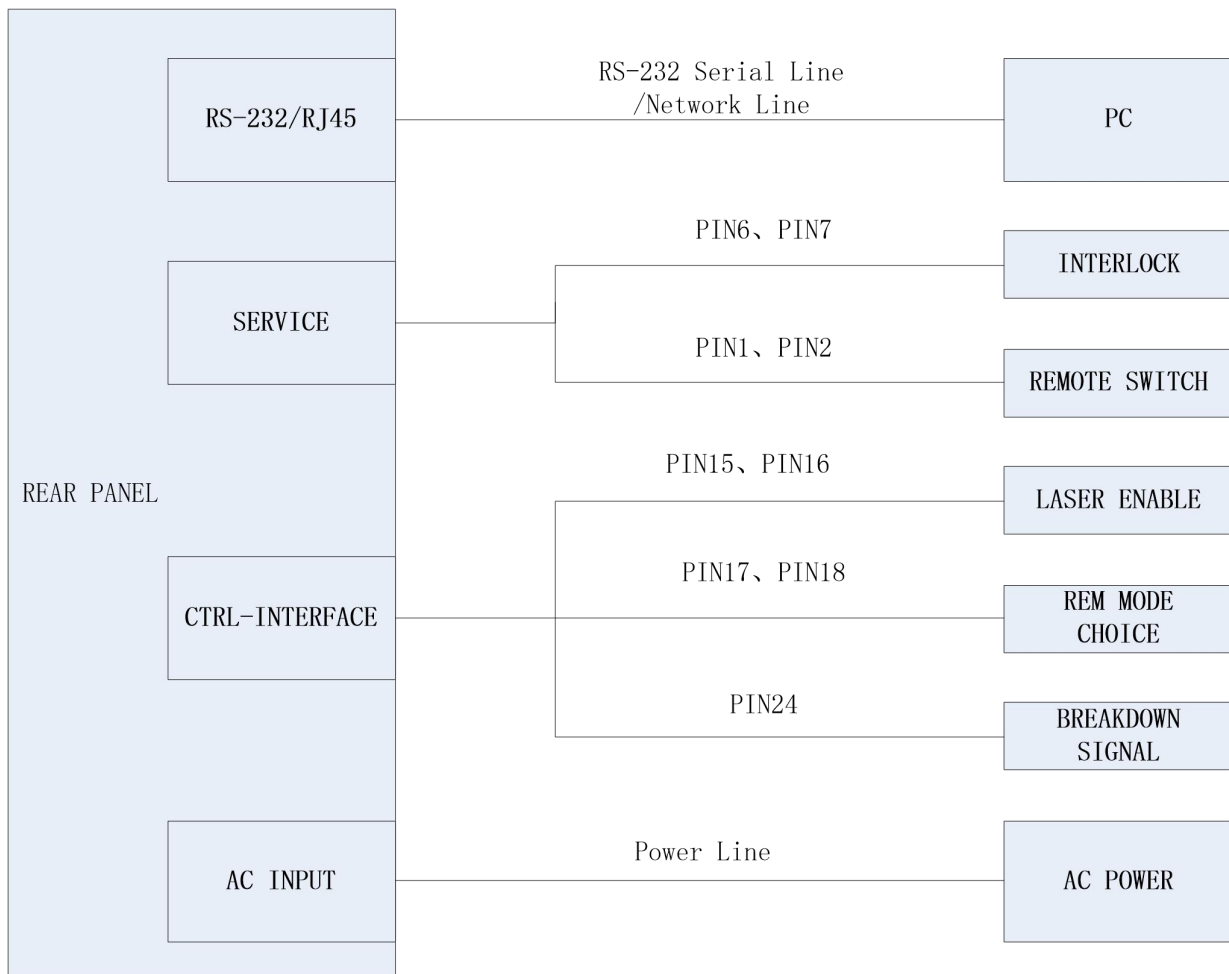

Figure 22 Wiring in Internal Control Mode

#### 4.6.8 The Operation Procedure of Internal Control Mode

- a) Disconnect DB25 control interface's PIN17 and PIN18, Select internal control mode.
- b) Connect to AC power, and the "Power" indicator on the front panel light on;
- c) Waiting for 10s until the internal main control board circuit initialization is completed;
- d) Setting the power of the laser by upper computer software, then send a command of emitting laser.
- e) Short-circuit DB25 control interface's PIN15 and PIN16 to enable the laser.

#### 4.6.9 The Sequence Diagram of Internal Control Mode

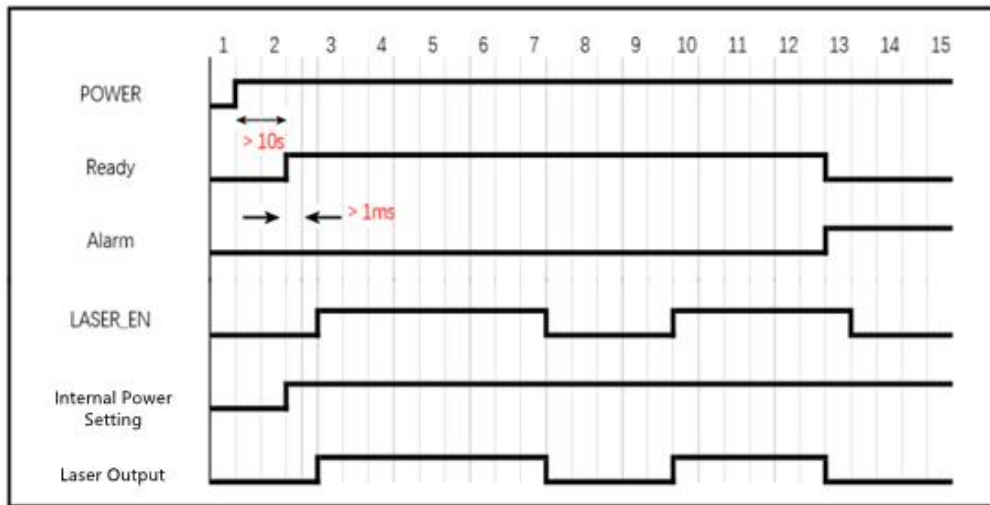

Figure 23 Control Sequence Diagram of CW Mod in Internal Control Mode

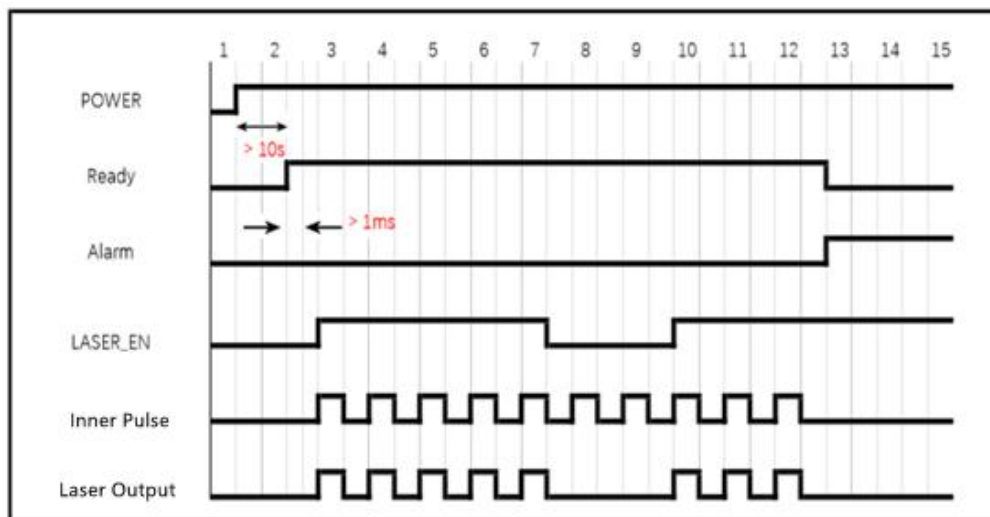



Figure 24 Control Sequence Diagram of PulseMod in Internal Control Mode

#### 4.7 PilotLight to Control

Connect to AC power, Both 'POWER' green indicator light and the laser generate pilot light are on. When laser enable signal is on, Pilot light is off; when laser enable signal is off, Pilot light is on.

	<p>◆ The pilot light and laser beam cannot exist simultaneously. If there is no pilot light, please check if the laser enable signal is off.</p>
---	--

## 4.8 Steps of Shutting Down

Please turn off the laser in the order below:

- a) Turn off the emission.
- b) Disconnect power supply.
- c) Turn off the chiller.

## 5 Alarms and Solutions

### 5.1 Alarms Display

Connect computer and establish communication with the client software, all alarm states of the laser can be displayed on the client software homepage. When inner temperature, output power, Power supply, moisture condensation is abnormal, the laser will send out alarm information.

If any alarm occurs (except for Interlock alarm) when the laser is running, the homepage will display the alarm that occurs, and the ALARM light (yellow) on the front panel of the laser will light up, the laser will stop emitting and lock.

When the Interlock is abnormal, the output of Ready signal is low, and the Interlock state is abnormal in the software homepage, but the laser is not locked, and the ALARM light (yellow) is not lit. The output of Ready signal is on high level when the Interlock is normal.

### 5.2 Alarm Solutions

The instructions and solutions of alarms are as follows:

Table 14 Instructions and Solutions for Alarms of Laser

Alarm name	Alarm instructions and solutions
System Timer Alarm	<p><b>Instruction:</b> The internal clock of laser is abnormal.</p> <p><b>Solution:</b> If it displays this alarm, please contact Raycus.</p>
Laser On Button Alarm	<p><b>Instruction:</b></p>

	<p>This alarm occurs, Pin15 and Pin 16 in the ‘CTRL-INTERFACE’ interface has been connected before the laser is powered on.</p> <p><b>Solution:</b> Please power off and disconnect Pin15 and Pin 16 in the ‘CTRL-INTERFACE’ interface the “LASER” button. Repower and check if the alarm is resolve. If this alarm continues to occur, please contact Raycus.</p>
InterLock Alarm	<p><b>Instruction:</b> Occurs when the InterLock is disconnected.</p> <p><b>Solution:</b> Short the InterLock pins and restart the laser to try. If this error continues to occur, please contact Raycus.</p>
Current Driver Alarm	<p><b>Instruction:</b> Current Driver Alarm, this error occurs when the constant current driver board inside the laser is abnormal.</p> <p><b>Solution:</b> Restart the laser, If this error continues to occur, please contact Raycus.</p>
Laser Power Alarm	<p><b>Instruction:</b> The laser will get this error when it does not emit with correct settings. Power error occurs only when the laser is emitting.</p> <p><b>Solution:</b> Restart the laser, if this error continues to occur, please contact Raycus.</p>
ACDC1 Alarm	<p><b>Instruction:</b> ACDC1 Error, failure of the laser power supply or sudden power failure of the power supply system may cause an alarm.</p> <p><b>Solution:</b> Check if the input AC voltage is normal. Restart the laser, if this error continues to occur, please contact Raycus.</p>
T1/T2/T3/T4 Alarm	<p><b>Instruction:</b> Low temperature/high temperature alarm of the laser. The sensor in the laser detects an abnormal temperature inside the laser. A high-temperature / low-temperature error occurs when the temperature at the monitoring point exceeds the set upper / lower limit.</p> <p><b>Solution:</b> High temperature alarm, please check if the water-cooling system is normally working, the water temperature is set correctly, and the water connection is correct. When the water cooling system works normally and the water temperature drops below 30°C, restart the laser. If the alarm continues, please contact Raycus. Low temperature alarm, please check if the actual water temperature of the water is too low. In addition, a low ambient temperature may also cause a low temperature alarm when the laser is cold. Please wait until the water temperature of the water rises above 10°C. If the alarm continues, please contact Raycus.</p>
Hum Alarm	<p><b>Instruction:</b> The laser detects that the current water-cooled plate temperature is lower than the internal dew point temperature, There is a risk of condensation in the equipment internal.</p> <p><b>Solution:</b> Stop using the laser immediately, Waiting for ambient temperature to come back to normal, Repower the laser. If the alarm continues to occur, please contact Raycus.</p>

In addition to the above, if there are any questions or errors in using of the laser, you can contact Raycus to get help.

## 6 Warranty, Return and Maintenance

### 6.1 General Warranty

Raycus warrants that all Raycus fiber laser products are conformed to applicable products specifications under normal use and are free from defects in materials and workmanship. The warranties start on the date of shipment from Raycus for a period of time as set forth in the applicable purchase contracts or product specifications.

Raycus has the right to choose to repair or replace any product that proves to be defective in materials and workmanship selectively during the warranty period. Only products with particular defects are under warranty. Raycus reserves the right to issue a credit note for any defective products produced in normal conditions.

### 6.2 Limitations of Warranty

The warranty does not cover the maintenance or reimbursement of our product of which the problem results from tampering, disassembling, misuse, accident, modification, unsuitable physical or operating environment, improper maintenance, damages caused by those who are not from Raycus due to excessive use or not following the instructions. Customer has the responsibility to understand and follow this instruction to use the device. Any damage caused by fault operating is not warranted. Accessories and fiber connectors are excluded from this warranty.

According to the warranty, client should write to us within 31 days after the defect is discovered. This warranty does not involve any other party, including specified buyer, end-user or customer and any parts, equipment or other products produced by other companies.

	◆ It is the customer's responsibility to understand and follow operating instructions in this User Guide and specifications prior to operation-failure to do so may void this warranty. Accessories and fiber connectors are not covered by this warranty.
---	--

### 6.3 Service and Repair

- a) Do not open the device. There are no user serviceable parts, equipment or assemblies for user in this product. All service and maintenance shall be performed by qualified Raycus personnel.



- b) Please contact Raycus as soon as possible when problems under warranty about maintenance happened to the product.
- c) The product returned with permission should be placed in a suitable container.
- d) If any damage happened to the product, please notify the carrier in document immediately.

We reserve the right to make changes in design or constructions of any of our products at any time without incurring any obligation to make changes or install the same on units previously purchased.

All the items about warranty and service above provided by Raycus are for user's reference; formal contents about warranty and service are subject to the contract.