



# **Fiber Delivered Direct Diode Lasers**

## **User Guide**

RFL-A4000D

RFL-A6000D      RFL-A8000D

RFL-A10000D    RFL-A12000D

## CONTENTS

<b>1</b>	<b>SAFETY INFORMATION .....</b>	<b>1</b>
1.1	SECURITY LABELS .....	1
1.2	LASER SAFETY GRADE .....	2
1.3	OPTICAL SAFETY .....	2
1.4	ELECTRICAL SAFETY .....	2
1.5	OTHER SAFETY RULES .....	3
<b>2</b>	<b>PRODUCT DESCRIPTION .....</b>	<b>3</b>
2.1	FEATURES .....	3
2.2	PACKAGE PARTS .....	4
2.3	UNPACKING AND INSPECTION .....	4
2.4	OPERATION ENVIRONMENT .....	4
2.5	ATTENTIONS .....	5
2.6	SPECIFICATIONS .....	5
<b>3</b>	<b>INSTALLATION .....</b>	<b>6</b>
3.1	DIMENSIONS .....	6
3.2	INSTALLATION RULES .....	10
3.3	COOLING REQUIREMENTS .....	12
<b>4</b>	<b>USING THE PRODUCT .....</b>	<b>13</b>
4.1	FRONT PANEL .....	14
4.2	REAR PANEL .....	15
4.3	POWER CONNECTION .....	16
4.4	CONTROL INTERFACE DEFINITION .....	18
4.4.1	SAFETY XP2 INTERFACE .....	18
4.4.2	HARD WIRING XP1 .....	23
4.4.3	RS232 XP3 INTERFACE .....	25
4.4.4	ANALOG INTERFACE XP4 .....	25
4.4.5	INTERNET INTERFACE XP5 .....	26
4.5	INTRODUCTION TO SAFETY INTERLOCK .....	26
4.6	SCHEMATIC DIAGRAM OF THE INTERNAL ELECTRICAL CIRCUIT OF THE LASER .....	27
4.7	START OPERATION SEQUENCE .....	28
<b>5</b>	<b>CONTROL MODE SELECTION .....</b>	<b>29</b>





5.1	ON MODE .....	31
5.1.1	AD ENABLE MODE .....	31
5.1.2	EMISSION EXTERNAL CONTROL ENABLE .....	31
5.1.3	RED LIGHT CONTROL.....	31
5.1.4	PROGRAMMING MODE .....	31
5.2	REM MODE .....	32
5.2.1	AD ENABLE MODE .....	32
5.2.2	EMISSION EXTERNAL CONTROL .....	32
5.2.3	RED LIGHT CONTROL.....	32
5.2.4	PROGRAMMING MODE .....	32
<b>6</b>	<b>WIRING DIAGRAM AND OPERATION STEPS .....</b>	<b>33</b>
6.1	INTERNAL CONTROL IN ON MODE .....	33
6.2	EMISSION EXTERNAL CONTROL MODE SET BY POWER COMMUNICATION IN ON MODE.....	34
6.3	EMISSION EXTERNAL CONTROL SET BY POWER ANALOG IN ON MODE .....	35
6.4	EMISSION EXTERNAL CONTROL THROUGH PROGRAMMING MODE ON THE ON MODE.....	36
6.5	SET THE POWER ANALOG AS EMISSION EXTERNAL CONTROL ON THE REM MODE.....	37
6.6	REM MODE POWER COMMUNICATION SET OUT LIGHT EXTERNAL CONTROL.....	39
6.7	PROGRAMMING MODE IN REM MODE .....	40
<b>7</b>	<b>RS232 AND INTERNET COMMUNICATION COMMAND .....</b>	<b>41</b>
7.1	PORT CONFIGURATION .....	41
7.2	LASER COMMUNICATION PROTOCOL (NETWORK PORT & SERIAL PORT).....	41
<b>8</b>	<b>PC SOFTWARE INSTRUCTIONS.....</b>	<b>46</b>
8.1	MAININTERFACE OF PC SOFTWARE .....	46
8.2	MULTI-LASER CONTROL AREA.....	46
8.2.1	ADD/DELETE LASER .....	47
8.2.2	MODIFY LASER IP .....	48
8.3	MAIN WORKING STATUS DISPLAY.....	49
8.3.1	LASER'S CUMULATIVE OPERATING TIME DISPLAY AREA.....	49
8.3.2	LASER WORKING STATUS DISPLAY AREA .....	50
8.3.3	LASER POWER-UP, MODE SELECTION, LIGHT-OUT CONTROL AREA .....	51
8.3.4	PROGRAMMING MODE TEST AREA .....	52
8.3.5	POWER SLOW RISE & DOWN PARAMETER SETTING AREA .....	52
8.3.6	LASER OUTPUT PARAMETERS READ THE SETTING AREA .....	53

8.4	LASER STATUS DISPLAY AREA.....	53
8.5	ALARM TYPE DISPLAY AREA .....	54
8.6	PC SOFTWARE OPERATING MODE SELECTION .....	54
8.7	LANGUAGE.....	55
8.8	AUTHORIZATION (TIME-LIMITED LOCKING).....	56
8.8.1	AUTHORIZATION ON USER MODE .....	56
8.8.2	AUTHORIZATION ON AUTHORIZATION MODE .....	56
8.9	ABOUT .....	57
8.10	XP1 INTERFACE STATUS INDICATION (IN DIAGNOSTIC MODE) .....	58
8.11	LOG (IN DIAGNOSTIC MODE) .....	58
8.11.1	DOWNLOAD LOG .....	59
8.11.2	DOWNLOAD RECORD OF HISTORICAL FAULT.....	59
8.11.3	DOWNLOADED FILE ADDRESS .....	60
8.12	MODULE PARAMETERS (IN DIAGNOSTIC MODE) .....	60
8.13	PROGRAMMING SETTINGS (PROGRAMMING EDITING).....	60
8.13.1	VIEW THE NUMBER OF WAVE BARS INSIDE THE CURRENT LASER .....	61
8.13.2	CHECK PROGRAMMING CONTENT .....	62
8.13.3	EMPTY ALL PROGRAMMING.....	62
8.13.4	EDIT PROGRAMMING .....	63
8.13.5	COMMAND EXPLANATION .....	65
<b>9</b>	<b>WARRANTY, REPAIR AND RETURN .....</b>	<b>66</b>
9.1	GENERAL WARRANTY .....	66
9.2	LIMITATIONS OF WARRANTY .....	66
9.3	SERVICE AND REPAIR.....	67

## 1 Safety Information

Thank you for choosing Raycus Fiber Delivered Direct Diode Laser. This user manual provides you with important safety, operation, maintenance and other relevant information. Please read the manual carefully before using this product. To ensure safe operation and optimum product operation, please observe the following cautions and warnings as well as other information within this manual.

### 1.1 Security Labels

	<p><b>WARNING:</b> Describes a hazard that leads to severe personal injury or death.</p>	
	<p><b>CAUTION:</b> Describes a hazard that leads to general personal injury or damages to product.</p>	
<div style="border: 1px solid black; padding: 5px; margin-bottom: 10px;"> <p style="text-align: center;">AVOID EXPOSURE VISIBLE AND/OR INVISIBLE LASER RADIATION IS EMITTED FROM THIS APERTURE <small>Per GB 7247.1-2012/IEC 60825-1:2007</small></p> </div> <p style="text-align: center;">English</p> <div style="border: 1px solid black; padding: 5px;"> <p style="text-align: center;">激光窗口 避免受到从本窗口射出的 激光辐射的照射 <small>GB 7247.1-2012/IEC 60825-1:2007</small></p> </div> <p style="text-align: center;">Chinese</p>	<div style="border: 1px solid black; padding: 5px; margin-bottom: 10px;"> <p style="text-align: center;">MAX.AVERAGE OUTPUT POWER:6000W CW WAVELENGTH RANGE:900-1200nm DANGER-VISIBLE AND/OR INVISIBLE LASER RADIATION AVOID EYE OR SKIN EXPOSURE TO DIRECT OR SCATTERED RADIATION CLASS 4 LASER PRODUCT <small>Per IEC 60825-1:2014</small></p> </div> <p style="text-align: center;">English (6000W)</p> <div style="border: 1px solid black; padding: 5px;"> <p style="text-align: center;">最大平均输出功率: 6000W CW 波长范围: 900-1200nm 可见及不可见激光辐射 避免眼或皮肤受到直射或散射辐射的照射 4类激光产品 <small>GB 7247.1-2012/IEC 60825-1:2007</small></p> </div> <p style="text-align: center;">Chinese (6000W)</p>	<div style="border: 1px solid black; padding: 5px; margin-bottom: 10px;"> <p style="text-align: center;">MAX.AVERAGE OUTPUT POWER:1mW WAVELENGTH RANGE:600-700nm VISIBLE LASER RADIATION DO NOT STARE INTO BEAM OR EXPOSE USERS OF TELESCOPIC OPTICS CLASS 2 LASER PRODUCT <small>Per IEC 60825-1:2014</small></p> </div> <p style="text-align: center;">English</p> <div style="border: 1px solid black; padding: 5px;"> <p style="text-align: center;">最大平均输出功率: 1mW 波长范围: 600-700nm 可见激光辐射 勿直视或通过光学仪器直接观看光束 2类激光产品 <small>GB 7247.1-2012/IEC 60825-1:2007</small></p> </div> <p style="text-align: center;">Chinese</p>
<p style="text-align: center;">1: Laser Emit Head</p>	<p style="text-align: center;">2: Type 4 Laser Product</p>	<p style="text-align: center;">3: Class 2M Laser Product Label-2mW Red Laser</p>
		
<p style="text-align: center;">4: CE Authentication</p>	<p style="text-align: center;">5: Laser Radiation Hazard</p>	<p style="text-align: center;">6: Electrical Hazard</p>

## 1.2 Laser Safety Grade

This series of lasers are Class 4 laser instruments. The product emits laser radiation at a wavelength of 915nm or around 915nm, and the average laser power radiated from the fiber delivery cable connector is 4kW~12kW (depending on laser model). Direct or Indirect exposure to high power laser radiation causes damage to the eye or skin. Although the radiation is not visible, the beam will cause irreparable damage to the retina or cornea, so appropriate and certified laser safety glasses must be worn whenever the laser is emitting.

	<p><b>WARNING:</b> Users must use appropriate laser goggles when operating this device. The laser goggles are selected according to the range of wavelength emitted from this product. Users must select the appropriate laser goggles according to the entire range of laser wavelengths. Please do not directly view (whether the laser is emitting or not) the laser output heads when laser emitting.</p>
---	---

## 1.3 Optical Safety

Any dust on the end of the collimator assembly can damage the lens or the entire laser device.

	<p><b>CAUTION:</b> DO NOT emit when the protective cap is not removed, otherwise the lens or crystal will be damaged.</p>
---	---

## 1.4 Electrical Safety

- a) Ensure that the PE line is effectively grounded, and the installation environment is safe and reliable.

	<p><b>WARNING:</b> The disconnection of the product grounding will electrify the outer shell, which may result in personal injury to the operator.</p>
---	--

- b) Ensure that the AC voltage is supplied normally.



**CAUTION:** Wrong wiring mode or power supply voltage will cause irreversible damage to the laser device.

## 1.5 Other Safety Rules

- a) Do not view the laser output head directly when laser emitting.
- b) Do not use fiber lasers in dark or dim environments.
- c) If this device is used in a manner not specified in this manual, the protection provided by the device may be impaired and the warranty will be voided.
- d) There are no user serviceable parts, equipment or assemblies inside the product. All service and maintenance shall be conducted by a certified Raycus engineer. In order to prevent electric shock, please do not break the seal or uncover the shield. Otherwise, any damage to the device will not be guaranteed.

## 2 Product Description

### 2.1 Features

Fiber delivered direct diode lasers are more compact and ready to use than conventional lasers, with higher electrical and optical conversion efficiencies, lower power consumption and better beam quality. Thanks to its flexible laser output ways, it can be easily integrated with system equipment.

Main Features:

- Flexible output
- Highly reliable and long service life
- Maintenance-free operation
- High electro-optical conversion efficiency
- Convenient control interface
- Fast modulation

Product's main applications:

- Industrial cutting and welding
- Laser quenching and cladding
- Scientific research

## 2.2 Package Parts

Please refer to package accessories that are in the packing box.

## 2.3 Unpacking and Inspection

The specially designed packaging materials and cabinets helps Raycus ensures that the lasers are fully protected during transportation. Nevertheless, in order to prevent unpredictable situations during transportation, the users still need to carefully check whether the package is correctly placed before unpacking, and there is no damage from phenomenon such as collision, cracking and flooding on the outside of the box. Once you find that there is an abnormality in the external cabinet, please inform Raycus Company in time to deal with it as soon as possible.

Please double check if each listed object is inside the package; and contact Raycus as soon as possible if there are any issues.

Take extra care when removing the unit from the package and make sure that the fiber optic cable stays away from any possible collision and vibration. Please do NOT distort, bend or pull the output cable when unpacking the device; and avoid any collision to the head of laser output.



**CAUTION:** The fiber optic cable and output head are precise optic instrument, ANY vibration or impact to the output head, and twist or excessive bend to the cable will damage the instrument.

## 2.4 Operation Environment

The operation conditions are listed as the following table:

Table 1: The Operation Environment for the Laser

Model	A4000D	A6000D	A8000D	A10000D	A12000D
Supply Voltage(V)	Three-phase four-wire system AC330V~AC420V、50/60Hz (including PE)				
Power supply capacity(KVA)	>20	>30	>40	>50	>60
Installation Environment	Flat, no vibration nor impact				
Ambient Temperature	10℃~40℃				
Relative Humidity	<70%				

Tips: Install the laser in an air-conditioned environment for longer life and better performance.

## 2.5 Attentions

- a) Make sure the product is properly grounded before use.
- b) Make sure that the correct voltage of 380VAC is used. Power supply connection failures will cause irreversible damages the device.
- c) It is important to keep the collimating lens clean, otherwise it will cause irreversible damages the device.
- d) When not using the laser, please cover the fiber delivery cable connector protection cap, do not touch the lens of the output, when necessary, use special dust-free cotton swabs and alcohol to clean the lens.
- e) Please keep the protective cap of fiber delivery cable connector properly when using the laser. To avoid dust, make sure to place the protective cap with the opening facing downward.
- f) High temperature in summer may cause condensation to form inside the laser, which may cause permanent damage to the laser, please ensure that the laser is shut down with the water cooler being stopped at the same time.
- g) low temperatures during the winter can cause the laser's internal cooling water to freeze easily, causing permanent damage to the laser, please ensure that when the laser is in the shutdown state, the water cooler continuous operation.
- h) Failure to follow the instructions may cause laser power loss, and such loss is not covered by warranty.

## 2.6 Specifications

Table 2 Product Specifications

Optical properties						Test Conditions
Model	A4000D	A6000D	A8000D	A10000D	A12000D	
Output power(kW)	4	6	8	10	12	Ambient Temp: 25°C
Operation Mode	CW/Modulated					/
Polarization State	Random					/
Output Power Tunability (%)	10~100					/
Emission Wavelength(nm)	915±10					Nominal Output Power

Output Power Instability	<3%					Nominal Output Power; Duration: 5hrs; Ambient Temp:
Modulation Frequency (Hz)	50~2k					Nominal Output Power
Red Guide Laser Power(mW)	0.5~1					/
Fiber output type	iHQB		QD			/
Fiber core diameter (μm)	600		1000			/
Minimum bending diameter (mm)	400		600			/
Beam divergence half-angle (rad)	≤0.22					Nominal Output Power
Delivery Cable Length(m)	20					Customizable
Electrical characteristic						
Operating Voltage	Three-phase four-wire system AC330V~AC420V、50/60Hz (IncludePE)					/
Maximum power Consumption (kW)	10	15	20	25	30	Nominal Output power
Way to control	RS232/Ethernet/AD					/
Other characteristic						/
Dimension (mm)	662×990×1160	897×968×1159	1199×968×1159			Includes casters and rings, without warning lights
Weight (kg)	<300	<360	<400	<450	<500	Air conditioning included
Operating Ambient Temperature (°C)	10~40					/
Humidity (%)	<70					/
Storage temperature (°C)	-10~60					/
Cooling method	Water cooling					/

### 3 Installation

#### 3.1 Dimensions

The main body dimensions of RFL-A4000D fiber delivered direct diode laser shown in Figure 1.

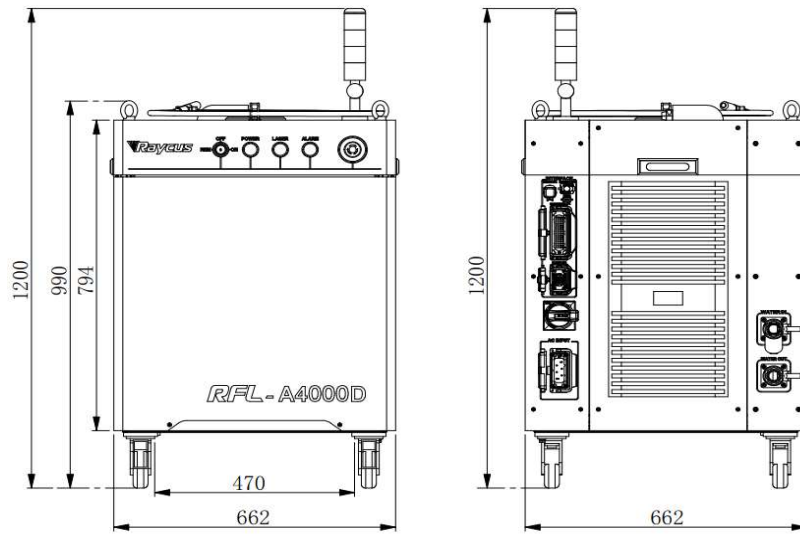

a) Front and rear view of the laser

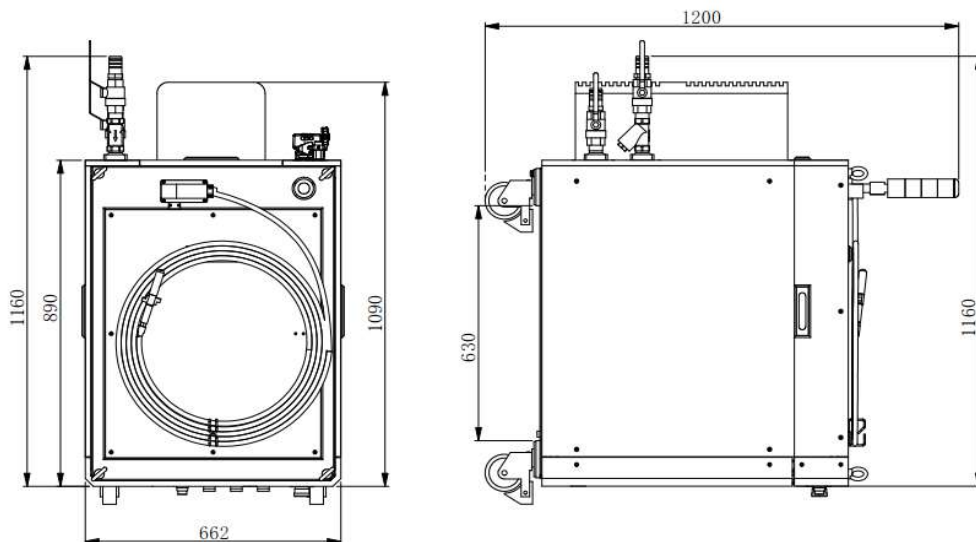

b) Top and left view of the laser

The main body dimensions of RFL-A6000D fiber delivered direct diode laser shown in Figure 2.

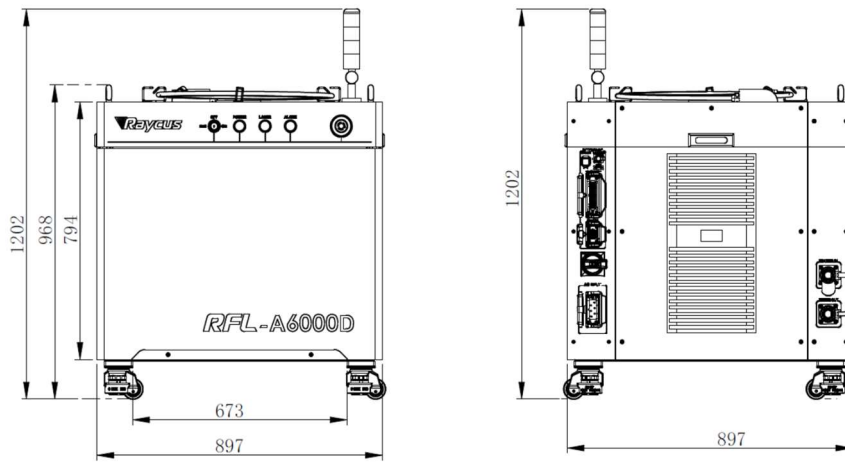

a) Front and rear view of the laser

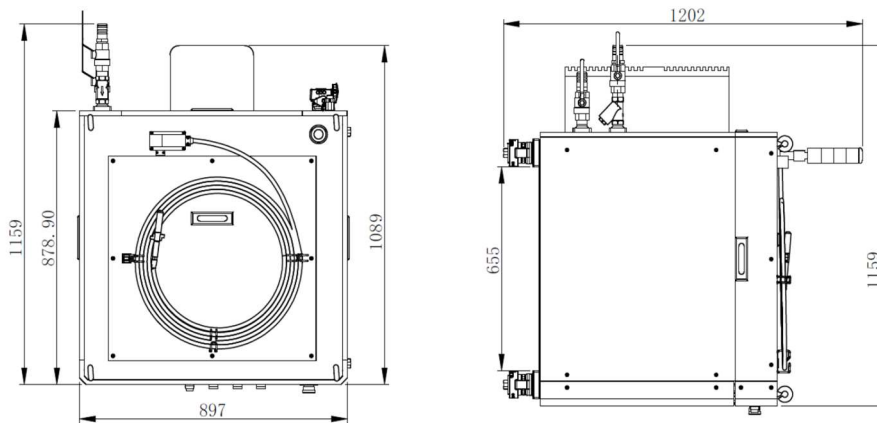

b) Top and left view of the laser

Figure 2 the dimensions of RFL-A6000D fiber delivered direct diode laser

The RFL-A4000D/A6000D fiber delivered direct diode laser uses RFL- iHQB fiber delivery cable, and its form factor is shown in Figure 3.

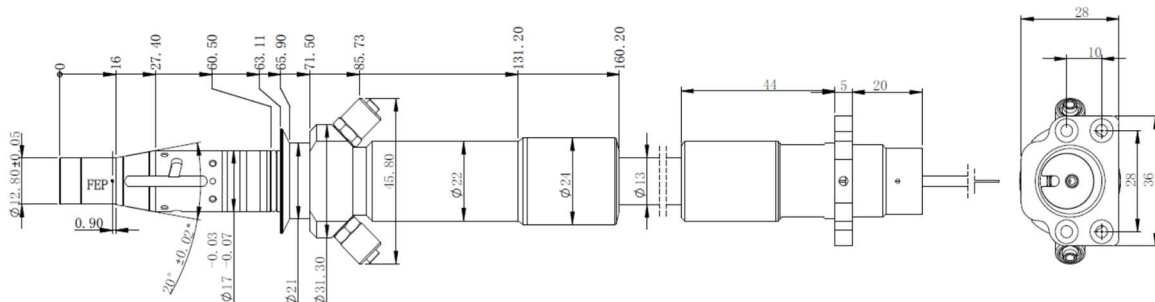
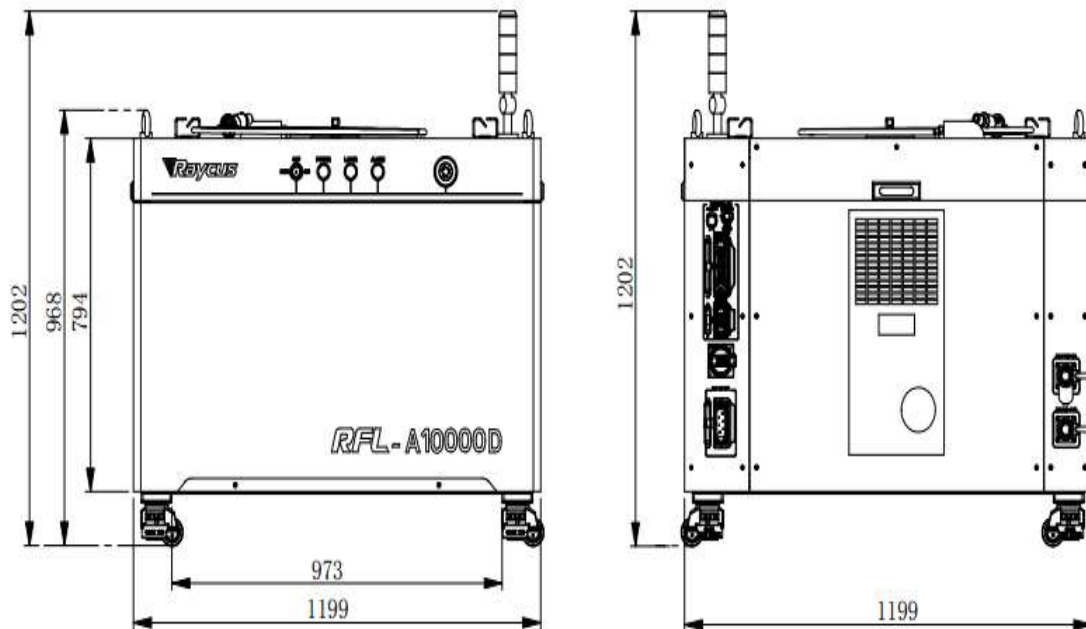
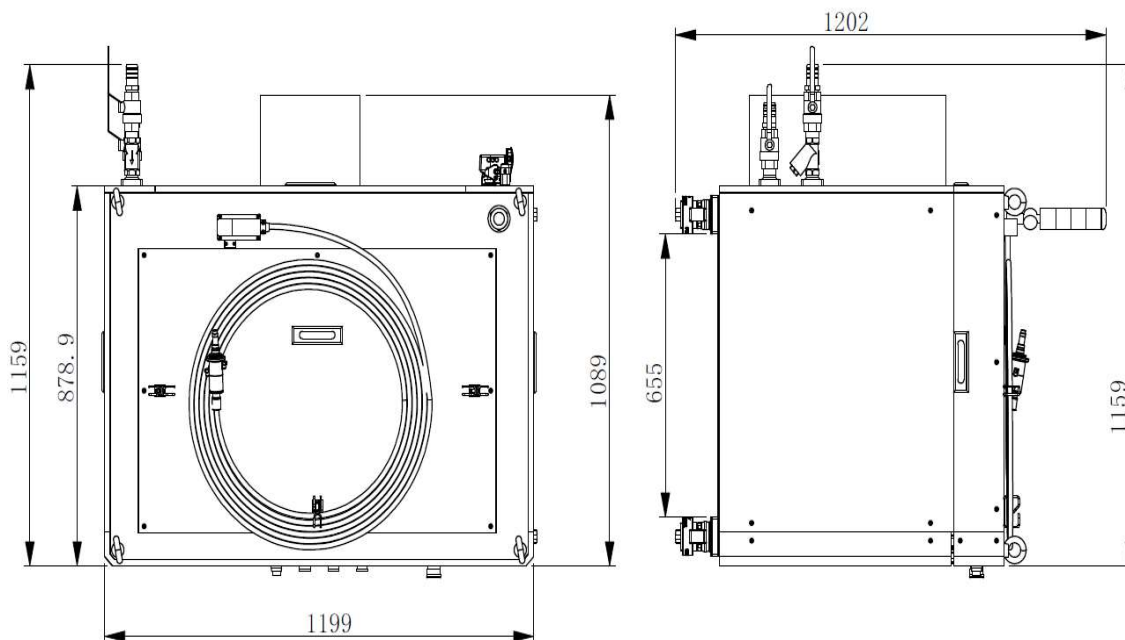

Figure 3 External dimensions of the RFL-iHQB fiber delivery cable connector

The main body dimensions of RFL-A8000D/A10000D/A12000D fiber delivered direct diode laser shown in Figure 4.



a) Front and rear view of the laser



b) Top and left view of the laser

Figure 4 The dimensions of RFL-A8000D/A10000D/A12000D fiber delivered direct diode laser

RFL-A8000D/A10000D/A12000D fiber delivered direct diode laser uses RFL- QD fiber delivery cable, and its form factor is shown in Figure 5

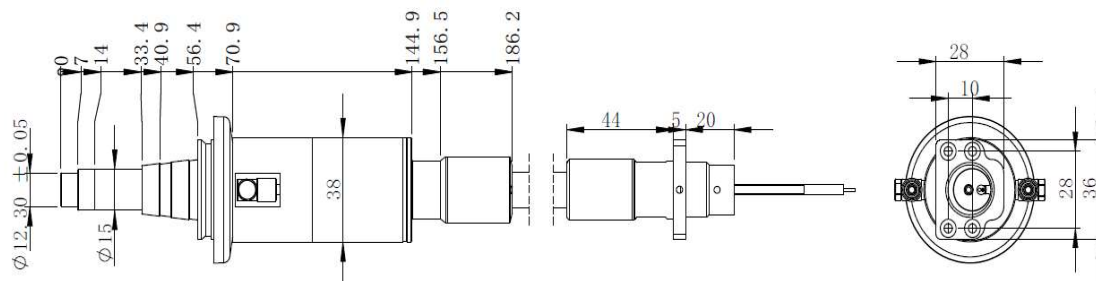

Figure 5 External dimensions of the RFL-QD fiber delivery cable connector

**Note: The dimensions in the above diagram are in the unit of mm.**

Before the laser works, make sure that the two copper contacts (Interlock pins) on the output head are shorted, otherwise the laser will not work properly. Before installing the output cable into the processing head, the lens of the output cable must be inspected. If the output cable lens is dirty, the lens must be cleaned. It is forbidden to disassemble the output lens by anyone other than staffs from Raycus, otherwise the warranty will be invalidated.

### 3.2 Installation rules

- a) Place the laser horizontally in a suitable position and fix it as necessary.
- b) Before the laser is powered on, please check if the power supply has the correct voltage, whether the grounding line is well grounded.
- c) Connect the power cable and control cable to the product when power supply is OFF.
- d) Connect the cooling system to the laser and fiber delivery cable connector according to the water inlet and outlet signs.
- e) Please check the fiber delivery cable connector and make sure to clean it before installing it in the equipment.
- f) Do not step on, squeeze or excessively bend the protective tube during the installation of the fiber delivery cable connector to avoid damage to the optical fiber.
- g) In the process of installing the fiber delivery cable connector, ensure the cleanliness of the surrounding environment (do not use electric fans to dissipate heat when it is hot in summer to avoid large dust in the air).
- h) The minimum bending diameter of the laser transmission cable in non-working conditions such as transportation and storage shall not be less than 40cm.

i) Customers can use the four lifting rings at the top of the product or the four casters at the bottom to lift or move the product. Before lifting the laser source, make sure that the four lifting rings are installed firmly and reliably. When lifting the laser source, be sure to use the four lifting rings; when pushing the laser source, please make sure that the support block at the bottom of the horizontal adjustment caster is off the ground. After the laser source is positioned, adjust the support block to make it contact the ground to avoid displacement of the laser source. As shown in Figure 6.

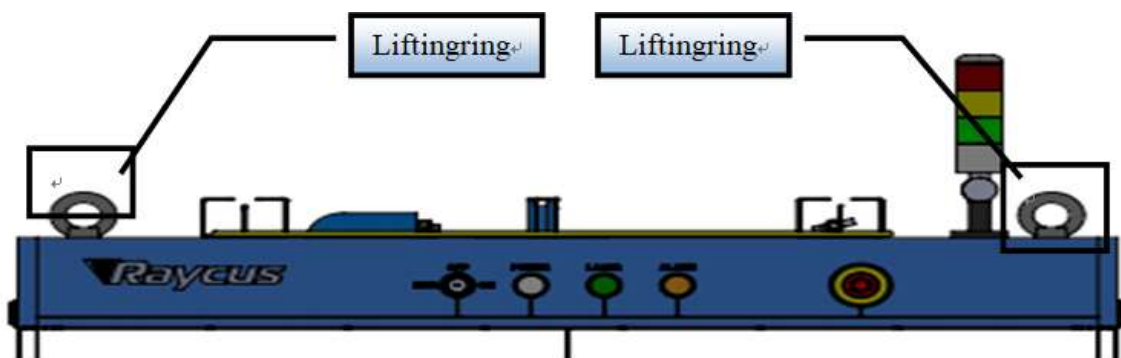

a) Lifting ring

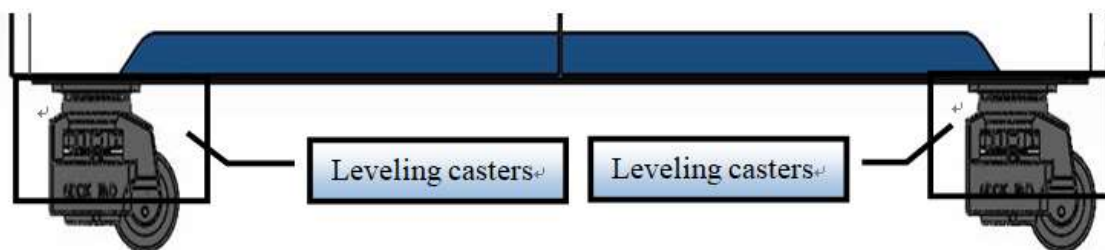

b) Leveling casters

Figure 6 Laser top lifting ring and bottom level adjustment caster

	<p><b>CAUTION:</b> All the cables can only be connected when power supply is off. Hot plug may damage the device.</p>
	<p><b>CAUTION:</b></p> <p>a) The placement of the laser output cable should be as natural as possible, and the output cable should not be twisted.</p> <p>b) If the coil diameter of the fiber delivery cable connector is too small, it will damage the laser.</p>

**CAUTION:**

- a) During the process of installation and disassembly, please handle the fiber delivery cable connector gently, and avoid vibration.
- b) Before assembling the laser output head, ensure that the optical lens and cutting head cavity are clean and free of pollution.

### 3.3 Cooling Requirements

Table 3 Cooling Requirements

Model	Cooling Capacity (kW)	Minimum Flow (L/min)	Input Pressure (Bar)	Hose inner Diameter (mm)	Cooling water Temperature (°C)
RFL-A4000D	≥6	>42	4~6	Φ25	25±0.5
RFL-A6000D	≥9	>50			
RFL-A8000D	≥12	>62		Φ32	
RFL-A10000D	≥15	>78			
RFL-A12000D	≥18	>92			

#### Requirements of Cooling Water:

- a) Cooling water needs to be pure water.
- b) In order to prevent the water in the water cooler from growing mold and causing pipeline blockage, it is recommended to add alcohol when filling pure water, and the amount of alcohol added is 10% of pure water.
- c) When the ambient temperature of the equipment is between -10 °C and 0 °C, the glycol solution with a volume ratio of 30% must be used and replaced it every 2 months.
- d) If ambient temperature is below -10°C, the chiller with both heating and cooling functions must be used and kept in full-time operation.

#### Water cooling requirements for output optical cables:

- a) Water flow requirements: iHQB fiber delivery cable connector water flow rate greater than 1.5L/min; QD fiber delivery cable connector water flow rate greater than 2.5L/min.
- b) Water cooling pressure: 4~6 Bar at the water inlet.
- c) Water inlet and outlet connector type: iHQB output fiber optic cable φ6 quick release connector; QD output fiber optic cable φ8 quick release connector.

- d) Water pipe type: iHQB fiber delivery cable connector outer diameter  $\phi 6$  inner diameter  $\phi 4$ ; QD fiber delivery cable connector outer diameter  $\phi 8$  inner diameter  $\phi 5.5$ .
- e) Cooling water quality: deionized water, distilled water, purified water; it is recommended to replace the water once a month, and the replacement period should not exceed two months.
- f) PH value of cooling water: 5.5~9.
- g) The water cooler needs to be equipped with a filter element whose filter particle size is less than 100um; the filter element needs to be cleaned once a month.
- h) Maximum cooling water temperature: 35°C.
- i) The lowest cooling water temperature: 5°C greater than the saturated dew point temperature.
- j) Additives in cooling water: meet the above PH value and solid particle size requirements.

**Other requirements:**

- a) When starting the cooling system for the first time, check the entire water system and joint for water leakage.
- b) If the laser is not used for a long time, the cooling water inside the cooling system and the laser inside should be drained, otherwise the laser equipment will be damaged.
- c) Please use compressed gas below 0.5MPa when emptying water from the device. Failure to do so may cause permanent equipment damage to cooling system.

	<p><b>CAUTION:</b></p> <ul style="list-style-type: none"> <li>a) Set the water temperature of the cooling system correctly according to the ambient temperature. Setting the water temperature too high will result in the laser not working properly. Setting the water temperature too low will cause condensation inside the laser or the laser output head, which will cause damage to the laser.</li> <li>b) Before turning on the laser, the cooling system must be working properly, and the water temperature should be suitable for the temperature.</li> </ul>
---	--

#### 4 Using the Product



Please log in to the official website of Raycus to download the new PC software and the PC software user manual. Website: <http://www.raycuslaser.com>

## 4.1 Front Panel

Figure 7 shows the front panel.

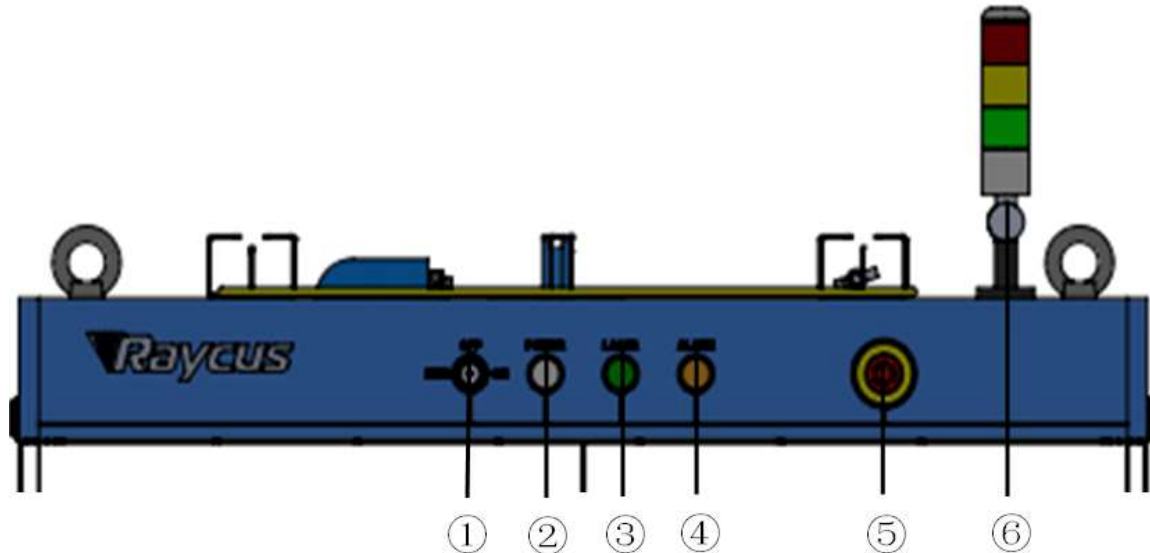

Figure 7 Front view of the panel

**REM/OFF/ON:** The key switch is the main control switch of the laser. Insert the key and turn it to the "ON" position, the main control part of the laser is powered on, and the POWER light is on, Rotate to the "REM" position, you need to close the Pin8 and Pin9 of the XP1 interface on the rear panel to achieve remote power-on, and rotate to REM to activate the hard-wired control mode of the laser.

**POWER:** Control power indicator, when the white indicator light is on, it means the main control system is on.

**LASER:** The power button of the laser main power supply has a green light indicator function. After the laser main control system is powered on and all INTERLOCKS are detected as normal, press this button, the laser main power supply is powered on, and the button lights up after the main power supply is powered on.

**ALARM:** INTERLOCK alarm indication, the ALARM indicator lights up during the power-on self-check on the control panel. After the self-inspection is completed, all INTERLOCK interfaces are normally closed, and the ALARM indicator is off. During the operation of the laser, any INTERLOCK failure will cause the indicator to light.

**STOP:** Emergency stop button, press it to turn off the laser immediately; turn clockwise to release the button. Use the key to turn on the laser and power on the laser again to return to normal.

**INDICATOR LIGHT:** After the main power supply of the laser is turned on, the green indicator light is on when the laser is Ready; when the laser is emitting light, the red indicator light is on; when the laser has a fault, the yellow indicator light is on, accompanied by an alarm sound.

## 4.2 Rear Panel

Figure 8 shows the rear panel.

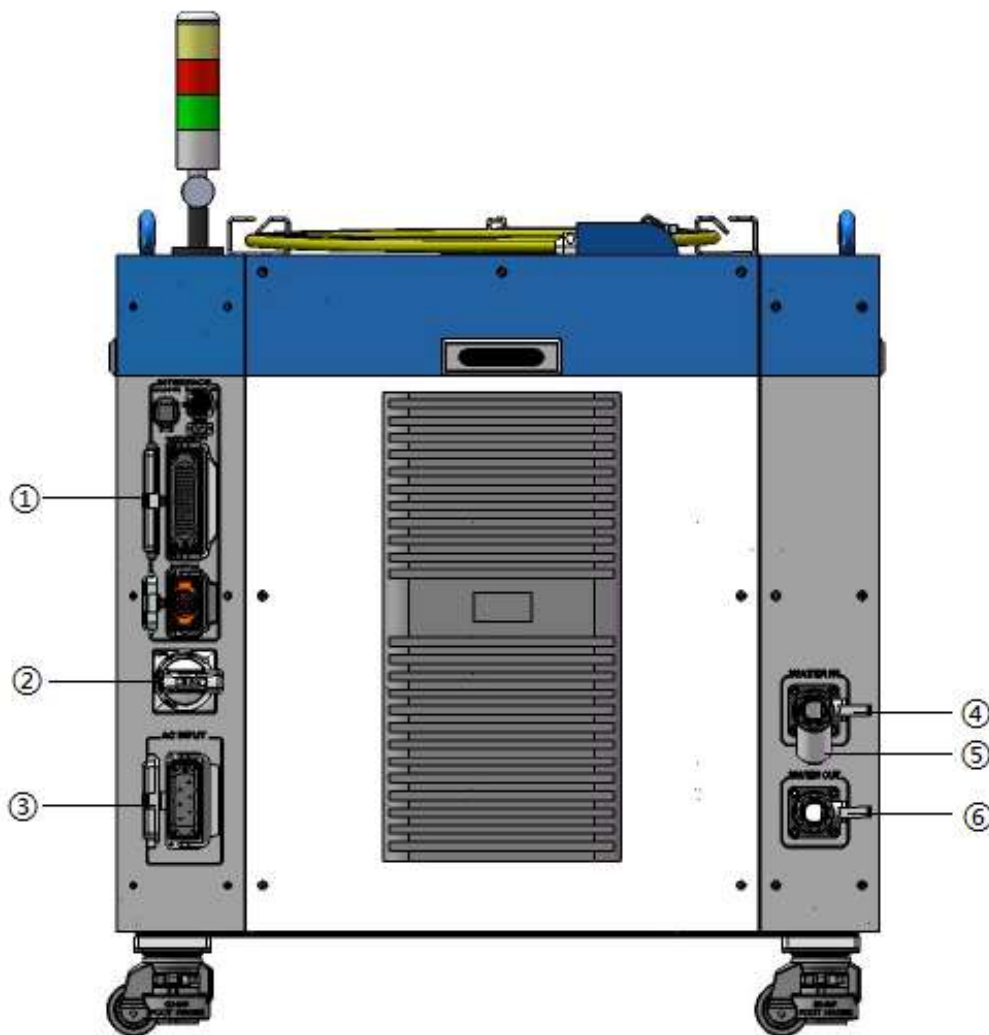

Figure 8 Rear view of product panel

①**INTERFACE:** this interface provides all control signals, including: RS232 communication, laser on/off control, laser remote control mode selection, analog control, modulation signal, Interlock interface, etc. Refer to Table 4 for the definition of control lines. This socket comes with a protective cover and a

lock. When you are not using the product, you can cover the power input socket with the protective cover and lock it with the lock.

②**BREAKER:** the circuit breaker (air switch) on the rear panel of the laser is the main power switch of the laser.

③**AC INPUT:** the power input socket must be matched with the plug provided by us. This socket comes with a protective cover and a lock. When you are not using the product, you can cover the power input socket with the protective cover and lock it with the lock.

④**WATER IN:** The water inlet of the laser, this interface is connected to the water outlet of the cooling water of the water cooler.

⑤**Filter:** filter the cooling water into the laser.

⑥**WATER OUT:** The water outlet of the laser, this interface is connected to the water inlet of the cooling water of the water cooler.

### 4.3 Power Connection

	<p><b>CAUTION:</b></p> <p>a) Before connecting to the AC power supply, please check whether the supplied AC power supply meets the requirements in Table 1;</p> <p>b) Incorrect wiring will cause damage to the laser, so please check whether the power cord is connected correctly before powering on the laser.</p>
---	--

Figure 9 shows the power cord provided by Raycus.



Figure 9 Laser source power cord

Insert the plug at the end of the power cord into the socket marked "AC INPUT" on the rear panel. Note that the plug has an anti-reverse connection function. After inserting it, use the lock to lock. The plug and socket as shown in Figure 10.



Figure10 physical picture of power cord plugs and socket

The definition and parameter requirements of the AC input line interface are shown in Table 4.

Table 4 AC input line interface definition and parameter requirements

4kW/6kW laser AC input line interface definition and parameter requirements					
Connector Tag	Interface definition	Logo	Wire diameter	Wire color	Wire length
1	AC380V-L1	L1	4mm <sup>2</sup>	Brown	15m
3	AC380V-L2	L2	4mm <sup>2</sup>	Black	15m
5	AC380V-L3	L3	4mm <sup>2</sup>	Gray	15m
PE	Protective	PE	4mm <sup>2</sup>	Yellow green	15m
8~12kW laser AC input line interface definition and parameter requirements					
Connector tag	Interface definition	Logo	Wire diameter	wire color	Wire length
1、2	AC380V-L1	L1	6mm <sup>2</sup> +6mm <sup>2</sup>	Brown	15m
3、4	AC380V-L2	L2	6mm <sup>2</sup> +6mm <sup>2</sup>	Black	15m
5、6	AC380V-L3	L3	6mm <sup>2</sup> +6mm <sup>2</sup>	Grey	15m
PE	protective	PE	6mm <sup>2</sup>	Yellow green	15m

#### 4.4 Control Interface Definition

This type of laser does not provide a control signal line, only a control signal connector. The appearance of the joint is shown in Figure 11.

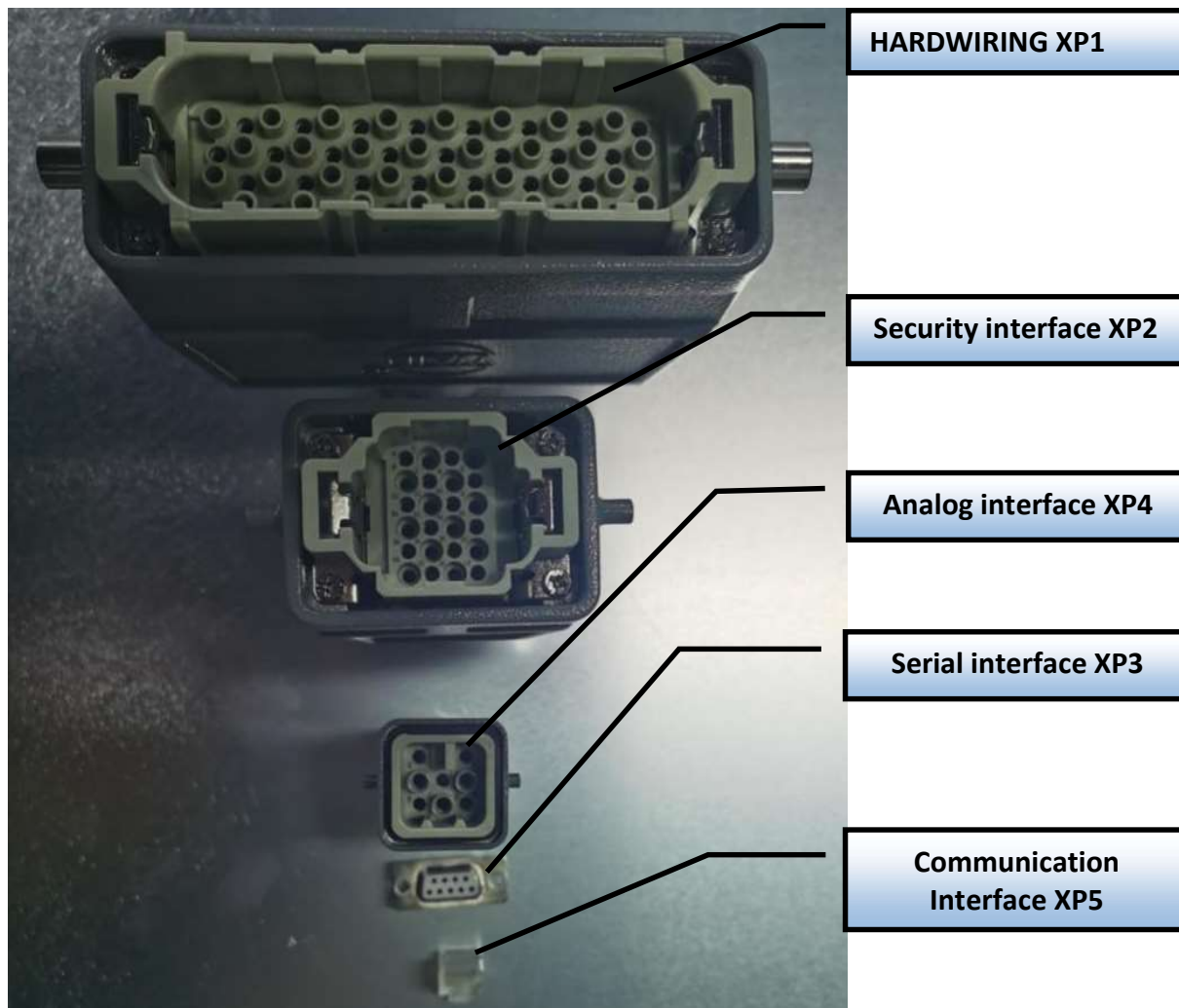

Figure 11 Control signal line

##### 4.4.1 Safety XP2 Interface

24-pin safety interface, with functions such as safety interlock, remote control system power-on, remote main power power-on, light output control, etc. It also contains output signals such as laser system power-on indication, main power power-on indication, and light output indication, detailed The interface definition is shown in Table 5.

Table 5 XP2 security interface definition

Pin Number	Type	Description
1	MOD+	Light control, voltage input signal laser ON: 4~30V; Laser OFF: -3~2V
2	MOD-	Maximum modulation frequency 2kHz
3	OUT (FET S pole)	Laser output indication, MOS pipe D、S output The light-emitting MOS pipe is turned on
4	OUT(FET D pole)	The light-emitting MOS pipe is turned off, current<0.5A,Votage<30V
5	OUT	Light warning light negative, current<100mA
6	OUT	Main power on alarm light negative, current<100mA
7	OUT (24V)	Output light and main power on alarm light positive, current<400mA
8	IN	Remote main control board power on, cannot be external voltage or ground. When pin 8 and 9 are closed, the main control board is powered on, the main control board is powered off when 8 and 9 feet are closed.
9	IN	
10	OUT (24V)	Output light and main power on alarm light positive, current<400mA
11	OUT	Front panel emergency output 1, relay contact output, passive contact current <100 mA, voltage<30V The current panel stop press ,11,14 open, or short circuit
14	OUT	
12	OUT	Front panel emergency output 2, relay contact output, passive contact current <100 mA, voltage<30V The current panel stop press ,12,13 open, or short circuit
13	OUT	
15	OUT (FET S pole)	Main power supply power on output indication, MOS pipe D、S output The MOS pipe is turned on when the main power is turned on The MOS pipe is turned off when the main power is turned off current<0.5A,voltage<30V
16	OUT(FET D pole)	
17	IN	Interlock1 import, Active contacts, Normal short connection 17、20, no external voltage or grounding
20	IN	
18	IN	Interlock2 import, Active contacts Normal short connection18、19, no external voltage or grounding
19	IN	
21	IN	Remote main power supply power up, the Power button function on thefront panel is the same, when the 21,22 feet closed, start the main power supply, active contact, no external voltage or grounding.
22	IN	
23	OUT	The laser has been powered on and output Disconnected - laser key switch is in the OFF position
24	OUT	Closed - laser key switch is in ON or REM position External voltage signal, currnet<0.5A,voltage<30V

MOD signal is 5 and 24V compatible, and reverse connection is not allowed. MOD is used to control the laser output and off when the key switch is hit ON and the laser is working out of light external control mode. When the key switch hits REM, and the laser is operating in outgoing light control mode, MOD and XP1-A2 (at this time, the A2 bit outgoing light enable signal) are jointly used to control the laser output and off. and the internal circuit diagram is shown in Figures 12.

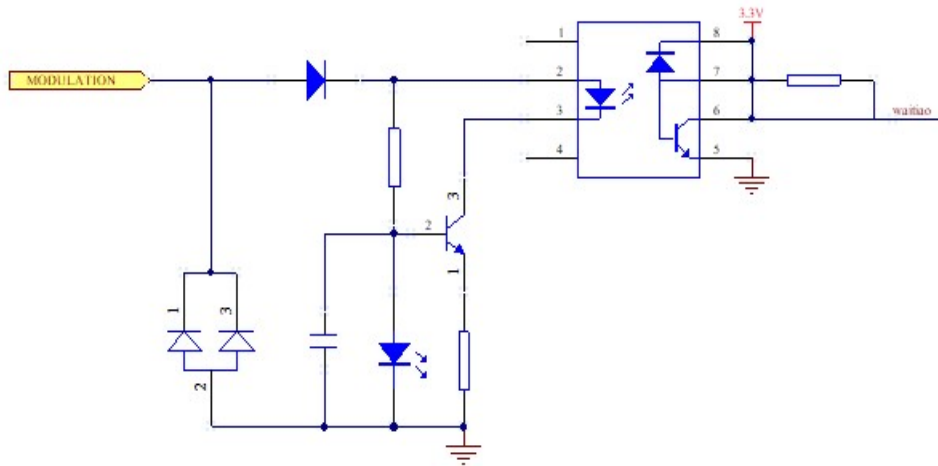

Figure 12 MOD Signal Circuit Diagram

XP2's A3-A4 light output indication, A15-A16 is the main power has been powered on output indication, The internal circuit diagram is shown in Figure 13, and the recommended customer wiring diagrams are shown in Figures 14 and 15.

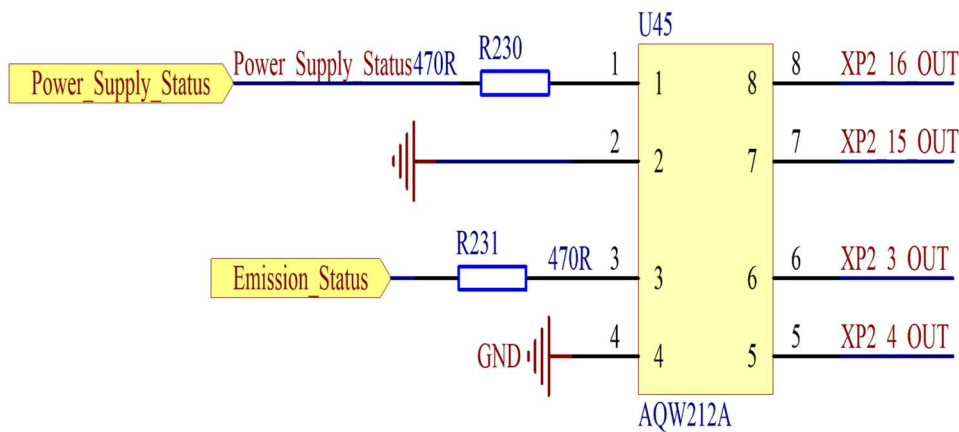

Figure13 Out light output and main power up indication circuit diagram

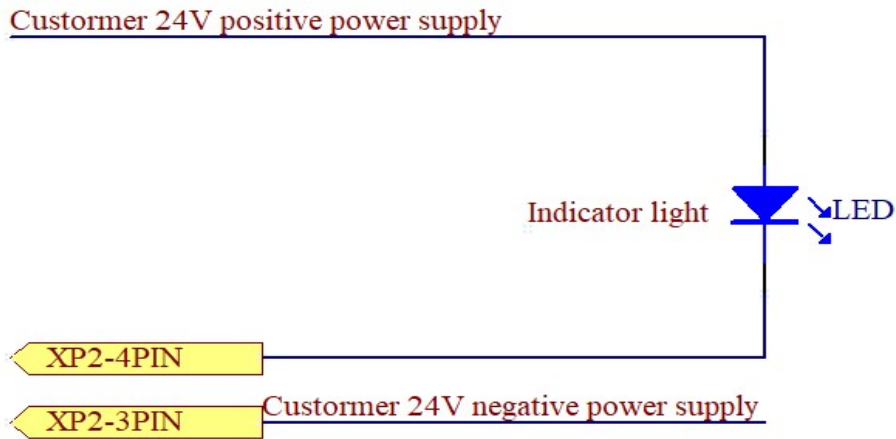

Figure14 Recommended wiring diagram for light output indication

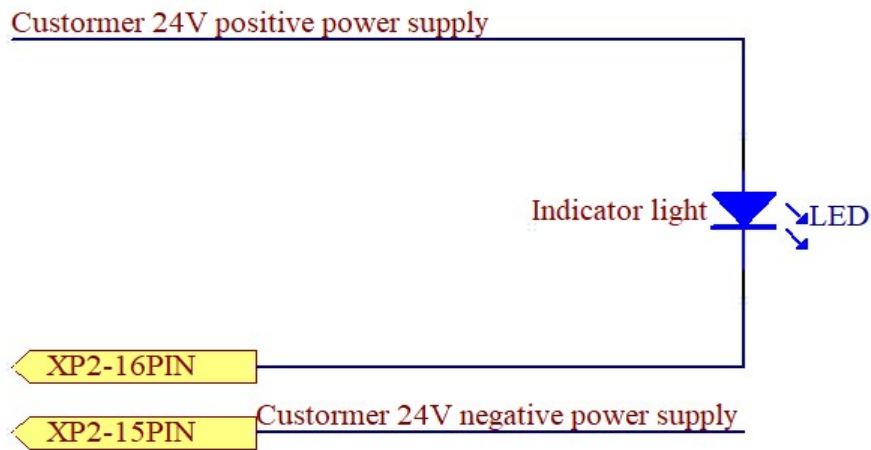

Figure 15 Recommended wiring diagram for main power up indication

Active light out warning indication and main power supply has been powered on warning. indication, the internal circuit diagram is shown in Figure 16 and the recommended customer wiring diagram is shown in Figure 17.

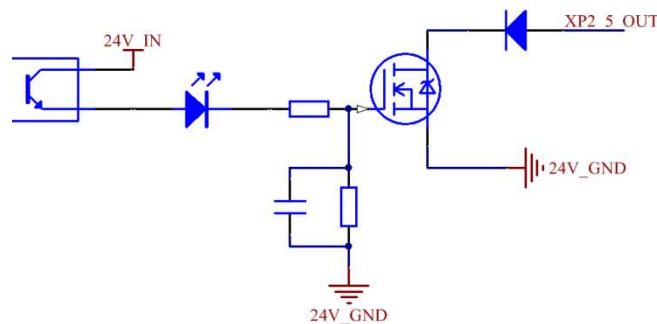

Figure 16 Active light out indication and main power supply has been powered on indication circuit diagram

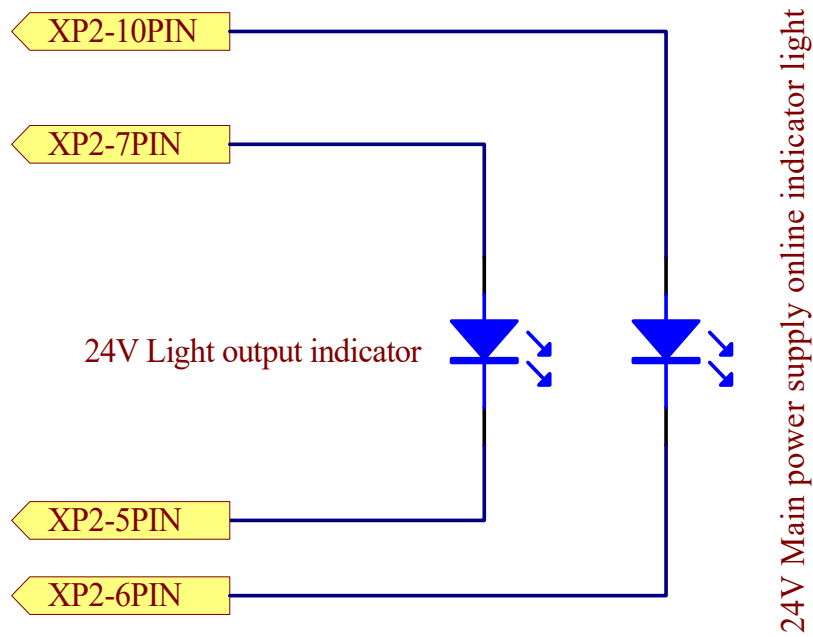

Figure 17 Active light indication and main power supply has been powered on the recommended wiring diagram

The recommended customer wiring diagram for the remote master board power up is shown in Figure 18. When the laser key switch hits REM mode, XP2-8、9 must be shorted to the main control board to power up.

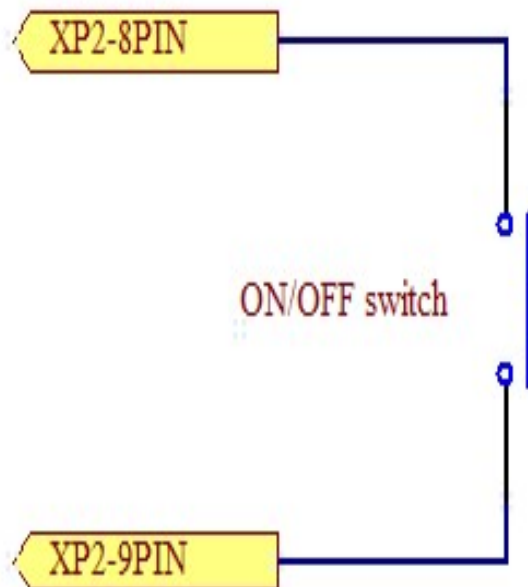

Figure 18 Remote control board power-up recommended wiring diagram

Remote main power up signal is used to enable mains power-up via the XP2 interface. the recommended customer wiring diagram is shown in Figure 19.

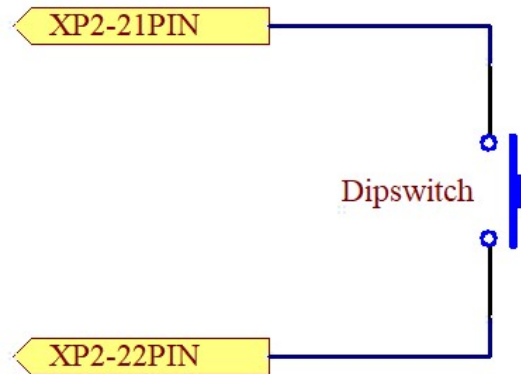

Figure 19 XP2 remote main power up wiring diagram

#### 4.4.2 Hard Wiring XP1

64 pin hardwire interface, control signal input and output interface of laser in remote mode. Input high level is greater than 18V valid, input low level is less than 3V valid. Specific interface definitions are shown in Table 6 below.

Table 6 XP1 Hardwire interface definitions

Interface requirements		Type	Description
Pin number	Pin definition		
A1	Laser request signal	Input signal	request laser, this bit is valid before the laser receives other instructions
A2	Programming Mode start-up execution	Input signal	Import signal, rising edge start according to the pre-downloaded programming instructions output laser; program number is determined by the A8~A14. The laser power is set by AD analog if the program number is 0000000 and the A6 is high; if the program number is 0000000 and the A6 is low, the laser power is set by the host computer; if the program number is 0000000 and the A6 is low, the A3 is high, and the output is controlled by the host computer software.
A3	Enabling Internal patterns	Input signal	High level enables PC software control function.
A4	Reset signal	Input signal	High level effective, clear laser alarm bit, effective high-level time at least 1 MS.
A5	Red light indicator	Input signal	The effective red light indicates light.
A6	Simulation control enabling energy	Input signal	Enable analog input signal after valid(Program num = 0000000)
A7	Stop programming Mode	Input signal	Stop programming mode at high power

A8	Program Num 0	Input signal	Low position
A9~A14	Program Num 1~6	Input signal	High 1~6 bits , select program number
A15	Synchronous input	Input signal	Backup
A16	COM		Reference ground for all signals
C1	Laser-driven power supply	Input signal	Input signal, up edge starts main power supply, down edge turns off main power supply
C2	Back up	-	-
C3~C6	Back up	-	-
C7	Back up	-	-
C8~C16	Back up	-	-
B1	The laser is ready	Output signal	Indicating that the laser is ready to produce light
B2	Laser output	Output signal	Indicating that the laser is emitting light
B3	The laser Operates in internal mode	Output signal	Indicating that the laser operates in internal mode
B4	Laser anomalies	Output signal	Indicating abnormal laser
B5	Laser red light indication	Output signal	Indicating that the laser is emitting red
B6	AD mode	Output signal	Indicating that the laser operates in AD mode
B7	Laser received request signal	Output signal	Indicating that the laser receives a request signal(A1)
B8	Main power supply in laser	Output signal	Indicating that the main power supply of the laser is powered on
B9	The laser is operating in programming mode	Output signal	Indicating that the laser is performing programming mode
B10	Programming mode execution completed	Output signal	Indicating that the laser programming mode is completed, the bit clears when the A2 is invalid
B11	Abnormal Wave Mode Termination	Output signal	Indicating that the laser programming mode is abnormally terminated ,RESET (A4) cleared
B12	Synchronous output	Output signal	High effective, low invalid

B13	Warning output	Output signal	Indicating that the laser has a warning
B14	Backup	-	-
B15	External power supply positive	-	External 24V input voltage, the power supply of all output signals in the table, only the two pins are connected to the 24V power output signal to be effective.
B16	Negative external power	-	
D1~D4	Backup	-	-
D5	Water cooler warning output	Output signal	Current water temperature warning
D6	Water cooler alarm output	Output signal	Current water temperature alarm
D7	Back up	-	-
D8~D11	Laser hardware address	Output signal	Coding-Cable function ;0000-0 laser ,0001-1 laser; D8 low, D11 high
D12~D16	Backup	-	-

#### 4.4.3 RS232 XP3 Interface

The 9-pin serial interface is used for the communication between the laser and the upper computer. It can be used to communicate with the upper computer of Raycus Company or the software of the upper computer which integrates the communication protocol of Raycus. The definitions are shown in Table 7 below.

Table 7 XP3 Serial Interface Definitions

Pin No	Type	Description
2	IN	RXD, the serial port receive pin of the laser
3	OUT	TXD, the serial port transmit pin of the laser
5	COM	GND, serial port public ground

#### 4.4.4 Analog Interface XP4

The analog interface, an 8-core Harting interface, is used to control the output power of the laser by analog in AD mode and can also monitor the output light and power feedback signals of the laser. The interface definition is shown in Table 8 below.

Table 8 XP4 Analog interface definitions

Pin No	Type	Description
1	IN	0~10 V analog signal, laser power control signal in AD mode, 0~10 V corresponding to 0~100% output power
2	AGND	Pin 1's reference
3	OUT	Optical power monitoring output, 0V corresponds to 0% laser power output, 8V corresponds to 100% laser power output
4	Reference	Pin 3's Reference
5	N/C	Back up
6	N/C	Back up
7,8	N/C	Back up

#### 4.4.5 INTERNET Interface XP5

Table 9 XP5 Communication interface definitions

Pin	Function	Description
1	TX+	Date transmission+
2	TX-	Date transmission-
3	RX+	Date Receive+
4	N/C	-
5	N/C	-
6	RX-	Date Receive-
7	N/C	-
8	N/C	-

#### 4.5 Introduction to Safety Interlock

Raycus' product is designed with a safe interlocking loop, which is a two-channel system with output monitoring and manual reset. When the safety interlocking circuit is open, the safety circuit will disconnect the working power of the optical module, that is, the main power supply of the optical module.

To start the main power supply, you must close the two interlocking channels (24 pin interface :17 and 20 feet short ,18 and 19 feet short). Otherwise, the main power will be turned off and the laser cannot be turned on. When one of the channels is open, the laser main power supply is impossible to start until the other channel is open, and then the two channels are closed before the laser main power supply can be started.

If the interlock is closed (the stop button is also released) and there is no error alarm, press the start (LASER) button to start the main power supply, and the ‘main power has been started’ pin of the external interface will have a high-level output.

When the security interlocking circuit is open or the error is detected, the main power supply of the optical module will be turned off, and the ‘main power supply has been started’ signal of the interface will become low level. The detected ‘error state’ is latched and the on-board relay opens the manual reset loop with monitoring until the error is cleared, thus preventing the laser from being restarted. If errors such as short circuit between interlocking channels or short circuit of start (LASER) button are detected, the safety loop cannot be reset before the error is cleared.

#### **4.6 Schematic diagram of the internal electrical circuit of the laser**

The internal electrical circuit of the laser is shown in figure 20.

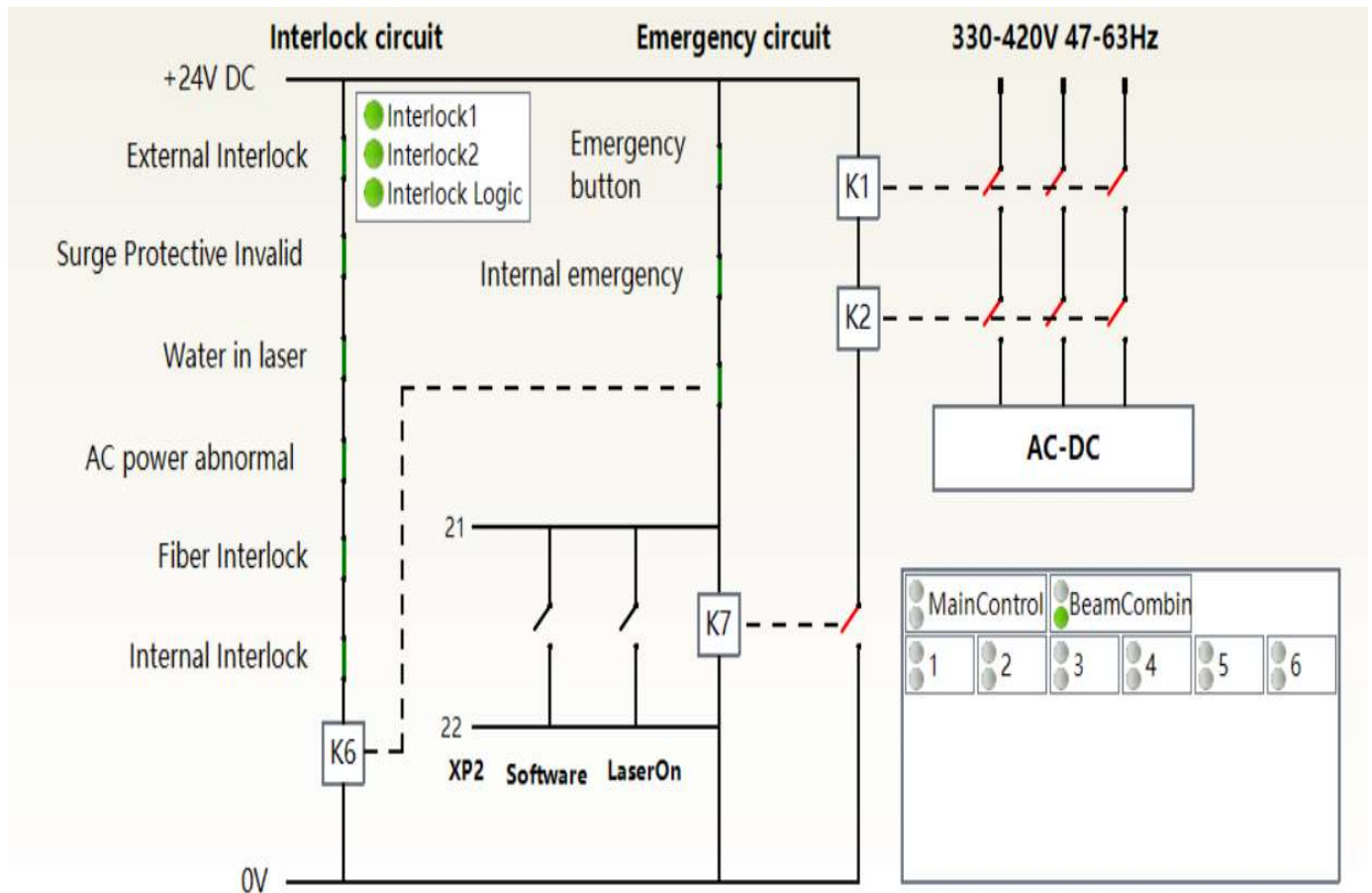

Figure 20 Schematic diagram of the internal electrical circuit of the laser

#### 4.7 Start operation sequence.

- Turn on the water cooler and check if the water pipe is leaking. If there is no water leakage, turn off the water cooler and make electrical connections.
- Make sure the circuit breaker is in an OFF state and the stop button on the front panel of the laser EMERGENCY STOP pressed; all electrical connections must be completed before the laser is powered on.
- Confirm that the three-phase electrical connection is correct, and the power supply meets the specifications of the power supply. Turn on the water cooler.
- Close the rear panel circuit breaker, release the laser front panel emergency stop switch; Ensure that all laser doors are closed, optical cable output head has been inserted into the welding head (or corresponding equipment), all interlock interfaces have been closed.

- e) Select the required control mode according to 1.4 control mode, turn on the key switch, and start the main power supply waiting for the laser to Ready. When the laser Ready, the green light comes in the tricolor above the machine, representing that the laser can light.

## 5 Control Mode Selection

Raycus high-power continuous wave laser has two control modes: respectively ON mode and REM mode, the user can select mode that needs to enter through the key to the front panel.

Table 10 Function of REM mode and ON mode

	AD mode	Emission control	Programming mode	Power	Emission and closing of the laser	Red-light
ON mode	close①	close②	-	communication⑬	communication⑪	communication⑫
	enable③	close②	-	XP4-1、2pin pressure	communication⑪	communication⑫
	close①	enable④	-	communication⑬	XP2-1、2pin level	communication⑫
	enable③	enable④	-	XP4-1、2pin pressure	XP2-1、2pin level	communication⑫
REM mode	close⑤	close⑥	close⑦	communication⑬	communication⑪	communication⑫
	enable⑧	close⑥	close⑦	XP4-1、2pin pressure	communication⑪	XP1-A1、A5 is high level
	close⑤	enable⑨	close⑦	communication⑬	XP1-A1 laser request is high. XP1-A2 laser light output enable is high. XP2-1,2 input MOD signal	XP1-A1、A5 is high level
	enable⑧	enable⑨	close⑦	XP4-1、2pin pressure	XP1-A1 laser request is high. XP1-A2 laser light output enable is high. XP2-1,2input MOD signal	XP1-A1、A5 is high level
	close⑤	enable⑨	enable⑩	determined by programming command	XP1-A1 laser request is high. XP1-A2 high level indicates operating programs	XP1-A1、A5 is high level

①Communication sends “DEC”, or computer software clicks  button;

②Communication sends “DLE”, or computer software clicks  button;

③Communication sends “EEC”, or computer software clicks  button;

④Communication sends “ELE”, or computer software clicks  button;

⑤XP1-A1is high level, XP1-A6 is low level or suspending;

⑥XP1-A1is high level, XP1-A3is high level;

⑦XP1-A1is high level, XP1-A8~A14 is low level or suspending;

⑧XP1-A1is high level, XP1-A6is high level

⑨XP1-A1is high level, XP1-A3 is low level or suspending;

⑩XP1-A1is high level, XP1-A8~A14 is not all low level;

⑪Emit laser: Communication sends “EMON” or computer software clicks  button.

Turn off the laser: communication sends “EMOFF”, or computer software clicks  button.

⑫Communication sends “ABN” or computer software clicks  button to emit red light,

communication sends “ABF” or computer software clicks  button to turn off the red light.

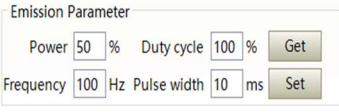
⑬The communication sends "SDC XX" to set the power percentage, XX represents the power percentage, or the computer software clicks  button.

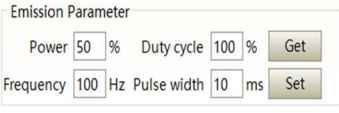

## 5.1 ON Mode

In the ON mode, the user can send commands to set different working modes through computer software or direct communication. After the laser is powered on again, the mode before power failure will be memorized.

### 5.1.1 AD Enable Mode

When AD mode is enabled, the laser power is determined by the analog voltage of pin 1 and pin 2 of XP4; if the AD mode is not enabled, the laser power can be set through the computer software or send the "SDC XX" command.

### 5.1.2 Emission External Control Enable

When the external control is enabled, the laser emission is determined by the MOD level state on the pin 1 and pin 2 of XP2; If the external control emission is not enabled, the laser emission and shutdown are determined by the light output button of the computer software, or communication sends "EMON" to control the laser emission and send "EMOFF" to control the laser off.



### 5.1.3 Red Light Control

In the ON mode, the red light can only be turned on by sending "ABN" through the computer software or communication, and "ABF" turns off red light. The red-light module in the laser works by means of communication, so there is a time delay of at least 10 MS when the red light is turned on and off. When the red light is on, the laser cannot be set to Ready position. Only when the red light is off, can the laser be ready.

### 5.1.4 Programming Mode

In the ON mode, when the current program number of the laser is not 0, the laser will run in the programming mode.

Please use the computer software of Raycus to edit the wave and select the pre-operation program number.

When the laser is in the emission internal control mode, press  or send EMON command, the laser starts to operate program; send or press EMOFF,  the laser can stop program at any time;

When the laser is in the external control mode, the rising edge of MOD starts to operate the program, and the falling edge of MOD can terminate the program at any time.

## **5.2 REM mode**

### **5.2.1AD enable mode**

When both A1 and A6 of XP1 are set high, the laser operates in AD mode, and the current laser power is determined by the analog voltage of pin 1 and pin 2 of XP4; When A6 of XP1 is set low or suspended, the current laser power is set by sending "SDC XX" command through PC software or communication.

### **5.2.2Emission external control**

When both A1 and A3 of XP1 are set high, the laser is in the internal control mode, and the light output is controlled by the computer software's light on button or by communication sending "EMON" to control the light output, and "EMOFF" to control the light off; When A1 of XP1 is set high, A3 is suspended or set low, the laser is in the external control mode, and the output light is determined by the high and low levels of A2, XP2-1 and pin 2 MOD signals of xP1.

### **5.2.3Red light control**

When both A1 and A3 of xP1 are set high, the laser is in the red light internal control mode, and the red light is controlled by the computer software red light button or communication to send "ABN" and "ABF" used to control the ON and OFF of the red light; When A1 of XP1 is set high, A3 is suspended or set low, the laser is in external control mode, and the red light is controlled by A5 ofXP1.

The red-light module in the laser works by means of communication, so there is a time delay of at least 10 MS when the red light is turned on and off.

When the red light is on, the laser cannot be set to ready. Only when the red light is off, can the laser be ready.

### **5.2.4Programming mode**

When A1 of XP1 is set high and A8-A14 is not 0, the laser is in programming mode. At this time, the output light of the laser is controlled by A2 of XP1, and the output wave of the laser is determined by the edited wave.

## 6 Wiring diagram and operation steps

### 6.1 Internal control in ON mode

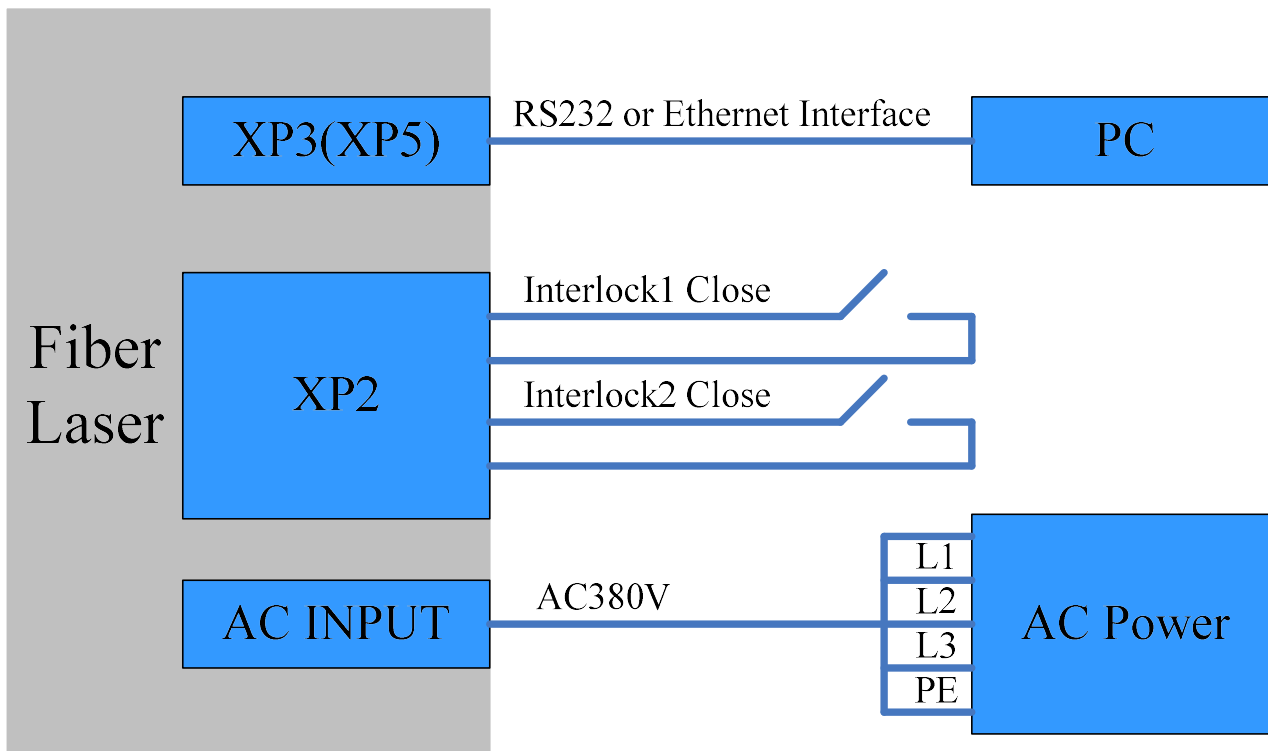

Figure 21 wiring diagram of “ON” mode

Operation methods:

- a) The rear panel air switch hits ON to supply power to the laser.
- b) The front panel key switch is turned ON to put the laser into ON mode.
- c) Open the upper computer software.
- d) Hit the red ON button to view the red light.
- e) Turn off the AD mode, turn off the external control mode. (this mode can be remembered when the power is off)
- f) Click the main power ON button in the upper computer software to turn on the main power.
- g) Wait for the laser tricolor light green light on, the laser ready to work completed.
- h) Set the light output parameters.
- i) Click the ON button in the software of the host computer to turn on the main power supply.
- j) Check the red light of the laser tricolor lamp is on and the laser is outputting light.

## 6.2 Emission external control mode set by power communication in ON mode

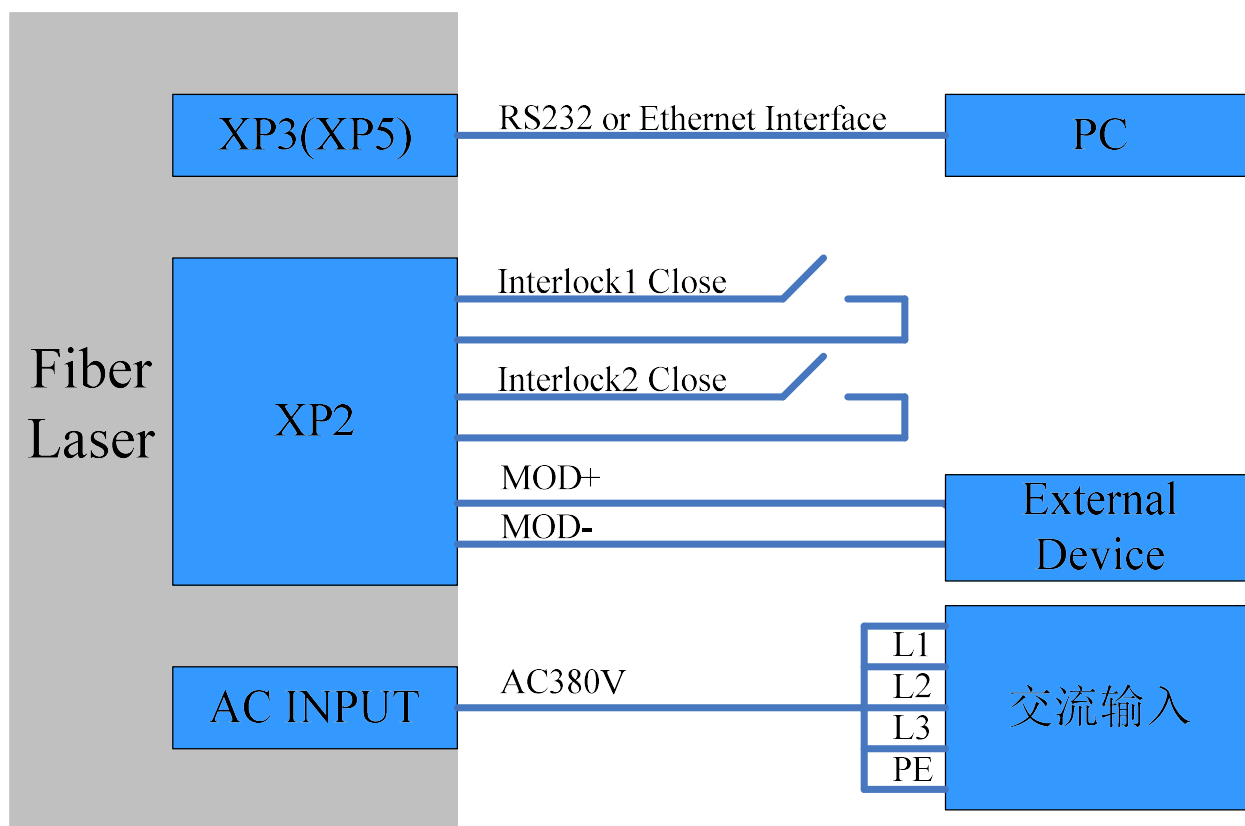

Figure 22 wiring diagram of Emission external control mode set by power communication in ON mode

Operation methods:

- a) The rear panel air switch hits ON to supply power to the laser.
- b) The front panel key switch is turned ON to put the laser into ON mode.
- c) Open the upper computer software.
- d) Click the red ON button to view the red light.
- e) turn off the AD mode, open the external control mode.(this mode can be remembered when the power is off.)
- f) click the main power ON button in the upper computer software to turn on the main power.
- g) wait for the laser tricolor light green light to light up, the laser preparation work is completed.
- h) Set the light output parameters.
- i) External MOD signal output high level to turn on the laser.
- j) Check the laser tricolor light is on red, the laser is outputting light.

### 6.3 Emission external control set by power analog in ON mode

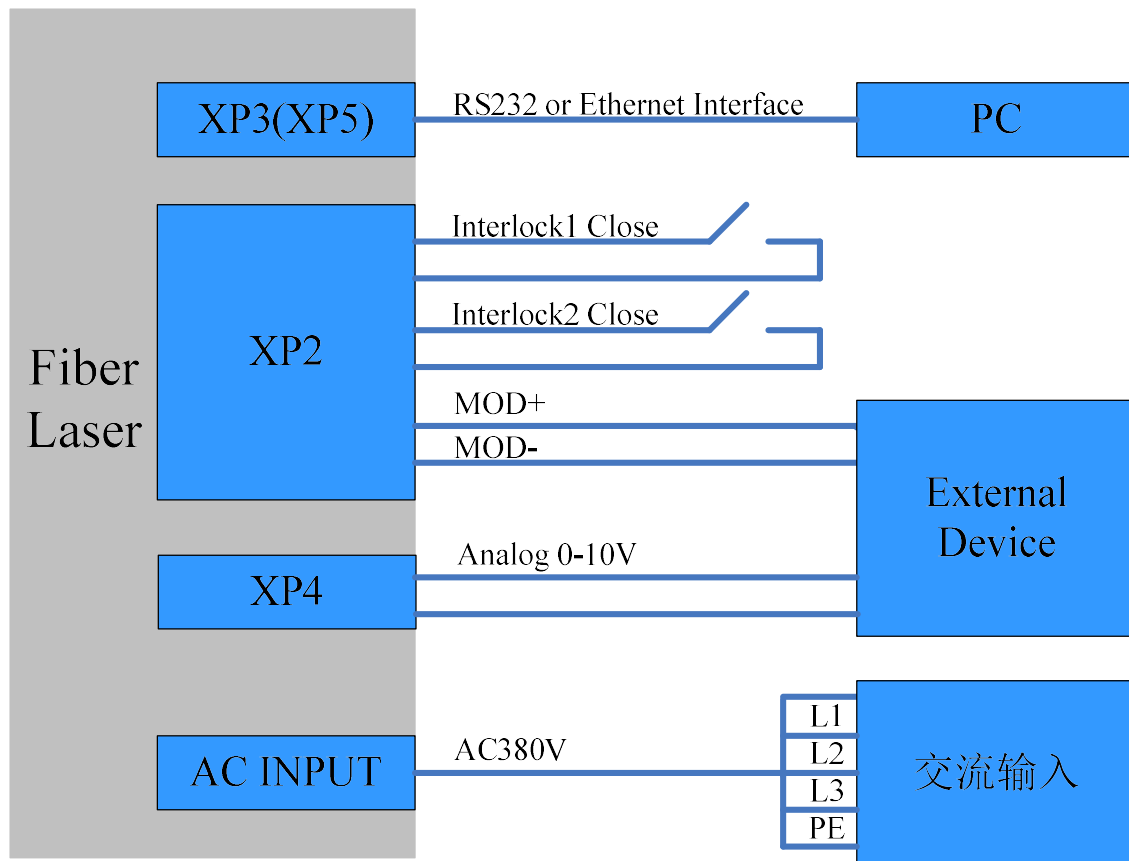

Figure 23 Wiring diagram of emission external control set by power analog on the ON mode

Operation methods:

- The rear panel air switch hits ON to supply power to the laser.
- The front panel key switch is turned ON to put the laser into ON mode.
- Open the upper computer software.
- Hit the red ON button to view the red light.
- open AD mode, open external control mode.(this mode can be remembered when power is lost.)
- click the main power ON button in the upper computer software to turn on the main power.
- wait for the laser tricolor light green light on, the laser ready to work completed.
- Output analog and outgoing light signals through the control board.
- Check that the red light of the laser tricolor lamp is on, and the laser is outputting light.

#### 6.4 Emission external control through programming mode on the ON mode

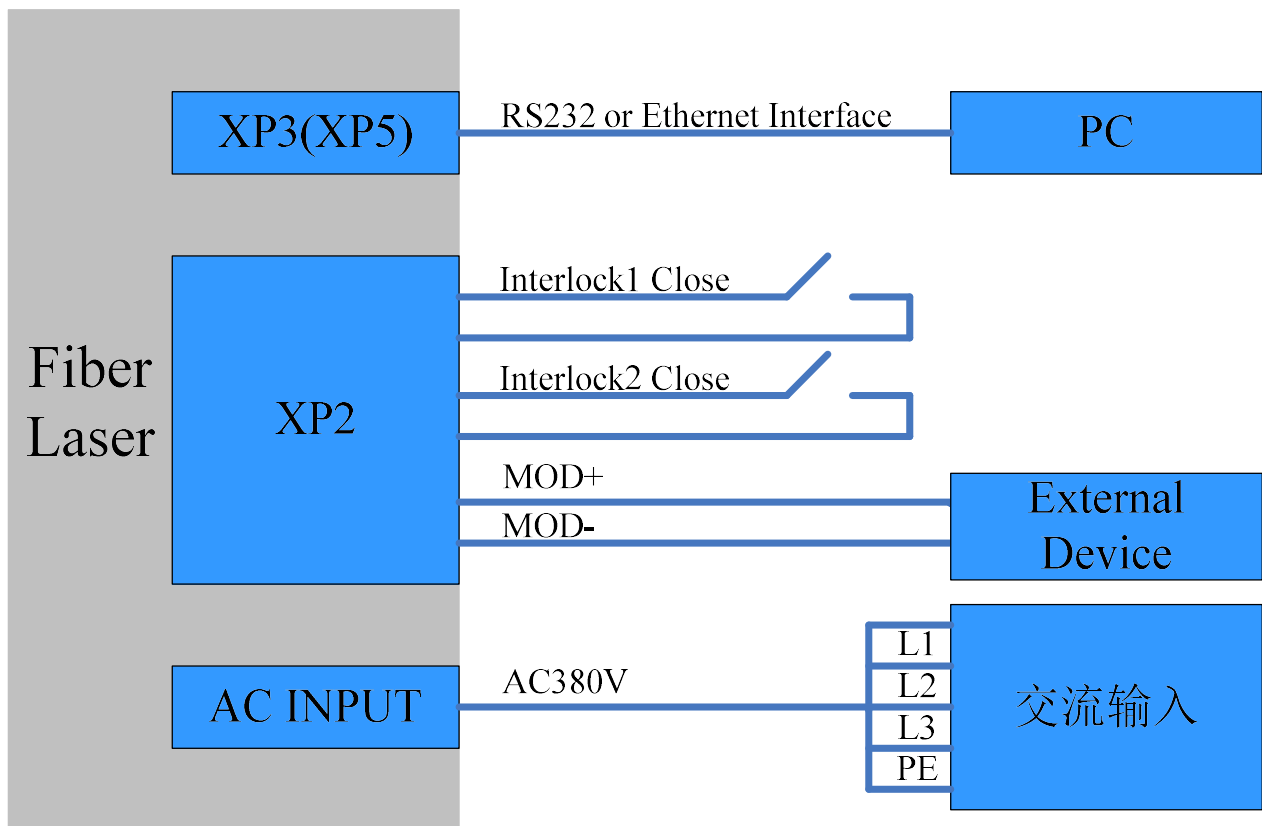

Figure 24 Wiring diagram of Emission external control through programming mode on the ON mode

Operation methods:

- a) The rear panel air switch hits ON to supply power to the laser.
- b) The front panel key switch is turned ON to put the laser into ON mode.
- c) Open the upper computer software.
- d) Click the red ON button to view the red light.
- e) Click the main power ON button in the upper computer software to turn on the main power.
- f) Wait for the laser tricolor light to turn on green and the laser preparation is completed.
- g) Set the waveform number for pre-execution (program number is greater than 0).
- h) Start the waveform on the rising edge of the external MOD signal.
- i) Check that the red light of the laser tricolor lamp is on, and the laser is outputting light.

Note: high level time of MOD must be more than program operation; if MOD gives the falling edge in advance, the computer software will show that the laser program is stopped abnormally.

## 6.5 Set the power analog as emission external control on the REM mode

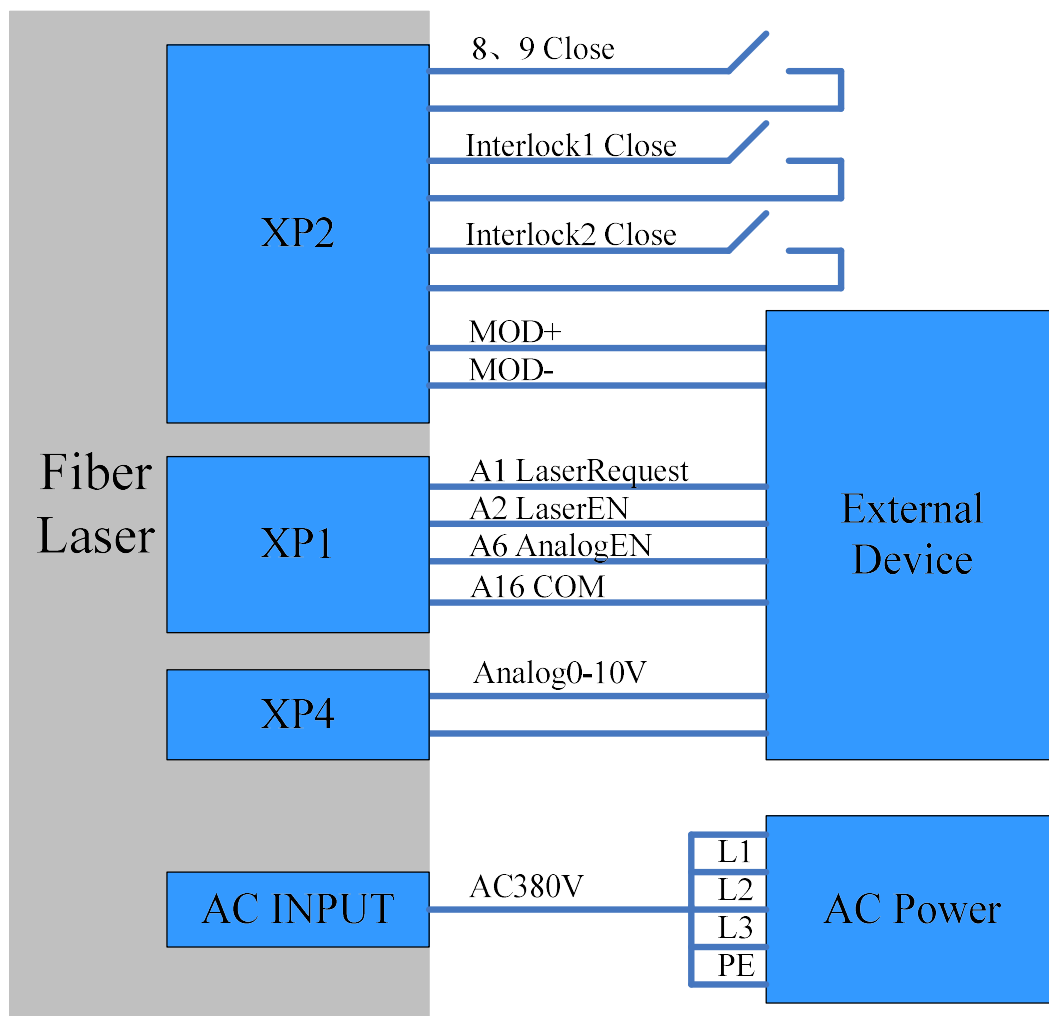

Figure 25 Wiring diagram of setting the power analog as emission external control on the REM mode

Operation methods:

- The rear panel air switch hits ON to supply power to the laser.
- Front panel key switch to REM, the laser into REM mode.
- Shorting pin 8 and pin 9 on XP2 to supply power to the main control board.
- XP1-A1 is connected to 24V and XP1-A6 is connected to 24V to enter the external control analog mode.
- XP1-A5 is connected to 24V to turn on the red light. XP1-A5 is connected to 0V to turn off the red light.
- XP1-C1 is connected to 24V, and the main power is turned on (you can also press the LASER button directly, or the upper computer software points the main power ON).

- g) Wait for the green light of the laser tricolor lamp to light up, and the laser preparation work is completed.
- h) XP1-A2 is connected to 24V, and the control board outputs analog and MOD signals.
- i) Check that the red light of the laser tricolor lamp is on, and the laser is outputting light.

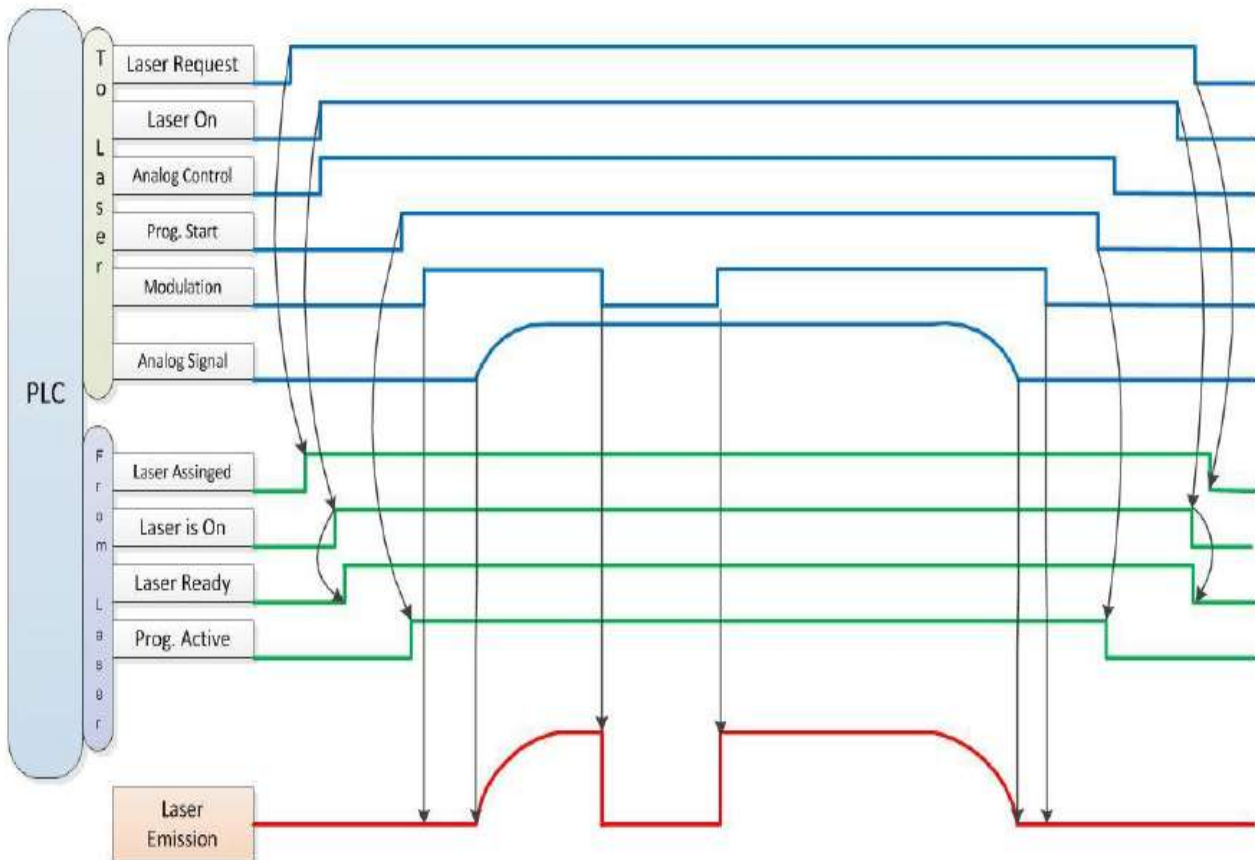

Figure 26 timing diagram of setting power analog as emission external control signal on REM mode

## 6.6 REM mode power communication set out light external control

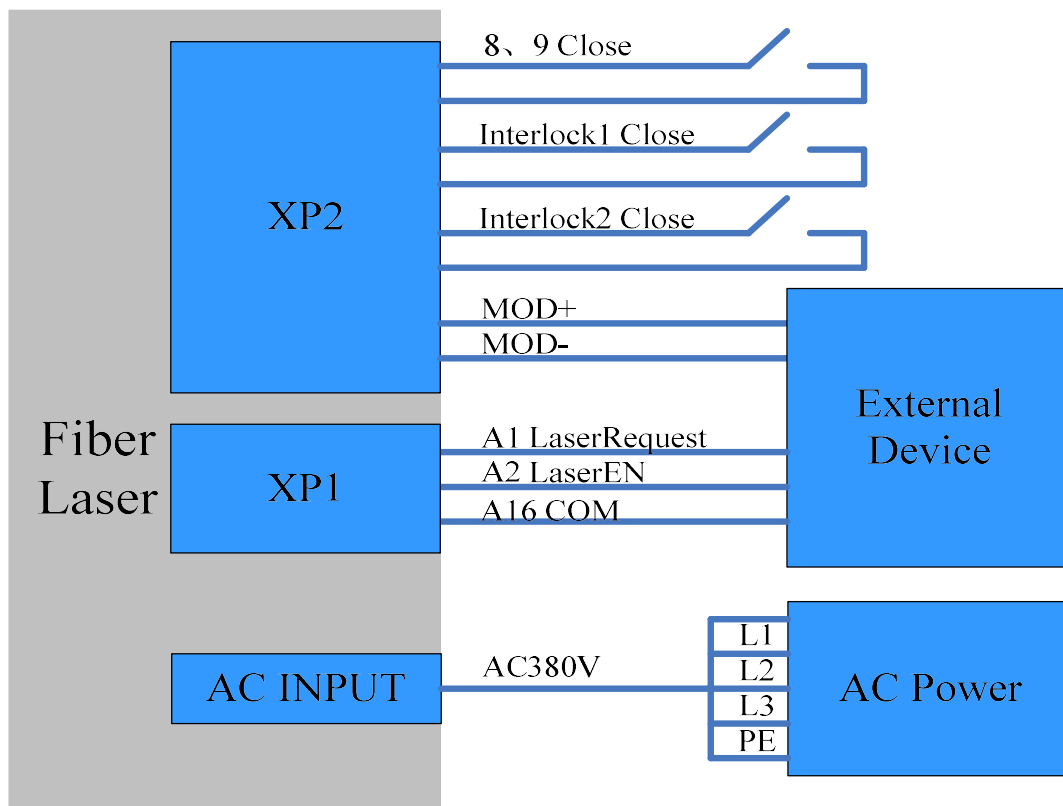

Figure 27 Wiring diagram of setting power communication as emission external control on REM mode operation methods:

- a) The rear panel air switch hits ON to supply power to the laser.
- b) Front panel key switch to REM, the laser into REM mode.
- c) Shorting pin 8 and pin 9 on XP2 to supply power to the main control board.
- d) XP1-A1 is connected to 24V.
- e) XP1-A5 is connected to 24V to turn on the red light; XP1-A5 is connected to 0V to turn off the red light after checking the optics.
- f) XP1-C1 is connected to 24V, and the main power is turned on (you can also press the LASER button directly, or the upper computer software points the main power ON.).
- g) wait for the green light of the laser tricolor lamp to light up, the laser preparation work is completed.
- h) The software of the upper computer sets the light output power, XP1-A2 connects to 24V and controls the board MOD signal.
- i) Check the laser tricolor lamp red light is on and the laser is outputting light.

## 6.7 Programming mode in REM mode

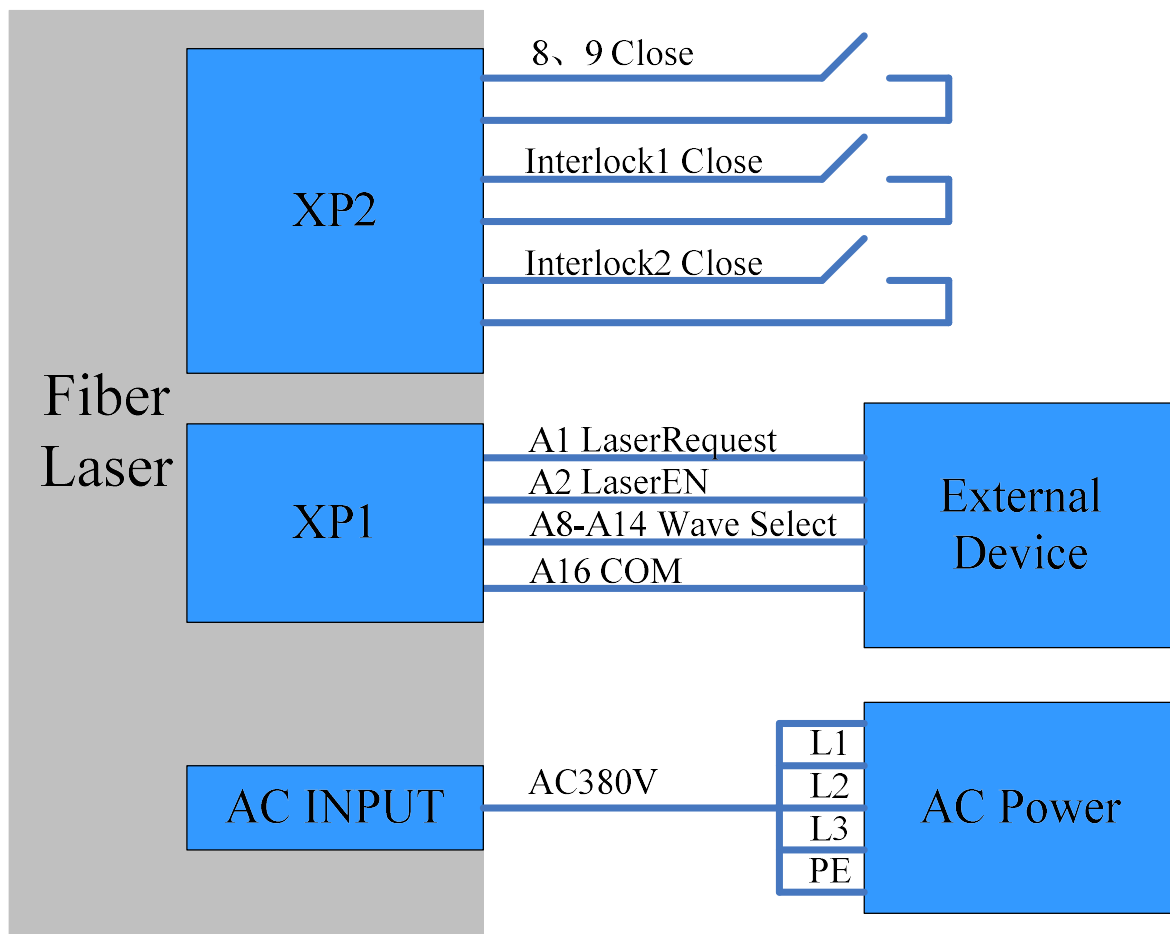

Figure 28 Wiring diagram of programming mode on REM mode

Operation methods:

- a) The rear panel air switch hits ON to supply power to the laser.
- b) Front panel key switch to REM, the laser into REM mode.
- c) Shorting pin 8 and pin 9 on XP2 to supply power to the main control board.
- d) XP1-A1 is connected to 24V.
- e) XP1-A5 is connected to 24V to turn on the red light; XP1-A5 is connected to 0V to turn off the red light after checking the optics.
- f) XP1-C1 is connected to 24V, and the main power is turned on (you can also press the LASER button directly, or the upper computer software points the main power ON).
- g) Wait for the laser tricolor light to turn on green, the laser preparation is completed.
- h) XP1-(A8-14) select the pre-executed program number, XP1-A2 set to high to start the execution of the program.

i) Check that the laser tricolor red light is on, and the laser is outputting light.

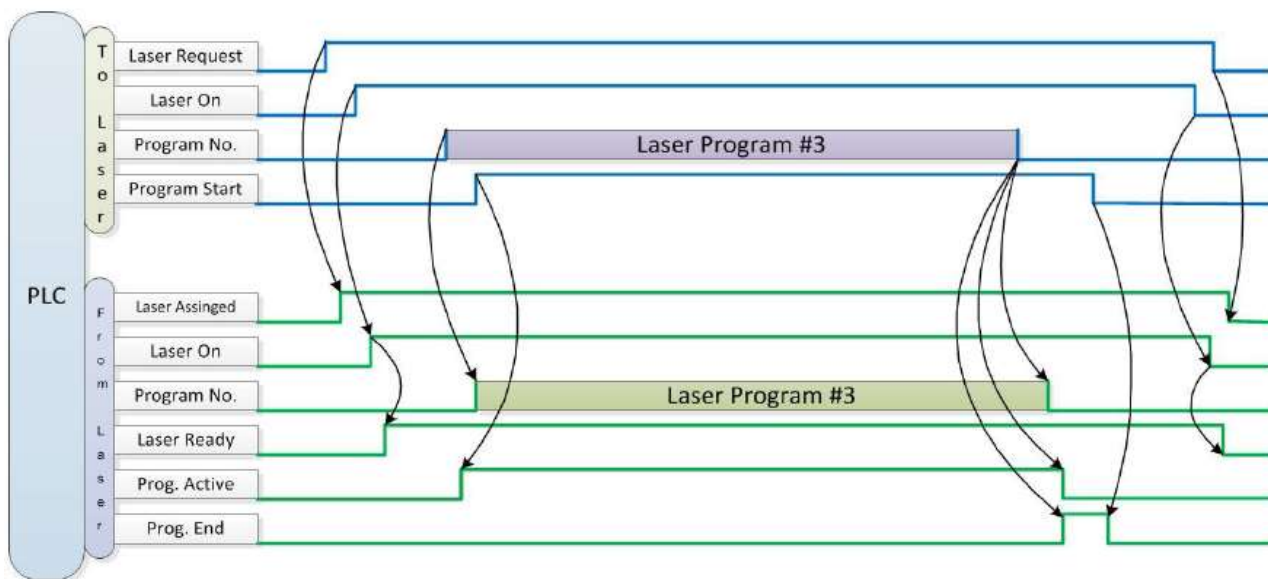

Figure 29 Timing diagram of control signal of programming mode

## 7 RS232 and INTERNET Communication Command

### 7.1 Port Configuration

RS-232 configuration is as follows:

Baud rate :9600, data bit :8, stop bit :1, no parity bit and no control flow

Ethernet port is configured as follows

Default laser IP address :192.168.0.10

Laser port :10001

### 7.2 Laser Communication Protocol (Network Port & Serial Port)

All commands and return values in this Agreement are composed of ASCII characters. Note the following points when entering.

- a) Commands generally consist of three or four letters, sometimes with additional values.
- b) All commands and return values end with the enter character (CR,0x0D, \r). If the product receives a string character with “enter” but the command is invalid, it will return “Command Err!\r”.
- c) For easy identification, all commands are capital letters, but in fact this product is not case-sensitive. For easy identification, a space is added between the command and the parameter.
- d) This product sends a return value for every command received. The return value generally contains the command content itself. If the returned content contains a numeric value or contains

an error type, “:” will be used to separate the returned command content and the numeric value or the error type.

The specific agreement content and command examples of this product are shown in Table 11.

Table 11 Specific Protocol Contents and Command Examples of Laser

Command	Description	Command Example
ABF	Aiming Beam OFF – Turn off red light	Send: ‘ABF\r’ Return: ‘ABF\r’
ABN	Aiming Beam ON – Turn on red light	Send: ‘ABN\r’ Return: ‘ABN\r’
DEABC	Disable External Aiming Beam Control	Send: ‘DEABC\r’ Return: ‘DEABC\r’
EEABC	Enable External Aiming Beam Control	Send: ‘EEABC\r’ Return: ‘EEABC\r’
DEC	Disable External Control	Send: ‘DEC\r’ Return: ‘DEC\r’
EEC	Enable External Control	Send: ‘EEC\r’ Return: ‘EEC\r’
DLE	Disable Hardware Emission Control	Send: ‘DLE\r’ Return: ‘DLE\r’
ELE	Enable Hardware Emission Control	Send: ‘ELE\r’ Return: ‘ELE\r’
EMOFF	Stop Emission	Send: ‘EMOFF\r’ Return: ‘EMOFF\r’
EMON	Start Emission	Send: ‘EMON\r’ Return: ‘EMON\r’
MPWROFF	Main Power OFF	Send: ‘MPWROFF\r’ Return: ‘MPWROFF\r’
MPWRON	Main Power ON	Send: ‘MPWRON\r’ Return: ‘MPWRON\r’
SPW	Set Pulse Width	Send: ‘SPW 100\r’ Return: ‘SPW:100\r’ ( Set pulse width as 100ms ) Other return values: ‘ERR: input Err\r’ ( Input pulse width <0.0001 ) ‘ERR: Out of Range\r’ ( Over maximum pulse width ) ‘ERR: Duty Cycle too High\r’ ‘ERR: Duty Cycle too Low\r’ ‘SPW:100,Duty=100%\r’

SPRR	Set Pulse Repetition Rate	Send: 'SPRR 1000\r' Return: 'SPRR: 1000\r' 'ERR: input Err\r' 'ERR: Out of Range\r' 'ERR: Duty Cycle too High\r' 'ERR: Duty Cycle too Low\r' 'SPW: 100, Duty=100%\r'
SDC	Set Diode Current (%) The set value must be less than 100% and above the minimum current setting value, which can be set to 0. If the set value is greater than 100, the default is input 100.	Send: 'SDC 100\r' Return: 'SDC: 100\r' Other return values: 'ERR: Input Err\r' 'Laser is worked in AD Mode\r'
RCS	Read Current Setpoint	Send: 'RCS\r' Return: 'RCS: 56.7\r' (The current set value is 56.7 %)
RPRR	Read Pulse Repetition Rate (Hz)	Send: 'RPRR\r' Return: 'RPRR:10\r' (Repeat frequency is 10Hz)
RBT	Read Board Temperature	Send: 'RBT\r' Return: 'RBT:36.6\r'
RPW	Read Pulse Width (MS)	Send: 'RPW\r' Return: 'RPW:5.5\r' (pulse width is 5.5ms)
RCT	Read Laser Temperature	Send: 'RCT\r' Return: 'RCT:34.5\r'
PERR	Reset Errors	Send: 'PERR\r' Return: 'PERR\r'
SUT	Set Up Time (MS)	Send: 'SUT 50\r' Return: 'SUT:50\r'
SDT	Set Down Time (MS)	Send: 'SDT 50\r' Return: 'SDT:50\r'
RUT	Read Up Time (MS)	Send: 'RUT\r' Return: 'RUT:50\r'
RDT	Read Down Time (MS)	Send: 'RDT\r' Return: 'RDT:50\r'
PSRT	Program Start	Send: 'PSRT 1\r' Return: 'PSRT:1\r'
PSTP	Program Stop	Send: 'PSTP\r' Return: 'PSTP\r'
ECM	Enable Calibration Mode –Power linear correction mode (in this mode, the external analog is corrected and output after filtering, so the response time of AD analog is larger than that of through mode)	Send: 'ECM\r' Return: 'ECM\r'

DCM	Disable Calibration Mode (AD analog response time is less than 100 us in this mode)	Send: 'DCM\r' Return: 'DCM\r'	
Others	Command error	Send: 'BGM\r' Return: 'Command Err! \r'	
STA	Read device status – Read the product status. A return value of 32-Bit digital information. The meaning of each Bit is as follows (undefined or 'reserved' Bit negligible):	Send: 'STA' Return: 'STA:4100' returned value 4100(Decimal) can be converted to 0 x1004 (hexadecimal), and then converted to binary to see that Bits2 and 12 have been set.The laser enable is on and the modulation mode is enabled	
	Bit 0		Normal operation Authorization time
	Bit 1		Normal Temperature too high
			Bit 2
	Bit 3		
			Bit 4
	Bit 5		
			Bit 6
	Bit 7		
			Bit 8
	Bit 9		
			Bit 10
	Bit 11		
			Bit 12
	Bit 13		
			Bit 14

STA	Bit 15	No laser	Send: 'STA' Return: 'STA:4100' returned value 4100(Decimal) can be converted to 0 x1004 (hexadecimal), and then converted to binary to see that Bits2 and 12 have been set.The laser enable is on and the modulation mode is enabled
		Laser is power on	
	Bit 16	Gate mode=off	
		Gate mode=on	
	Bit 17	AC input normal	
		AC input abnormal	
	Bit 18	External Emission control=off	
		External Emission control=on	
	Bit 19	Normal	
		Laser fault	
	Bit 20	Slow up slow down mode off	
		Slow up slow down mode on	
	Bit 21	A laser operates in ON" mode	
		A laser operates in REM" mode	
	Bit 22	Wave mode off	
		Wave mode on	
	Bit 23	Surge protector Normal	
		Surge protector failure	
	Bit 24	Normal	
		Low temperature fault	
Bit 25	Normal		
	Humidity alarm		
Bit 26	Normal		
	Water flowmeter 1 Flow Alarm		
Bit 27	Red light internal control		
	Red Light External Control		
Bit 28	Normal		
	Water flowmeter 2 Flow Alarm		
Bit 29	Normal		
	Module locked		
Bit 30	Optical circuit safety interlock normal		
	Optical circuit safety interlock abnormal		
Bit 31	Normal		
	High average power		

## 8 PC Software Instructions

PC software download address: <http://www.raycuslaser.com/list/56.html>

### 8.1 Main interface of PC software

The main interface of PC computer software display is shown in Figure 30.

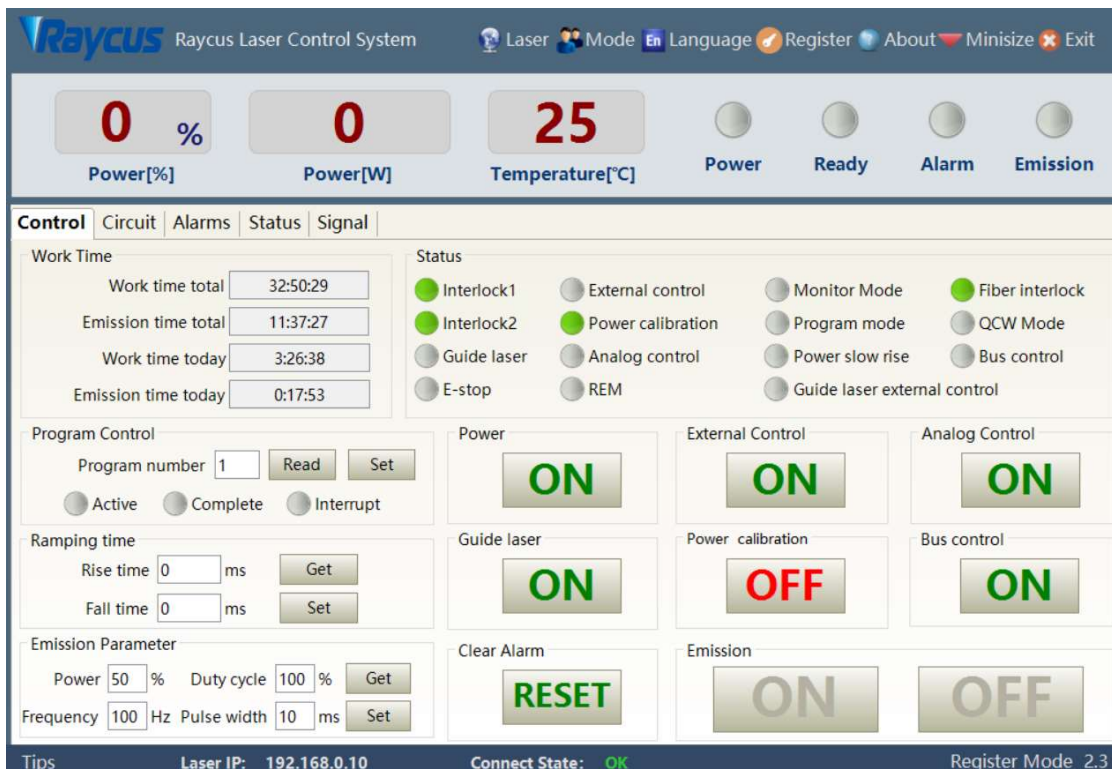

Figure 30 The main interface of PC computer software display

### 8.2 Multi-laser Control Area

Multi-laser control area is shown in Figure 31.

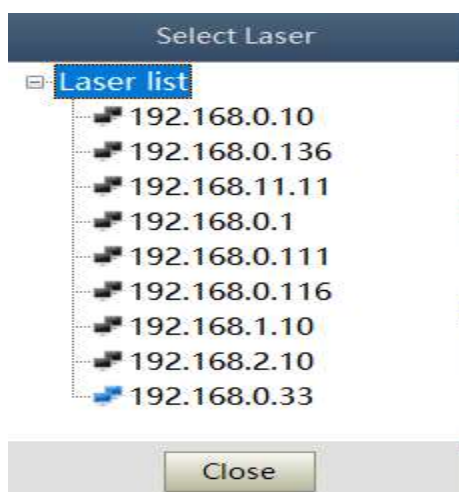

Figure 31 Multi-laser control area interface

Select IP address of corresponding laser, and then double-click. PC software will take communication with selected laser. After the communication established, the bottom status shows that the network connection is ok, shown in Figure 32.



Figure 32 communication status interface between PC software and laser

### 8.2.1 Add/delete laser

In the PC software, right-click in the laser list area to add/delete lasers. When adding a laser, you need to enter the IP address of the added laser. The specific operation is shown in Figure 33.

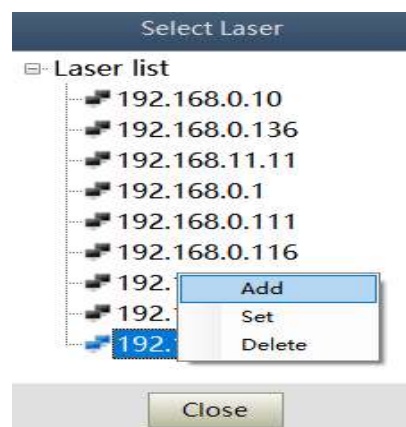

a)

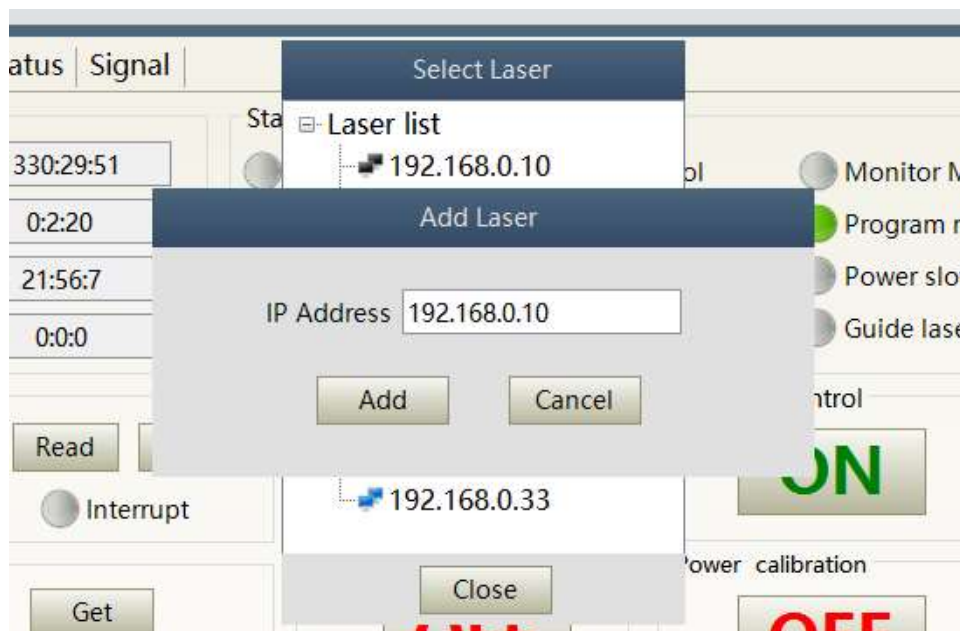

b)

Figure 33 Procedure for adding a laser to the PC software

## 8.2.2 Modify laser IP

After the laser has established a connection, select the IP address of current laser and right-click to set it up in Figure 34.

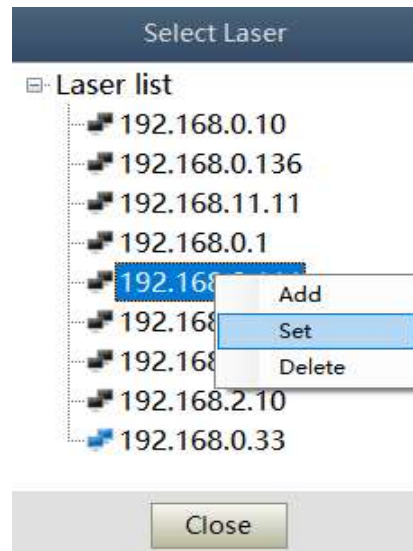

a)

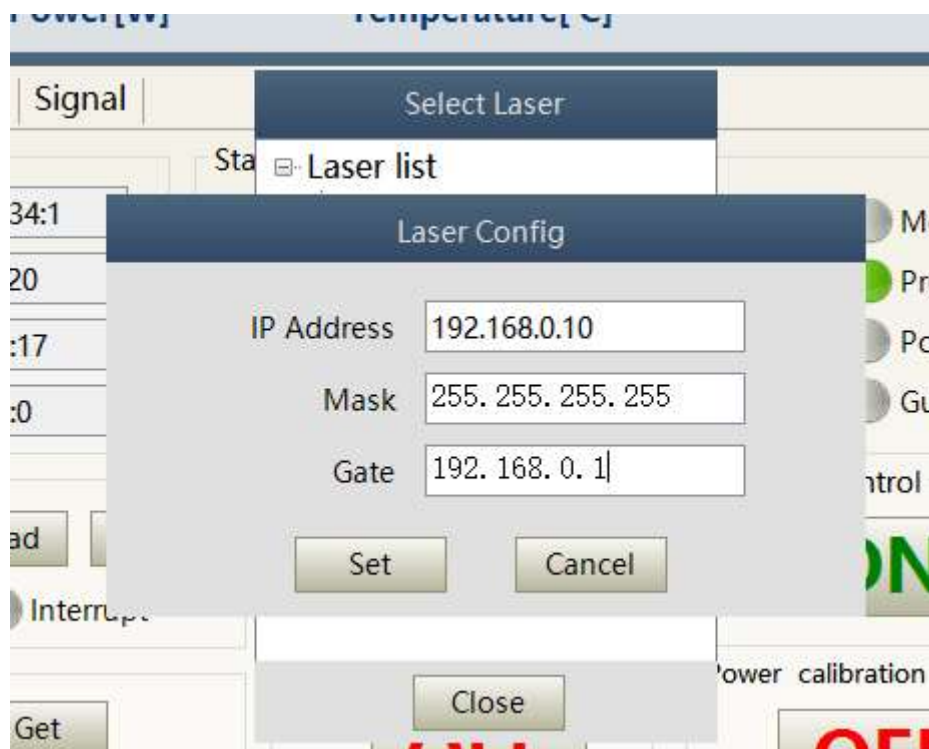

b)

Figure 34 Modify the IP address of laser

### 8.3 Main working status display

The laser’s main status display is as shown in Figure 35, Table 12.



Figure35 diagram of the laser's main display area

Table 12 the laser main display content and meaning

Display	Meaning
Output power	current set percentage of power in real time
Output power	Average laser output power in real time ( W )
Laser temperature	Water cooling temperature in real time ( °C )
Power light	Status of main power supply: green-main power supply is on gray-main power supply is off
Ready light	Indicates readiness of current laser: green-laser is ready gray-laser is not ready
Alarm light	indicates alarm status of current laser: yellow- laser is abnormal gray-laser is normal
Emission light	indicates the working model of the current laser: red laser is in working model gray-laser is not in output model

#### 8.3.1 Laser’s cumulative operating time display area

The laser’s cumulative operating time display is shown in Figure 36. The cumulative start-up time, cumulative laser output time, today's power-on time and today's lighting time can be displayed in hours, minutes and seconds, respectively.



Figure 36 laser’s cumulative operating time display interface

### 8.3.2 Laser working status display area

The laser working status display area is shown in Figure 37, Table 13.



Figure 37 A diagram of the laser's working status display area

Table13 The laser main display area clarification

Display	Content explanation
Emergency stop	Red: emergency stop button on front panel is pressed Gray: emergency stop button is reset
REM	Green: laser works in REM mode Gray: laser works in ON mode
Red laser external control	Green: laser works in red laser external control mode Gray: laser works in red laser internal mode. Laser on/off controllable by software
Red laser	Green: red laser is ON Gray: red laser is OFF
Output fiber Interlock status	Green: Interlock spot at output fiber end is made Gray: Interlock spot at output fiber end is disconnected
External control model	Green: Laser works in external control mode Gray: laser works in internal control mode. Laser ON/OFF is controllable by software
Power correction	Green: Laser operates in power linear correction mode, in which control system automatically adjusts the laser's output power. It makes the output power linear, with a longer response time for AD analog in this mode, longer than 1mS. Gray: laser operates in non-correction mode, and the external 0-10V analog voltage is linear only with the current of the pump auxiliary tube. The response time for this mode AD simulation is less than 100uS.
AD model	Green: Laser power is determined by the 0-10V analog voltage on XP4 when laser works in AD mode. Gray: laser power is set by PC software or communication commands.
Monitoring model	Green: PC software is in monitoring mode. User can monitor laser status only, but not able to take control of laser. Monitoring model is activated when interface 10001 of laser occupied. Gray: PC software operate in Normal mode
InterLock1 make	Green: XP2 leg 17,20 on safety interface make Gray: XP2 leg 17,20 on safety interface break

InterLock2 make	Green: XP2 leg 18,19 on safety interface make Gray: XP2 leg 18,19 on safety interface break
Programming mode	Green: laser in programming mode Gray: laser not in programming mode
Power slow rise & down mode	Green: laser in power slow rise & down mode Gray: laser not in power slow rise & down mode

### 8.3.3 Laser power-up, mode selection, light-out control area

Laser power-up, mode selection, light out control display area is as in Figure 38, the display content is as in Table 14.



Figure 38 Laser power-on, mode selection, light out control display area

Table 14 Laser power-on, mode selection, light out control display area explanation

Display content	Explanation
Main power button	Click ON, main power on click OFF, main power off
External control mode	Click ON, activate laser external control Click OFF, shut laser external control; mode power-off memory automatically
AD mode	Click ON, AD analog mode on Click OFF, AD analog mode off. mode power-off memory automatically
Red guide beam	Click ON, red guide beam on Click OFF, red guide beam off
Power correction	Click ON, activate laser power correction mode Click OFF, shut laser power correction mode; mode power-off memory automatically
Eliminate alarm	Eliminate current laser alarm
Laser ON	Laser is in output
Laser OFF	Laser is off

### 8.3.4 Programming mode test area

The laser programming mode test area interface is shown in Figure 39, in which the ‘START’ button is used to test the programming of the programming mode. This function can only run internal mode (when external mode is turned off). Enter the current pre-tested programming number in the digital text box and click the START button.

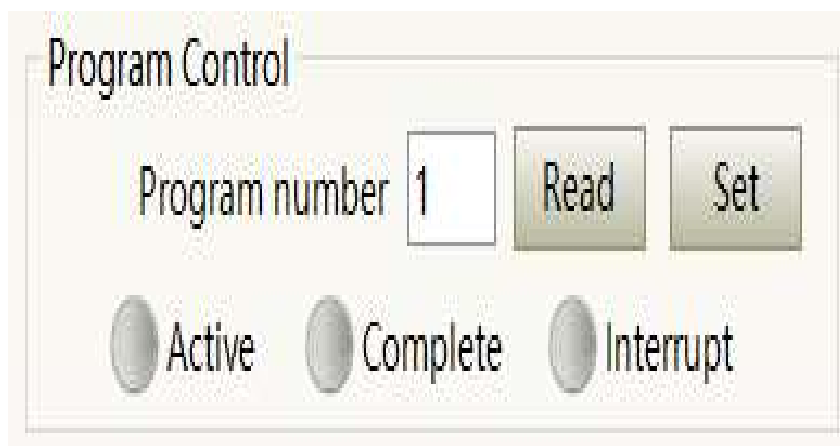
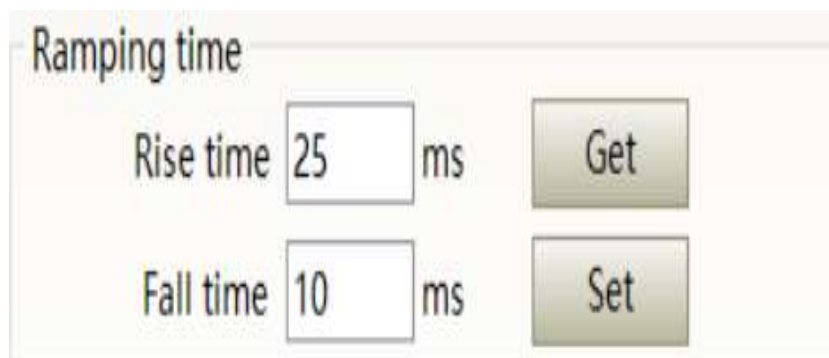

Figure 39 Laser programming mode test area display interface

### 8.3.5 Power slow rise & down parameter setting area

The interface of the laser power slow rise & fall parameter setting area is shown in Figure 40. Click ‘Get’ to read the power rise and fall times stored in the laser. Click ‘Set’ to set a new power rise and fall time. When the rise and fall, times are set to 0, the power slow rise & fall function is automatically switched off. When there is no 0, the slow rise or fall function is automatically turned on.



a)

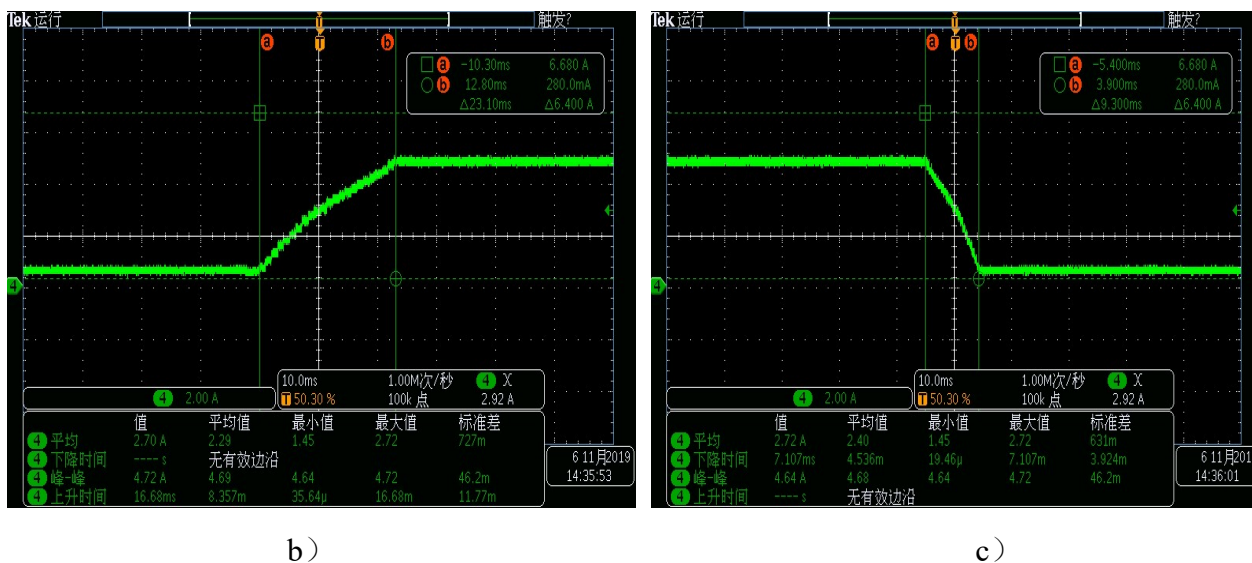

Figure 40 the power slow rise and fall setting area interface and measured programming

### 8.3.6 Laser output parameters read the setting area

Laser output parameter setting interface is shown in Figure 41. The output parameter setting is not valid when AD mode is on.

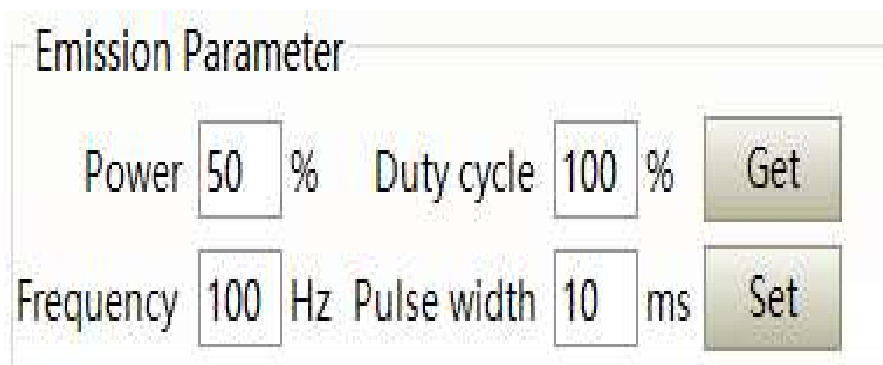

Figure 41 Laser output parameter setting area display interface

### 8.4 Laser status display area

The display interface for laser status display area is shown in Figure 42. The module status is used to shield the faulty module, the green light indicates the number of modules installed inside the current laser, and the check box indicates the module that is running in the current laser.

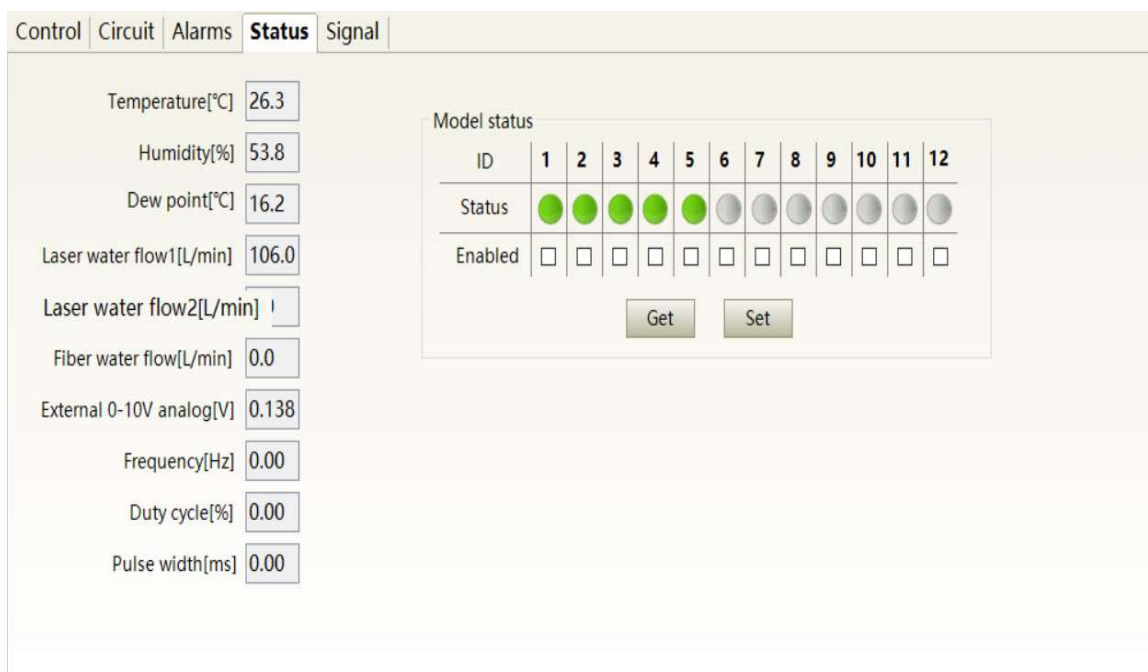

Figure 42 Laser parameter display area display interface

### 8.5 Alarm type display area

The laser alarm type display area interface is shown in Figure 43. This interface shows the cause of the alarm for the current laser.



Figure 43 Laser alarm type display area interface

### 8.6 PC software operating mode selection

The laser operating mode is set by the PC software. Its operating interface is show in Figure 44. The interpretation of the various patterns can be found in Table 15. The programming editing interface is displayed on the software only when programming mode is selected.



Figure 44 Laser operating mode selects the display area interface

Table 15 Laser operating mode and explanation

Mode selection	Mode explanation
User mode	A concise software interface
Diagnostic mode	Displays laser status and parameters for diagnosis purposes
Authorization mode	Time-limited locking function can be set on laser
Debug mode	You can modify laser parameters (subject to valid password)

### 8.7 Language

Laser’s language selection interface is shown in figure 45. User can choose between simplified Chinese and English by clicking ‘setting language’. Setting effective after PC software restarted.



Figure 45 Language selection interface

## 8.8 Authorization (time-limited locking)

### 8.8.1 Authorization on user mode

The authorization settings in user mode are shown in Figure 46. Laser can be locked and unlocked by valid authorization code.



Figure 46 the authorization settings operating interface on user mode

### 8.8.2 Authorization on authorization mode

The authorization settings in laser authorization mode are shown in Figure 47. This interface allows the customer to lock and unlock the machine and can also be used as an authorization code generator.

- The lock time setting can set the effective use time of the laser; for example, the lock time: Oct 1, 2021, means the laser is locked until 0:0 on Oct1,2021. 0/0/2000 means the laser is permanently unlocked.
- The terminal password is set for the laser locking party. The terminal code can only be set once, and no modification is allowed after its set. The terminal password is 8-byte here, e.g, 0123456789ABCDEF, no other characters are allowed.
- The software automatically calculates the authorization code when user click to generate an authorization code. Laser's limited time lock is achieved when user click again to set the authorization time.

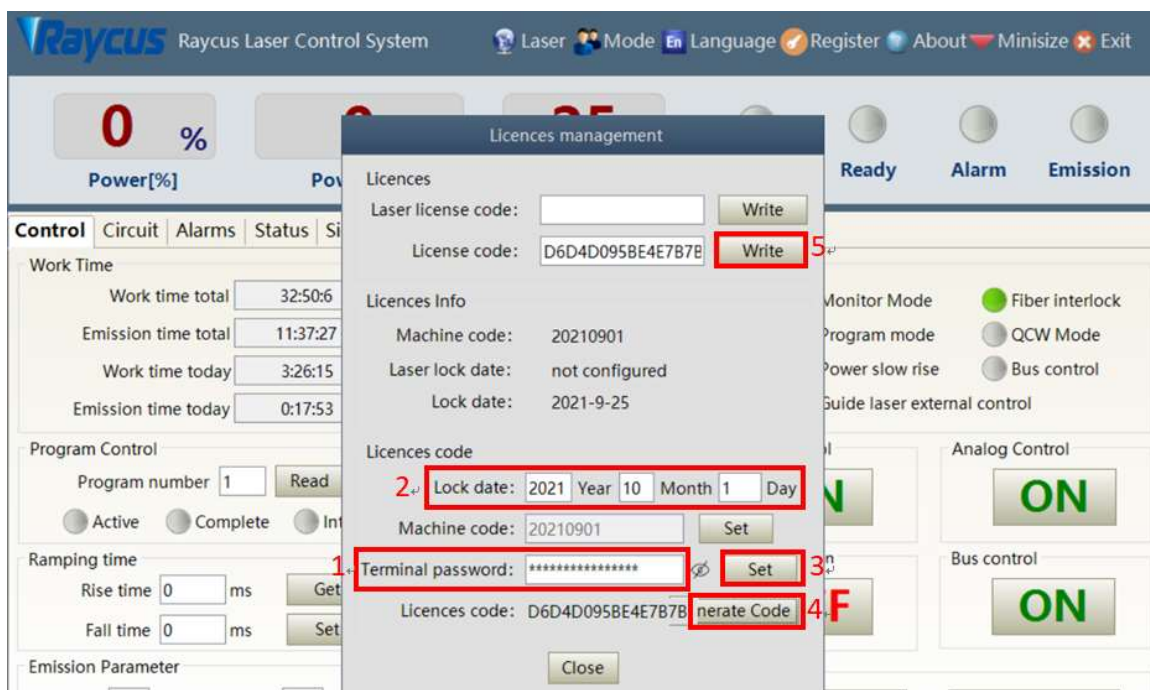

Figure 47 Authorization settings operating interface on authorization mode

## 8.9 About

Laser relevant information such as date of manufacture, model, serial number, controlling serial number, token version number, system information and other information can be queried in the PC software 'about' item. Specific interface is shown in Figure 48.

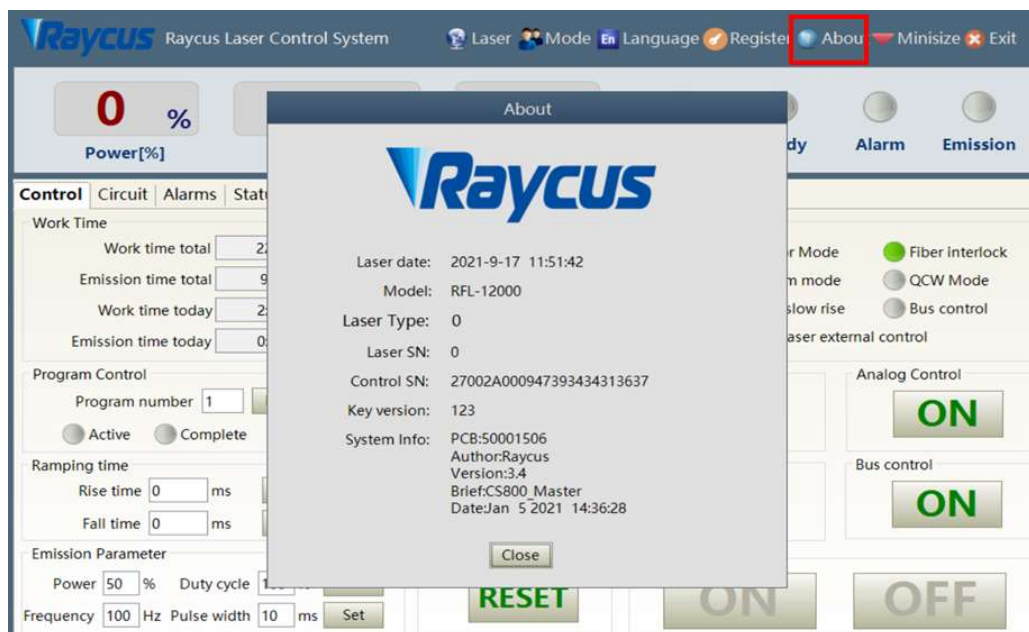

Figure 48 Laser relevant information query interface

### 8.10 XP1 interface status indication (in diagnostic mode)

The laser interface status indicator interface is shown in Figure 49. It is convenient to view the interface status information which represents the input and output status of the XP1 interface on the back panel.

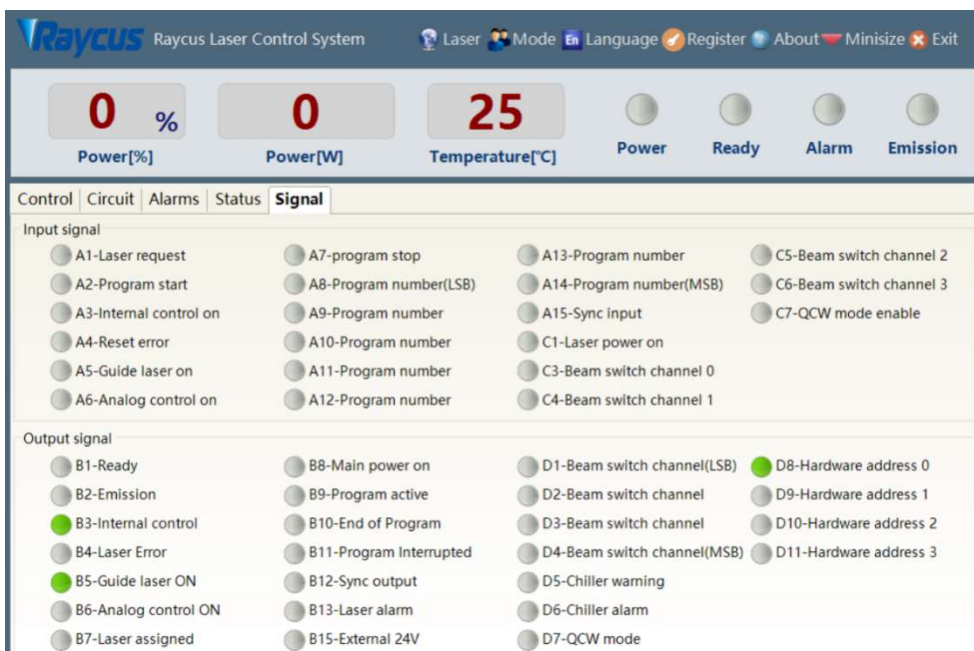

Figure 49 The interface status in diagnostic mode

### 8.11 Log (in diagnostic mode)

Laser’s working log interface is shown in Figure 50. User can query work log by entering the time to query and click on the ‘search’ button.

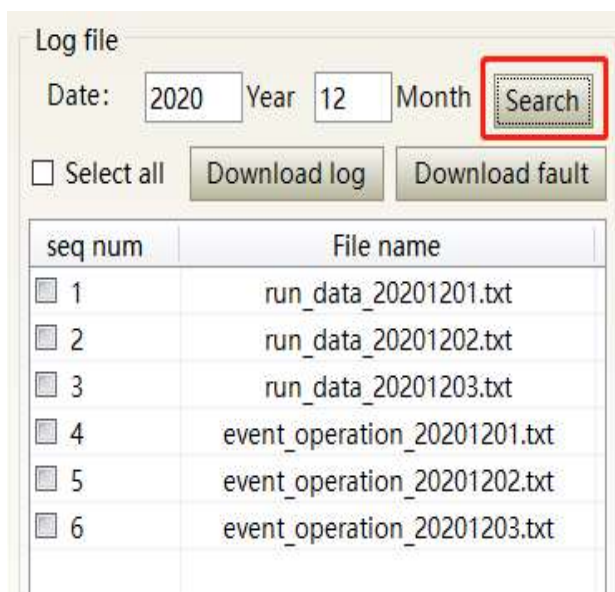

Figure 50 Laser’s working log interface

### 8.11.1 Download log

The interface for downloading the laser operation log is shown in Figure 51.

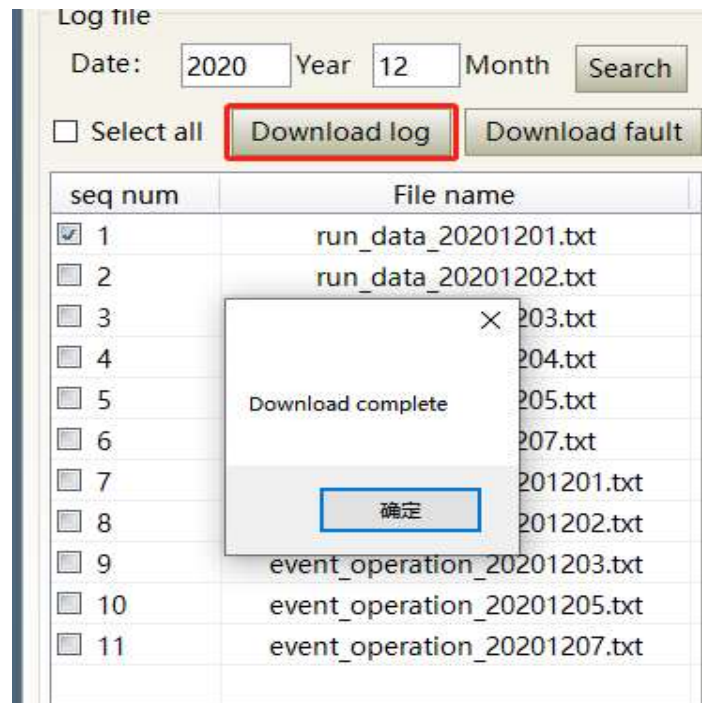

Figure 51 Run Log download interface

### 8.11.2 Download record of historical fault

The interface for downloading historical fault records is shown in Figure 52.

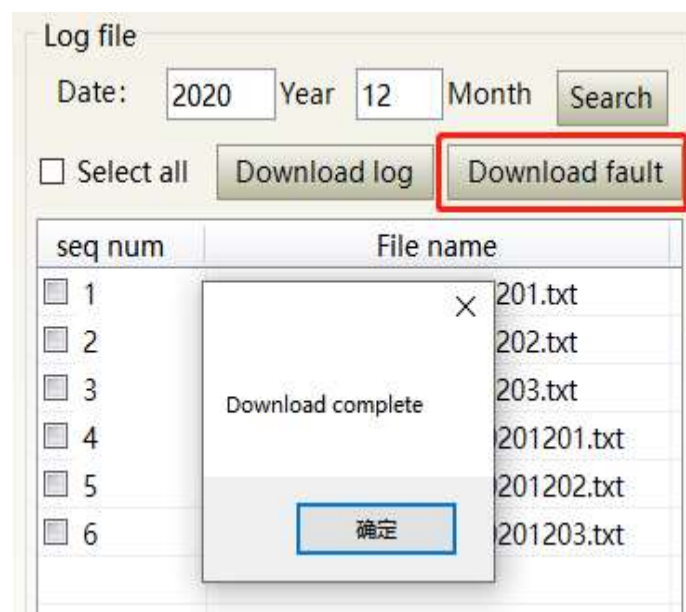

Figure 52 Historical fault record download interface

### 8.11.3 Downloaded file address

The file address query interface for all download information is shown in Figure 53.



Figure 53 the file address query interface for all downloaded information

### 8.12 Module parameters (in diagnostic mode)

Laser module parameter query interface is shown in Figure 54. The interface is for the parameter query in diagnostic mode from which Raycus technicians can analyze the cause of laser anomalies.

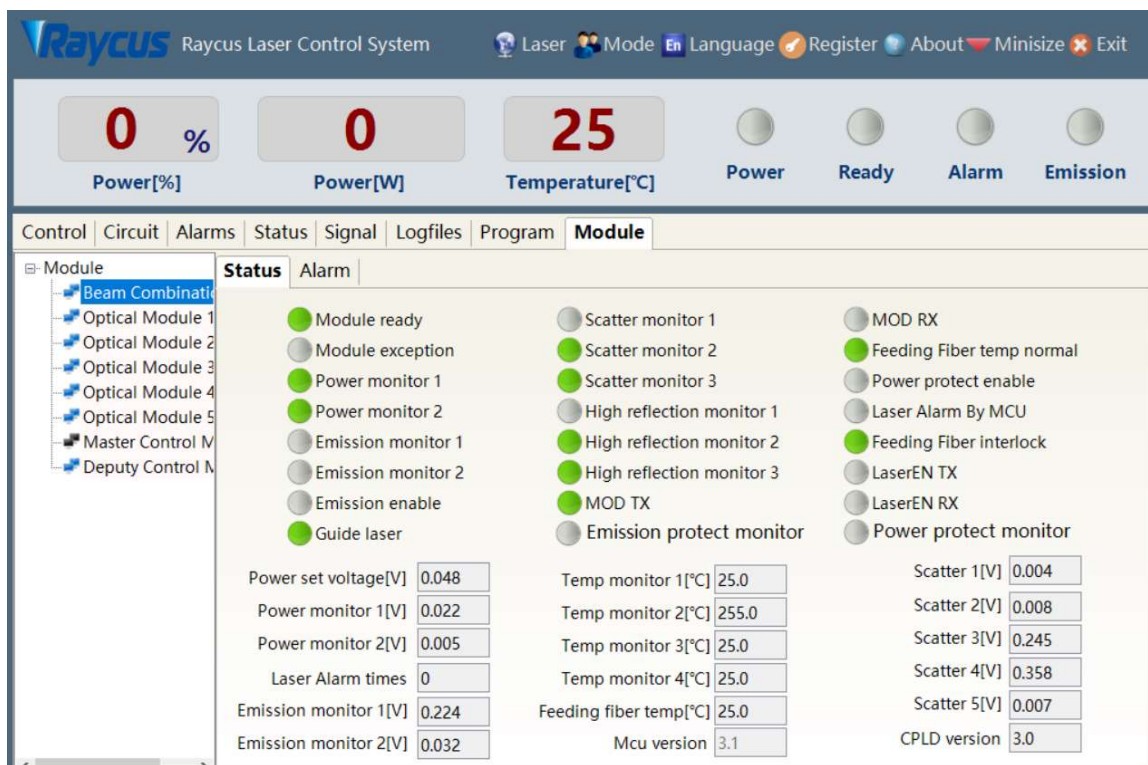

Figure 54 Module parameters query interface in diagnostic mode

### 8.13 Programming settings (programming editing)

The laser programming settings interface is shown in Figure 55.

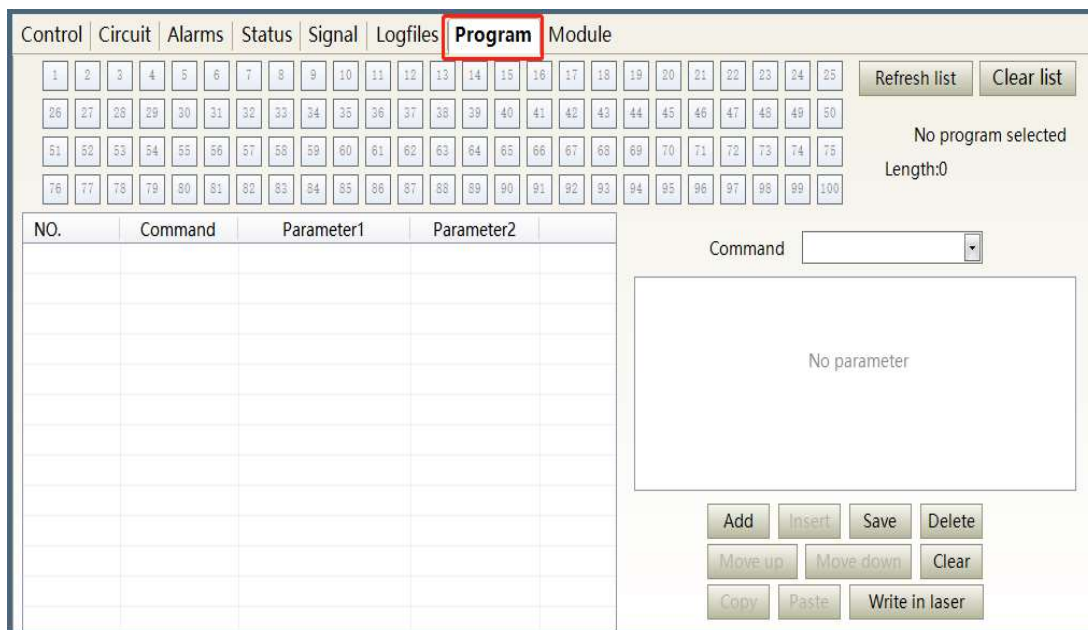

Figure 55 the programming interface in programming editing mode

**8.13.1 View the number of wave bars inside the current laser**

Operating interfaces of viewing the number of wave bar stored inside the current laser is shown in Figure56. The software automatically lists the number of wavelength bars that have been saved by clicking on the ‘Refresher List’ button. Green indicates the bar already has a program and white indicates that the bar is empty.

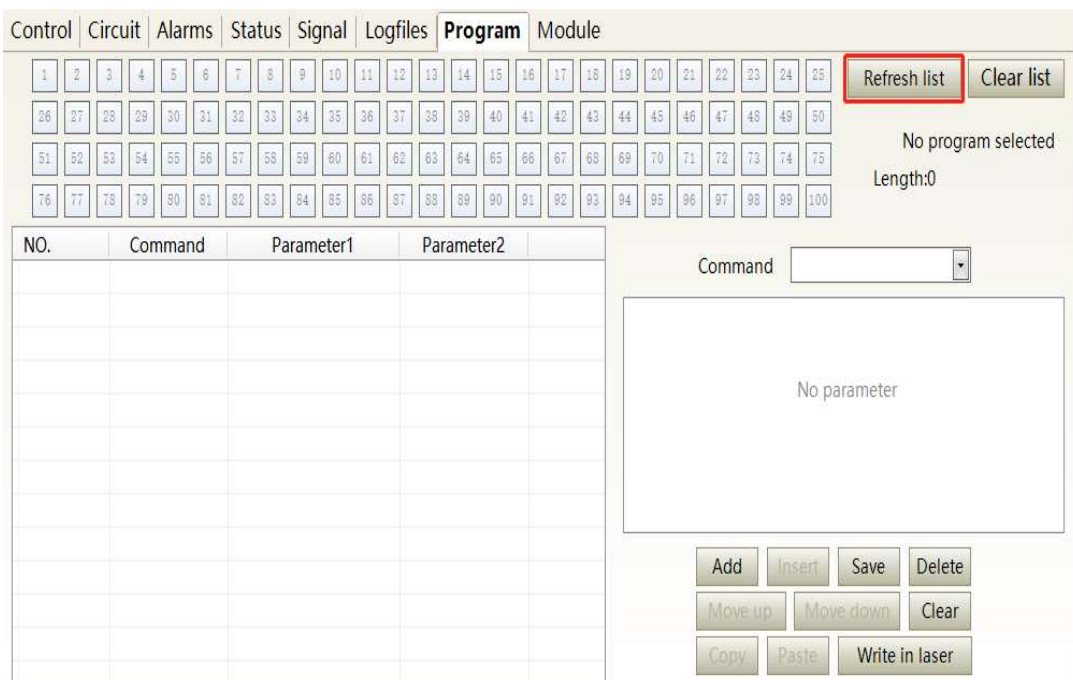

Figure 56 operating interfaces of wave bar stored inside the current laser

### 8.13.2 Check programming content

To check the programming contents in the current laser programming mode is shown in Figure 57. The program automatically lists the original programming by clicking the programming number that needs to be checked.

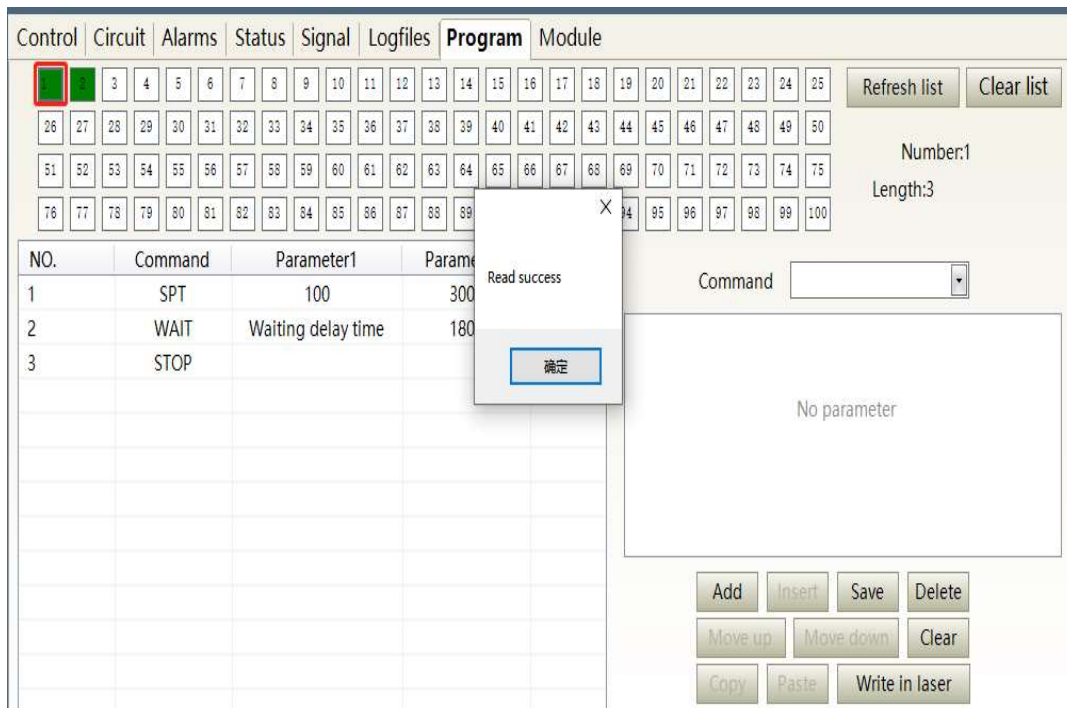

Figure 57 Programming content interface in the current laser programming mode

### 8.13.3 Empty all programming

Empty all programming interfaces stored in the current laser programming mode, as shown in Figure 58. All programming stored inside the current laser will be emptied by clicking 'Clear List'.

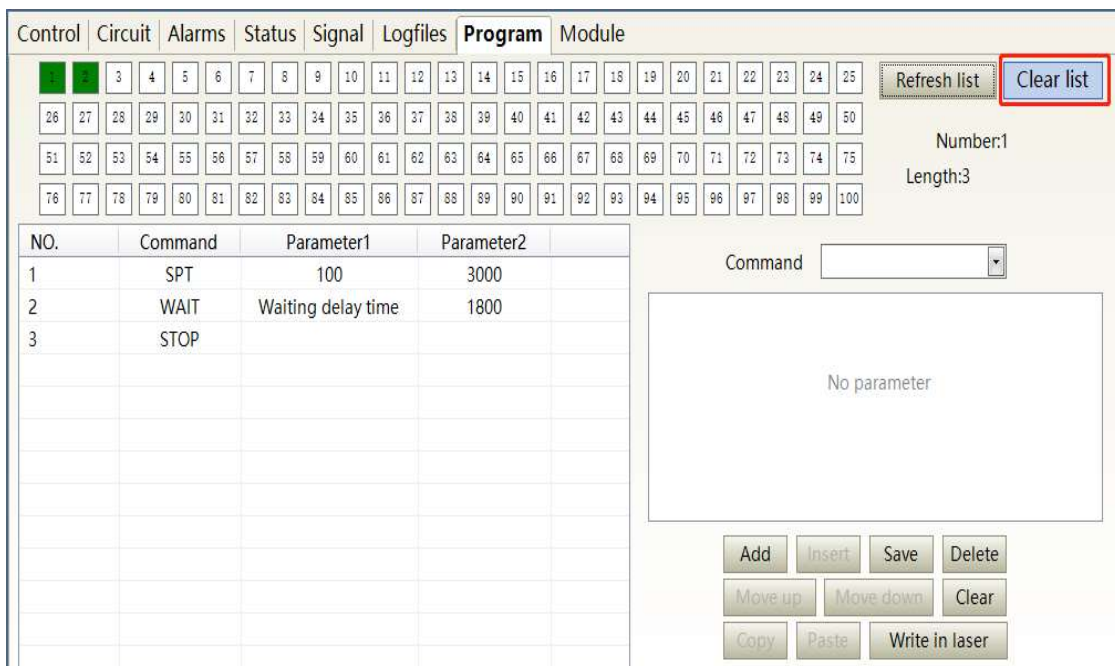

Figure 58 Interface of empty all programming stored in the current laser programming mode

### 8.13.4 Edit Programming

Programming editing when the laser is working in programming mode as shown in Figure 59.

Step 1:left click the pre-edited programming number.

Step 2:select the command under the command type, click ‘Add’.

Step 3:enter the parameters and click ‘Save’. The instruction appears in the left program list immediately.

Step 4:after editing all commands, click ‘Write Laser’.

Step 5:the new programming number will turn green when user re-click the ‘refresher list’ button.  
Write successfully.

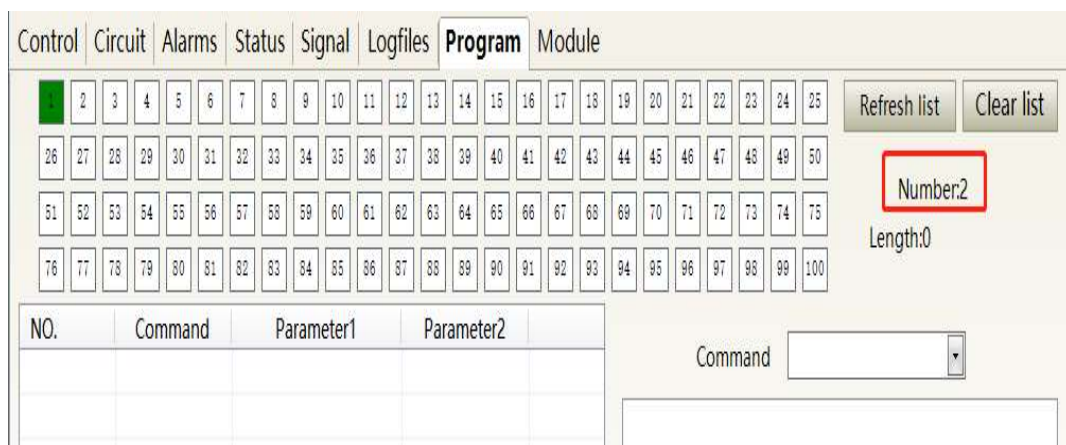

a) Select the pre-edited programming number

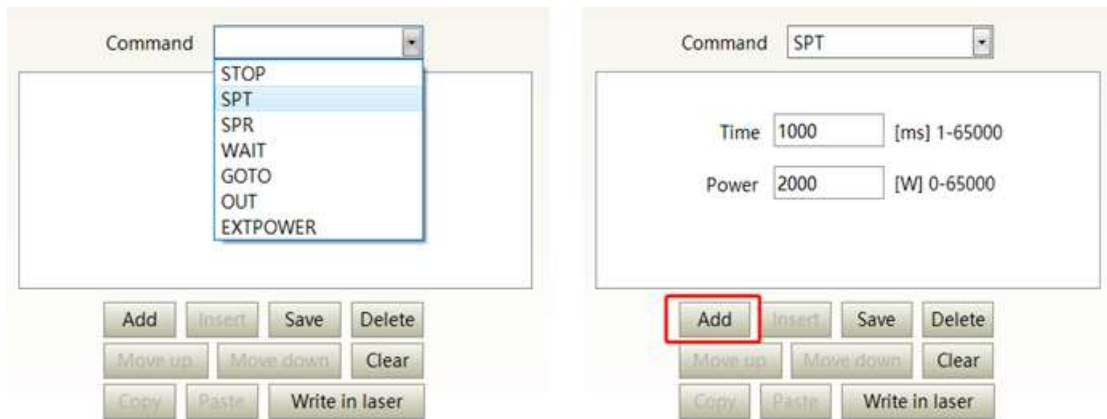

b) Add command type

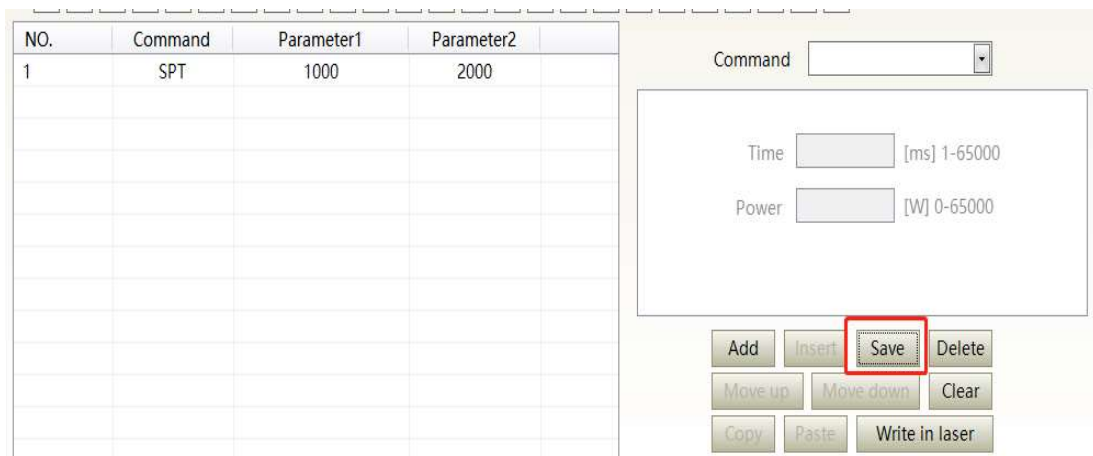

c) Save command

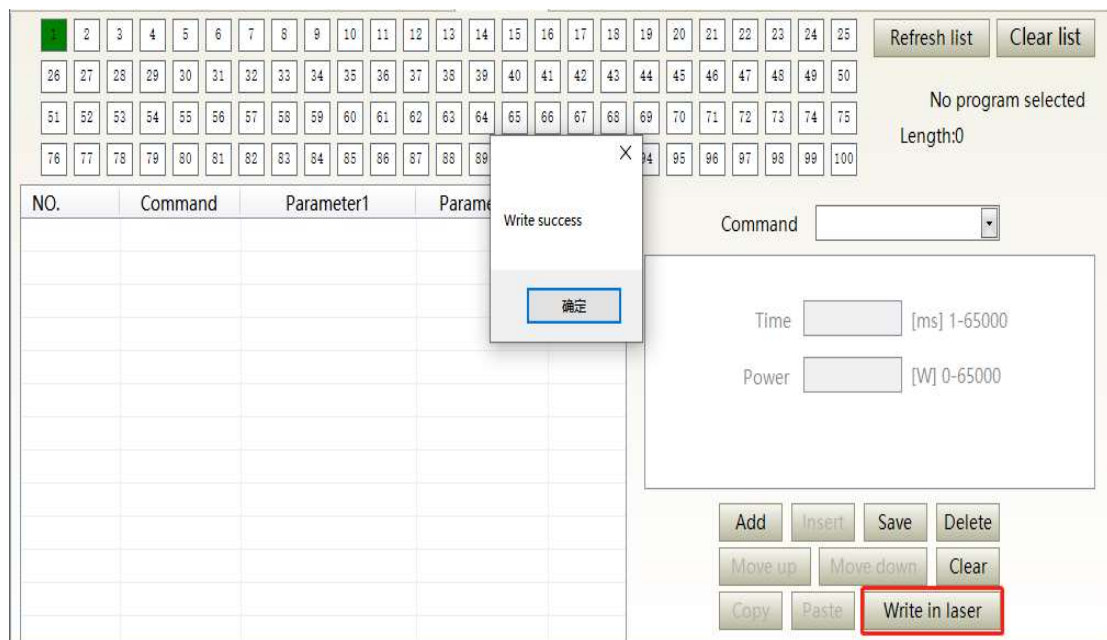

d) Type the command code into laser

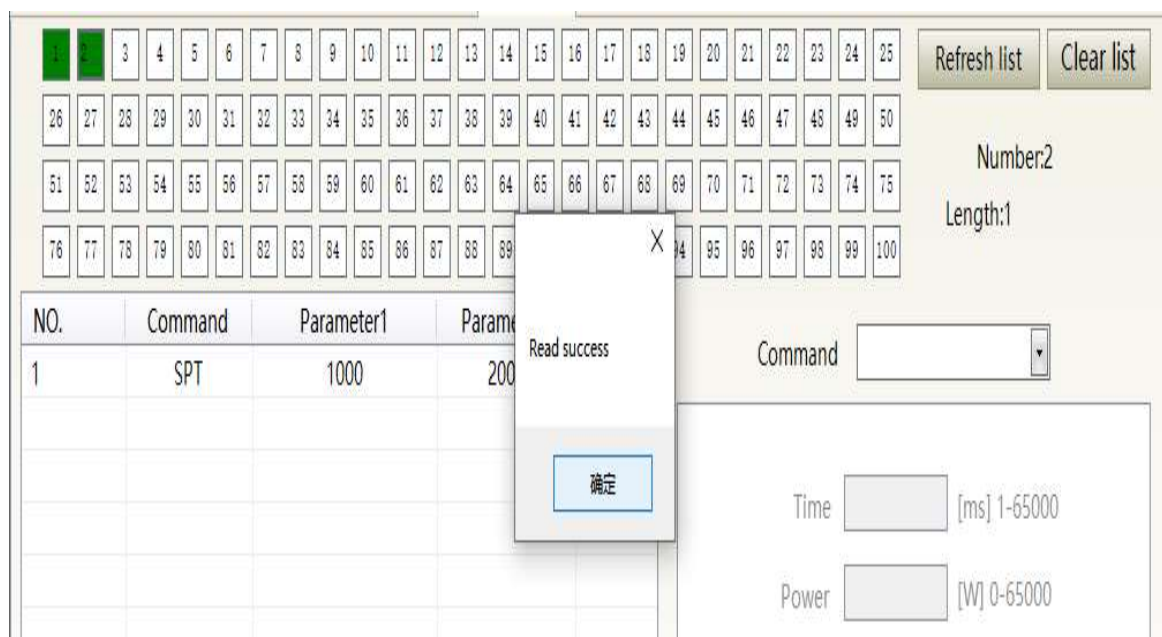

e) Check effectiveness of instruction

Figure 59 A diagram of the programming editing operation in programming mode

### 8.13.5 Command Explanation

Command meaning in laser working status is shown in Table 16

Table 16 command meaning in laser working status

Code (1 Byte)		Parameter1(2 bytes)		Parameter 2 (4 bytes)	Note
1	Stop	None		None	The program end command. the last command must be this command
2	SPT	0~65000 (MS)		0~65000(W)	Change power to 2 in time 1
3	SPR	0~65000 (W/MS)		0~65000(W)	Change power to 2 in power change ratio 1
4	WAIT	1	Wait for sync signal low level	Null	
		2	Wait for sync signal high level	Null	
		3	Wait for sync signal rising	Null	
		4	Wait for sync signal dropping	Null	
		5	Wait time	0~65000ms(integer)	

5	GOTO	0~99	Line	-1	Switch at low sync signal	Jump to different line when comply
		0~99	Line	-2	Switch at high sync signal	Jump to different line when comply
		0~99	Line	0~1000000	Times of jump to subject line	Times of loop jump to subject line
6	OUT	1	SO	1	Sync signal low level output	
				2	Sync signal high level output	
7	EXT Power	1	0~10V			
		2				

## 9 Warranty, Repair and Return

### 9.1 General Warranty

After all the products manufactured are delivered according to the order or specifications, Raycus will guarantee the products to be free from any material and technical problems and ensure that they meet the specifications under Normal use.

Raycus has the right to selectively repair or replace any products with material or technical problems during the warranty period. All products repaired or replaced during the warranty period are guaranteed free warranty only for those products with special problems. Raycus reserves the right to charge the payment for the products with problems under Normal use.

### 9.2 Limitations of Warranty

The warranty does not cover the maintenance or reimbursement of our product of which the problem results from tampering, disassembling, misuse, accident, modification, unsuitable physical or operating environment, improper maintenance, damages due to excessive use or not following the instructions caused by those who are not from Raycus. The customer has the responsibility to understand and follow this instruction to use the device. Any damage caused by fault operating is not warranted. Accessories and fiber connectors are excluded from this warranty.

According to the warranty, client should inform us within 31days after the defect is discovered. This warranty does not involve any other party, including specified buyer, end-user or customer and any parts, equipment or other products produced by other companies.



**WARNING:** It is the customer's responsibility to understand and follow operating instructions in this User Guide and specifications prior to operation-failure to do so may void this warranty. Accessories and fiber connectors are not covered by this warranty.

### 9.3 Service and Repair

This product has no built-in parts for user maintenance, so all repairs should be performed by Raycus technicians.

Any failure of the product during use should be notified to Raycus after-sales personnel in time to troubleshoot the problem.

All repair or replacement products must be placed in the original packaging box provided by Raycus, otherwise any product damage caused by this will not be repaired free of charge by Raycus.

When you receive Raycus products, please check whether the products are intact in time. If there is any abnormality, please contact the carrier or Raycus in time.

**Raycus will continue to develop new products. The product information listed in the manual may be changed without notice. All technical parameters are subject to the contract terms.**

**The above product warranty and service terms of Raycus are for users' reference only, and the formal service and warranty contents are subject to agreement in the contract.**

**Information contained in this document is subject to change without notice.**

---