



Raycus ABP Series High Power Continuous Wave Fiber Laser User Guide

Applicable:

**RFL-1500/1500-ABP
RFL-3000/3000-ABP
RFL-2000/4000-ABP
RFL-6000/6000-ABP**

**RFL-2000/2000-ABP
RFL-4000/2000-ABP
RFL-4000/4000-ABP**

CONTENT

1	SAFETY INFORMATION	2
1.1	SECURITY LABEL	2
1.2	LASER SAFETY GRADE.....	3
1.3	OPTICAL SAFETY.....	3
1.4	ELECTRICAL SAFETY.....	3
1.5	OTHER SAFETY GUIDELINES.....	4
2	PRODUCT DESCRIPTION.....	5
2.1	FEATURES.....	5
2.2	PACKAGE PARTS.....	5
2.3	UNPACKING AND INSPECTION.....	5
2.4	OPERATION ENVIRONMENT.....	6
2.5	ATTENTIONS.....	7
2.6	SPECIFICATIONS.....	7
3	INSTALLATION	9
3.1	DIMENSIONS.....	9
3.2	INSTALLATION REQUIREMENTS.....	12
3.3	COOLING REQUIREMENTS.....	14
3.3.1	<i>Requirements for Cooling Water:</i>	14
3.3.2	<i>Requirements for Delivery Cable Cooling System:</i>	15
3.3.3	<i>Other Requirements:</i>	16
4	USING THE PRODUCT.....	17
4.1	FRONT PANEL.....	17
4.2	REAR PANEL.....	18
4.3	POWER CONNECTION.....	20
4.4	CONTROL INTERFACE DEFINITION.....	22
4.4.1	<i>Safety XP2 24 Pin Interface</i>	23
4.4.2	<i>Hardwire XP1</i>	26
4.4.3	<i>XP3 RS232 Interface</i>	29
4.4.4	<i>XP4 Analog Interface</i>	29
4.4.5	<i>XP5 Ethernet Interface</i>	29
4.5	INTERLOCKING.....	30
4.6	SCHEMATIC DIAGRAM OF THE LASER ELECTRICAL CIRCUIT.....	30
4.7	OPERATION START-UPS SEQUENCES.....	31
5	CONTROL MODE SELECTION	32
5.1	ON MODE.....	33
5.1.1	<i>AD Mode Enable</i>	34
5.1.2	<i>Emission External Control Enable</i>	34
5.1.3	<i>Guide laser (Red Guide Beam) Control</i>	34
5.1.4	<i>Programming Mode</i>	34
5.2	REM MODE.....	34
5.2.1	<i>AD Mode</i>	34
5.2.2	<i>External Control</i>	35
5.2.3	<i>Guide laser Control</i>	35
5.2.4	<i>Programming Mode</i>	35
6	LASER WIRING MODE AND OPERATION STEPS	36
6.1	INTERNAL CONTROL IN ON MODE.....	36
6.2	LASER OPERATING IN EXTERNAL CONTROL MODE.....	36
6.3	IN ON MODE, THE LASER EMISSION POWER IS EXTERNALLY CONTROLLED BY ANALOG SIGNAL.....	37
6.4	LASER OPERATING IN PROGRAMMING MODE.....	38
6.5	SET THE POWER ANALOG QUANTITY IN REM MODE TO CONTROL THE LASER EMISSION.....	39

6.6	POWER COMMUNICATION SETTING IN REM MODE	40
6.7	PROGRAMMING MODE IN REM MODE.....	41
7	RS232 AND INTERNET COMMUNICATION COMMANDS	43
7.1	PORT CONFIGURATION	43
7.2	LASER COMMUNICATION PROTOCOL (ETHERNET PORT & SERIAL PORT).....	43
8	RAYCUS LASER CONTROL SYSTEM INSTRUCTIONS	48
8.1	MAIN INTERFACE OF THE SOFTWARE.....	48
8.2	MULTI-LASER CONTROL	48
8.2.1	<i>Add/Delete Laser.....</i>	<i>49</i>
8.2.2	<i>Delete Laser</i>	<i>50</i>
8.2.3	<i>Modify Laser IP</i>	<i>50</i>
8.3	MAIN WORKING STATUS DISPLAY	51
8.3.1	<i>Laser's Cumulative Operating Time Display Area</i>	<i>52</i>
8.3.2	<i>Laser Working Status Display Area.....</i>	<i>52</i>
8.3.3	<i>Laser Power-up, Mode Selection, Laser Emission Control Area</i>	<i>53</i>
8.3.4	<i>Programming Mode Test Area</i>	<i>54</i>
8.3.5	<i>Power Slow Rise & Down Parameter Setting Area</i>	<i>55</i>
8.3.6	<i>Laser Emission Parameters Read the Settings Area.....</i>	<i>56</i>
8.4	LASER PARAMETER DISPLAY AREA.....	57
8.5	ALARM TYPE DISPLAY AREA.....	57
8.6	RING LIGHT PARAMETERS SETTING.....	58
8.7	RAYCUS LASER CONTROL SOFTWARE OPERATING MODE SELECTION.....	59
8.8	LANGUAGE	60
8.9	AUTHORIZATION (TIME-LIMITED LOCKING).....	60
8.9.1	<i>Authorization in User Mode</i>	<i>60</i>
8.9.2	<i>Authorization in Authorization Mode</i>	<i>61</i>
8.10	ABOUT	63
8.11	LOG (IN DIAGNOSTIC MODE).....	64
8.11.1	<i>Download Log</i>	<i>64</i>
8.11.2	<i>Download Record of Historical Fault</i>	<i>64</i>
8.11.3	<i>Downloaded File Address.....</i>	<i>65</i>
8.12	MODULE PARAMETERS (IN DIAGNOSTIC MODE)	65
8.13	PROGRAMMING SETTINGS (WAVEFORM EDITING).....	66
8.13.1	<i>View the Number of Wave Bars Inside the Current Laser</i>	<i>66</i>
8.13.2	<i>Check Waveform Content.....</i>	<i>66</i>
8.13.3	<i>Empty All Waveforms</i>	<i>67</i>
8.13.4	<i>Edit Waveform.....</i>	<i>67</i>
8.13.5	<i>Command Explanations.....</i>	<i>69</i>
9	WARRANTY, REPAIR AND RETURN.....	71
9.1	GENERAL WARRANTY	71
9.2	LIMITATIONS OF WARRANTY.....	71
9.3	SERVICE AND REPAIR.....	71

Figure List

Figure 1 Dimensions of RFL-1500/1500-ABP	9
Figure 2 Dimensions of RFL-4000/4000-ABP	10
Figure 3 Dimensions of RFL-6000/6000-ABP	11
Figure 4 External dimensions of the RFL-HQBH fiber delivery cable connector	12
Figure 5 External dimensions of the RFL-QD fiber delivery cable connector.....	12
Figure 6 Product top lifting rings and bottom level adjustment casters	13
Figure 7 Schematic diagram of laser cooling system connection.....	15
Figure 8 Front panel.....	17
Figure 9.-View of laser rear panel.....	20
Figure 10 Power cords of different models	21
Figure 11 Power cord plug and socket.....	21
Figure 12 Control signal connectors.....	23
Figure 13 Mod signal schematic diagram.....	24
Figure 14 Internal schematic diagram.....	25
Figure 15 Recommended wiring diagram	25
Figure 16 Internal circuit diagram	25
Figure 17 Recommended wiring diagram.....	26
Figure 18 Recommended wiring diagram	26
Figure 19 XP2 Remote main power supply wiring diagram	26



Table List



Table 1 Operation conditions for the laser.....	6
Table 2 Product specifications	7
Table 3 Water cooling requirements	14
Table 4 Definition and parameter requirements of AC interface	22
Table 5 Safety XP2 24 pin interface definition.....	23
Table 6 XP1 Hardwire interface definition.....	27
Table 7 XP3 serial interface definitions.....	29
Table 8 XP4 analog interface definitions.....	29
Table 9 XP5 communication interface definition.....	29
Table 10 Control modes and their subsequent operating methods.....	32
Table 11 Laser protocol contents and command examples.....	43
Table 12 The laser main display content and meanings.....	51
Table 13 The laser main display area clarification	53
Table 14 Laser power-on, mode selection, laser emission control display area explanation.....	54
Table 15 Laser operating mode and explanation	59
Table 16 Command explanations in laser working status.....	69

1 Safety Information

Thank you for choosing Raycus Fiber Laser Products, hereinafter refers as the Product/Products or Lasers/Laser. This users' manual provides you with important safety, operation, maintenance, and other relevant information. Please read the manual carefully before using the product. To ensure safe operation and optimum product operation, please observe the following cautions and warnings as well as other information within this manual.

1.1 SECURITY LABEL

	<p>WARNING: May cause serious injury to the person or even endanger the safety of life.</p>
	<p>CAUTION: May cause general injury to the person or damage to products or equipment.</p>

<div data-bbox="185 1137 486 1283"> <p>AVOID EXPOSURE VISIBLE AND/OR INVISIBLE LASER RADIATION IS EMITTED FROM THIS APERTURE Per GB 7247.1-2012/IEC 60825-1:2007</p> </div> <p>English label</p> <div data-bbox="185 1323 486 1469"> <p>激光窗口 避免受到从本窗口射出的 激光辐射的照射 GB 7247.1-2012/IEC 60825-1:2007</p> </div> <p>Chinese label</p>	<div data-bbox="624 1137 925 1283"> <p>MAX AVERAGE OUTPUT POWER:12000W CW WAVELENGTH RANGE:900-1200nm DANGER-VISIBLE AND/OR INVISIBLE LASER RADIATION AVOID EYE OR SKIN EXPOSURE TO DIRECT OR SCATTERED RADIATION CLASS 4 LASER PRODUCT Per IEC 60825-1:2014</p> </div> <p>English label</p> <div data-bbox="624 1323 925 1469"> <p>最大平均输出功率:12000W CW 波长范围:900-1200nm 可见及不可见激光辐射 避免眼或皮肤受到直射或散射辐射的照射 4类激光产品 GB 7247.1-2012/IEC 60825-1:2007</p> </div> <p>Chinese label</p>	<div data-bbox="1090 1137 1391 1283"> <p>MAX AVERAGE OUTPUT POWER:1mW WAVELENGTH RANGE:600-700nm VISIBLE LASER RADIATION DO NOT STARE INTO BEAM OR EXPOSE USERS OF TELESCOPIC OPTICS CLASS 2 LASER PRODUCT Per IEC 60825-1:2014</p> </div> <p>English label</p> <div data-bbox="1090 1323 1391 1469"> <p>最大平均输出功率:1mW 波长范围:600-700nm 可见激光辐射 勿直视或通过光学仪器直接观看光束 2M 类激光产品 GB 7247.1-2012/IEC 60825-1:2007</p> </div> <p>Chinese label</p>
<p>1. Laser Emission Aperture</p>	<p>2. Class 4 Laser Product</p>	<p>3. Class 2M laser Product – 1 mW Guide laser</p>
		
<p>4. CE Certification</p>	<p>5. Product Nameplate</p>	<p>6. Laser Radiation Hazard</p>

		
<p>7. Electrical Hazard</p>		

1.2 Laser Safety Grade

According to European Standard EN 60825-1, Clause 9, this series of laser products are Class 4 laser products. This product emits laser radiation at a wavelength of 1080 nm or around 1080 nm, and the average laser power of the products listing in this User Guide radiated from the fiber delivery cable is ranged from 3000W to 12000W (depending on the product model). Either directly or indirectly being exposed to high power laser radiation will bring permanent damage to the eye or skin. Even though the radiant laser is not visible at the wavelength of about 1080nm, the beam will cause irreparable damage to the retina or cornea, so appropriate and certified laser safety glasses must be worn throughout the laser emitting.

	<p>WARNING: Users must wear appropriate laser goggles when operating this device. The laser goggles should be selected according to the range of wavelength emitted from this product. Users must ensure that the protect range of laser goggles over the entire range of laser wavelengths. It is forbidden to watch the laser fiber delivery connector during laser emission.</p>
---	--

1.3 Optical Safety

The dust on the end of the fiber delivery connector may bring damage to the lens or the entire laser device.

	<p>CAUTION: DO NOT emit the laser when the black plastic protective cap is not removed, otherwise the lens or the crystal will be damaged.</p>
---	---

1.4 Electrical Safety

- a) Ensure that the product is effectively grounded, and the installation environment is safe and reliable.



WARNING: The disconnection of the product grounding will cause the product shell to become electrified, which may result in personal injury to the operator.

- b) Ensure that the AC voltage is supplied normally.



CAUTION: Wrong wiring mode or power supply voltage will cause an irrecoverable damage to the laser device.

1.5 Other Safety Guidelines

- a) **DO NOT** watch the fiber delivery connector of the product directly by anytime when the product is powered on.
- b) **DO NOT** use the product in a dark or dim place.
- c) If the product is used in a manner not specified in this document, the resulted impairment to the laser will not be covered by the warranty.
- d) There are no user serviceable parts, equipment, or assemblies inside the product. All service and maintenance shall be performed and conducted by the Raycus engineer or authorized personnel. In order to prevent electric shock, **DO NOT** break the seal or remove the shell. Failure to comply with this instruction and the resulted impairment to the laser will not be covered by the warranty.

2 Product Description

2.1 Features

Fiber lasers are compact and ready to use in comparison with conventional laser products, featuring higher electrical to optical conversion efficiencies, lower power consumption and better beam quality. Furthermore, thanks to its flexible laser emission design by using a shielded optical fiber, it can be easily and safely integrated into a varies of laser application systems.

Main features:

- a) High beam quality;
- b) Adjustable output beam;
- c) Center/ring power adjusted independently;
- d) High reliability
- e) Maintenance-free operation;
- f) High electrical-optical efficiency;
- g) Convenient control interface;
- h) Fast modulation.

Typical Applications:

- a) Power battery welding and high anti mental welding;
- b) Scientific research.

2.2 Package Parts

Please refer to the enclosed Package Parts List to cross check what accessories should be contained in the packing box.

2.3 Unpacking and Inspection

Through the specially designed packaging materials and cabinets, Raycus ensures that the lasers are fully protected during the transportation. Nevertheless, in order to prevent any unpredictable situation during transportation, the users still need to carefully check whether the package is correctly handled before unpacking, and whether there is any damage or suspicious appearance such as collision, crack or water stain on the outside of the box. Once users find that there is an abnormality in the external cabinet, please inform Raycusat once.

Please double check if each listed content is inside the package; and contact Raycus as soon as possible if there is any unusual issue.

Take extra care when removing the product from the package and try to make the fiber delivery cable

with its connector staying away from collision and vibration. Please **DO NOT** distort, bend, or pull the delivery cable when unpacking the device; and avoid any collision to the quartz or protective cap of laser emission.

	<p>CAUTION: The fiber delivery cable and its connector are precise optic instrument, any vibration or impact to the fiber delivery cable or connector, twist or excessive bend will damage the product.</p>
---	--

2.4 Operation Environment

The required operation conditions are listed as in the Table 1:

Table 1 Operation conditions for the laser

Model	1500/1500	2000/2000	3000/3000	2000/4000	4000/2000	4000/4000	6000/6000
Supply Voltage	Three-phase four-wire, AC 323V~AC 437V, 50/60Hz (with PE)						
Power Supply Capacity	> 15 kVA	> 18 kVA	> 25 kVA	> 25 kVA	> 25 kVA	> 35 kVA	>50 kVA
Water Cooling Flow	> 35 L/min	> 35 L/min	> 52 L/min	> 52 L/min	> 52 L/min	> 64 L/min	> 94 L/min
Installation Environment	Flat, no vibration nor impact						
Ambient Temperature	10°C ~ 40 °C						
Relative Humidity	<70%						

- a) Make sure the product is properly grounded before use.
- b) The fiber delivery cable connector is well connected with the fiber optic cable (delivery cable). Please inspect the fiber delivery cable connector carefully for dust or other contaminations. Use appropriate lens cleaning paper to remove the dust before laser emission.
- c) Failure to follow the instructions when using the laser may cause malfunction or damage.
- d) DO NOT install the fiber delivery cable connector during laser emission.
- e) DO NOT watch the fiber delivery cable connector lens directly if the laser is powered on. MUST wear the appropriate protective goggles all the time when operating the laser.

TIPS:

Install the laser in an air-conditioned environment will offer the product to benefit a longer life and better performance.

2.5 Attentions

- a) Make sure that the main power supply of AC 380V correctly connected. Wrong connection will damage the product.
- b) It is important to keep the fiber delivery cable connector clean, otherwise it will damage the product.
- c) Please cap the fiber delivery cable connector when it is not in use. DO NOT touch the top lens of the connector at any time. Use appropriate lens cleaning paper to clean it when any dust or dirt is noticed.
- d) Keep the cap safety in the storage box when using the product. To avoid dust inside the cap that may pollute the lens of the connector, make sure the opening direction of the cap is put down.
- e) Failure to follow those above instructions may cause laser power loss, such loss will not be covered by warranty.

2.6 Specifications

Table 2 Product specifications

Optical Characteristics								Test condition
Product	1500/ 1500	2000/ 2000	3000/ 3000	2000/ 4000	4000/ 2000	4000/ 4000	6000/6000	
Emission Power	3kW	4kW	6kW	6kW	6kW	8kW	12 kW	/
Center emission power	1.5 kW	2 kW	3 kW	2 kW	4 kW	4 kW	6 kW	
Ring emission power	1.5 kW	2 kW	3 kW	4 kW	2 kW	4 kW	6 kW	
Operation Mode	Continuous Wave / Modulated							/
Polarization	Random							/
Emission Power Range	10% ~ 100%							/
Emission Wavelength	1080 ± 5 nm							Nominal Emission Power
Emission Power Instability	±1.5%							Nominal Emission Power; Continuous running time: greater than 5hrs; operating temperature : 25°C
Modulation Frequency	50~5000Hz				50~2000Hz			Nominal Emission Power
Red GuideLaser Power	0.5mW~1mW							/
Fiber delivery cable connector	IHQB					QD		/
Center Beam Quality *(86%) (BPP,mm•mrad)	<2.2 (@50um) / <4 (@100um)							Nominal Emission Power
Center beam mrad*(86%) (mrad)	<90(@50um) / <90 (@100um)							Nominal Emission Power

Ring Beam Quality*(86%) (BPP,mm•mrad)	<7.0(@150um) / <17 (@300um)						Nominal Emission Power	
Ring beam mrad*(86%) (mrad)	<100(@150um) / <110 (@300um)						Nominal Emission Power	
Center beam Fiber Core Diameter (μm)	50、100 um、 Customizable				100 um		Customizable	
Ring beam Fiber Core Diameter (μm)	150、300 um、 Customizable				300 um		Customizable	
Fiber Delivery Cable Length	20 m						Customizable	
Electrical Characteristics								
Operating Voltage	Three-phase four-wire system AC 340V ~ 420V, 50/60Hz (with PE)						/	
Max.Power Consumption	9kw	11.5kw	17.5kw	17.5kw	17.5kw	23kw	34.5kw	/
Way to Control	Serial Communication / AD						/	
Other Characteristics								
Dimension W×H×D	670×990×1160mm		900×960×1160mm			1200×960×1160mm		Includes casters and rings, without warning lights
Weight	<250kg		<360kg		<400kg	<500kg		Air conditioning included
Operating Ambient Temperature	10~40 °C						/	
Humidity	<70 %						/	
Storage Temperature	-10~60 °C						/	
Cooling Method	Water Cooling						/	

3 Installation

3.1 Dimensions

The mechanical dimensions of RFL-1500/1500-ABP, RFL-2000/2000-ABP, RFL-3000/3000-ABP, RFL-2000/4000-ABP, RFL-4000/2000-ABP, RFL-4000/4000-ABP and RFL-6000/6000-ABP are shown as follows:

- a) The dimensions of the RFL-1500/1500-ABP, RFL-2000/2000-ABP are shown in Figure 1 (taking RFL-1500/1500-ABP as an example).

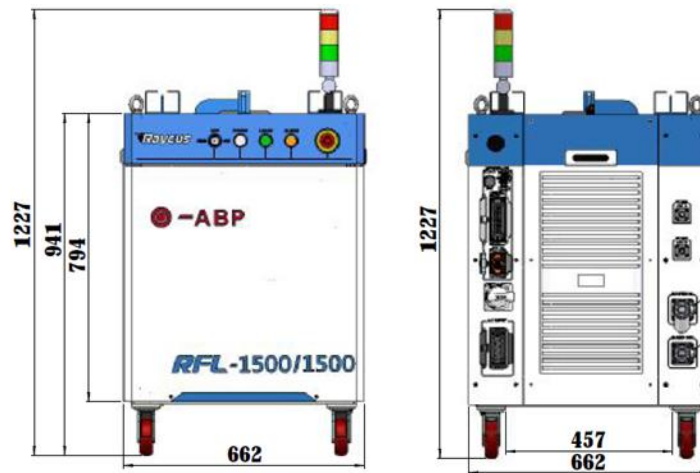

Figure 1.a - Front and rear view

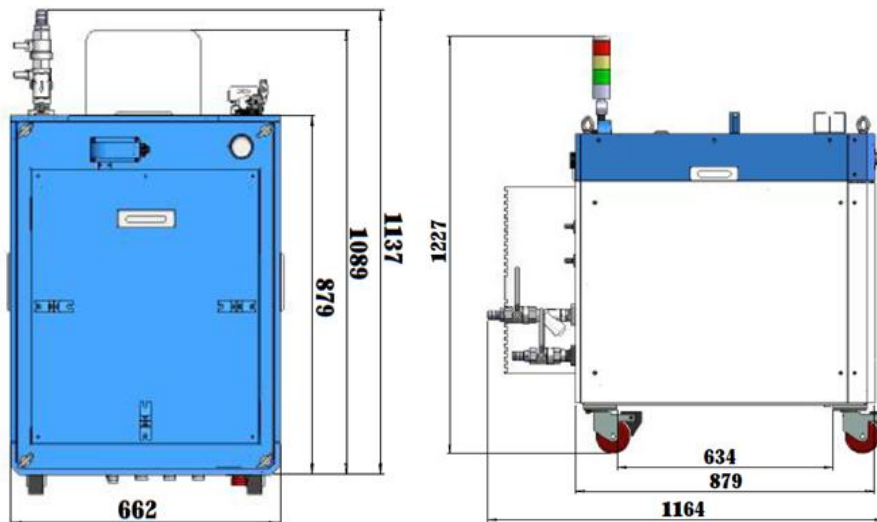

Figure 1.b - Top and leftside view of the product

Figure 1 Dimensions of RFL-1500/1500-ABP

Those two models of RFL-1500/1500-ABP and 2000/2000-ABP share a same cabinet, henceforth the same dimensions of 670×990×1160mm (width × depth × height, including casters and rings, excluding the status lamps), and the weight is about 250kg for RFL-1500/1500-ABP, and about 280kg for RFL-2000/2000-ABP.

- b) The dimensions of the RFL-3000/3000-ABP, RFL-2000/4000-ABP, RFL-4000/2000-ABP, RFL-4000/4000-ABP are shown in Figure 2 (taking RFL-4000/4000-ABP as an example)

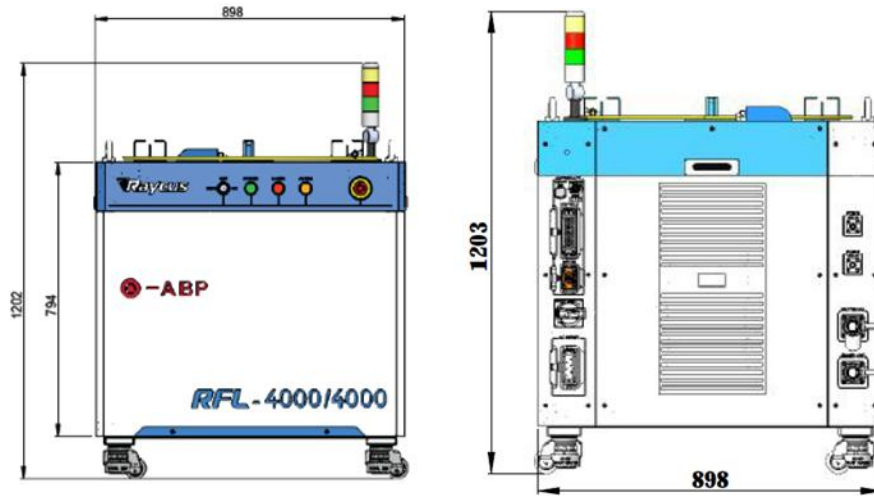

Figure 2.a - Front and rear view

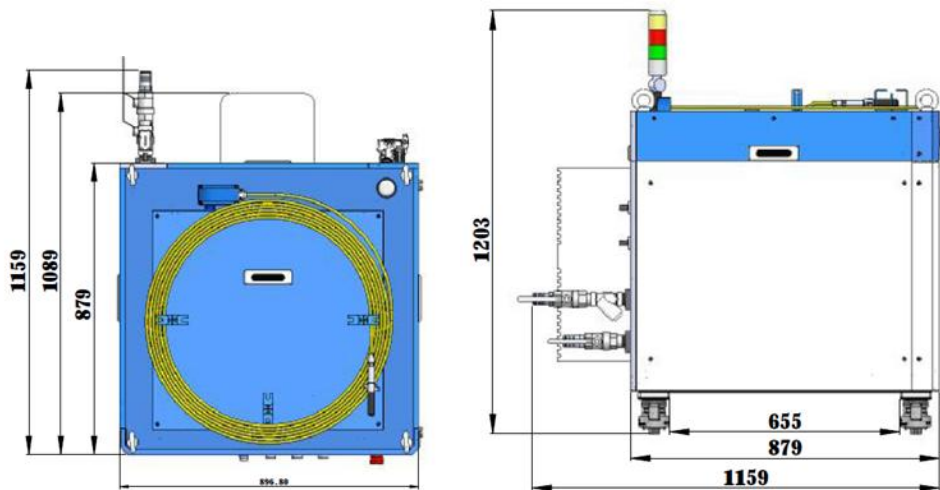

Figure 2.b -Top and left side view

Figure 2 Dimensions of RFL-4000/4000-ABP

RFL-3000/3000-ABP , RFL-4000/2000-ABP , RFL-2000/4000-ABP and RFL-4000/4000-ABP share a same cabinet, and henceforth the same dimensions of 900×960×1160 mm (width × depth × height, casters and rings, excluding alarm lights), and the weight is less than 400kg for all four types of laser.

- c) dimensions of the RFL-6000/6000-ABP are shown in Figure 3:

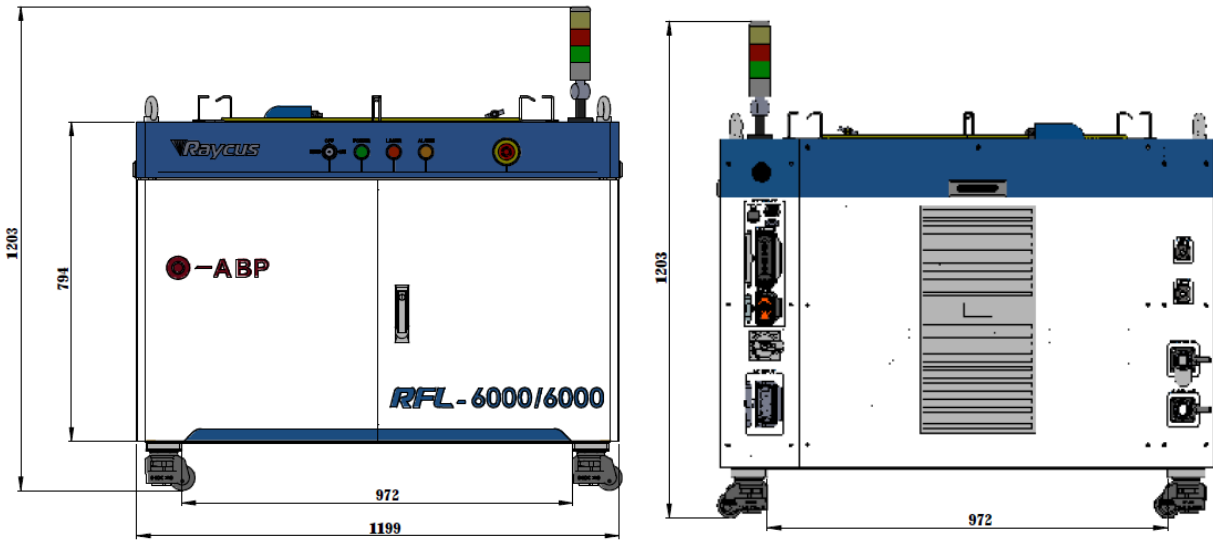

Figure 3.a - Front and rear view

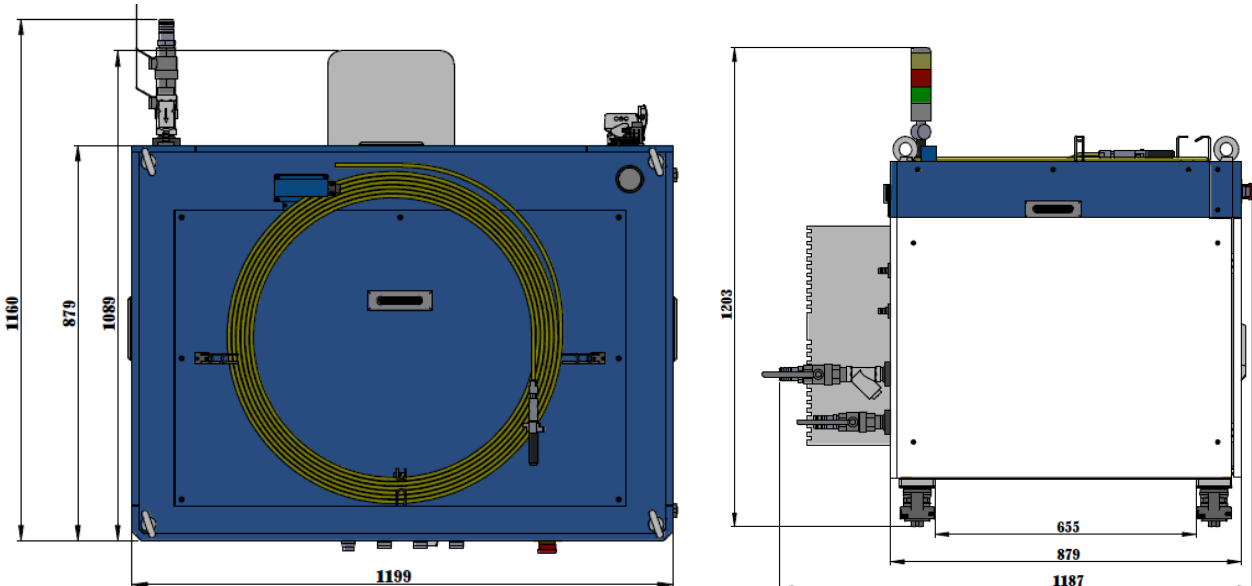

Figure 3.b - Top and left side view

Figure 3 Dimensions of RFL-6000/6000-ABP

RFL-6000/6000-ABP share a cabinet, and henceforth the same dimensions of 1200×960×1160 mm (width × depth × height, casters and rings, excluding alarm lights), and the weight is about 500kg for RFL-6000/6000-ABP.

The type and dimensions of RFL-1500/1500-ABP , RFL-2000/2000-ABP , RFL-3000/3000-ABP , RFL-2000/4000-ABP , RFL-4000/2000-ABP , RFL-4000/4000-ABP , RFL-6000/6000-ABP's fiber delivery cable and cable connector are as follows:

- a) RFL-1500/1500-ABP, RFL-2000/2000-ABP, RFL-3000/3000-ABP, RFL-2000/4000-ABP, RFL-4000/2000-ABP , RFL-4000/4000-ABP uses the RFL-HQBH model cable connector, and the external dimensions of the cable connector are shown in Figure 4:

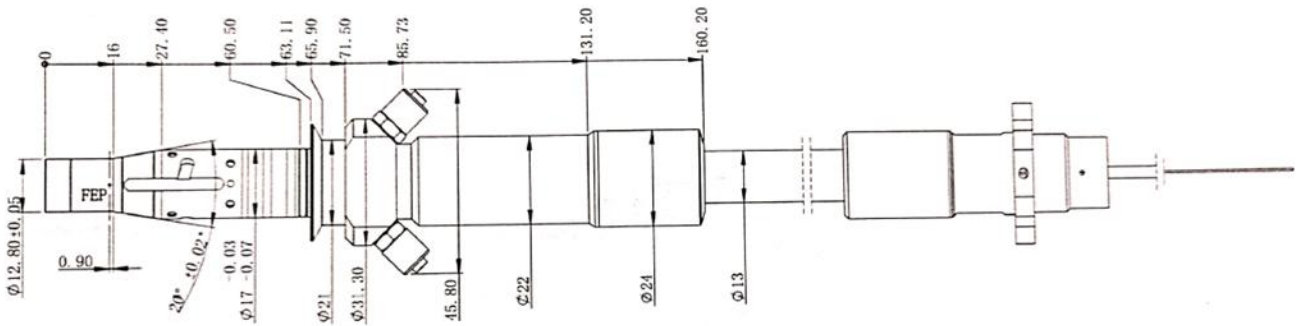

Figure 4 External dimensions of the RFL-HQBH fiber delivery cable connector

- b) RFL-6000/6000-ABP uses the RFL-QD model cable connector, and the external dimensions of the output optical cable connector are shown in Figure 5:

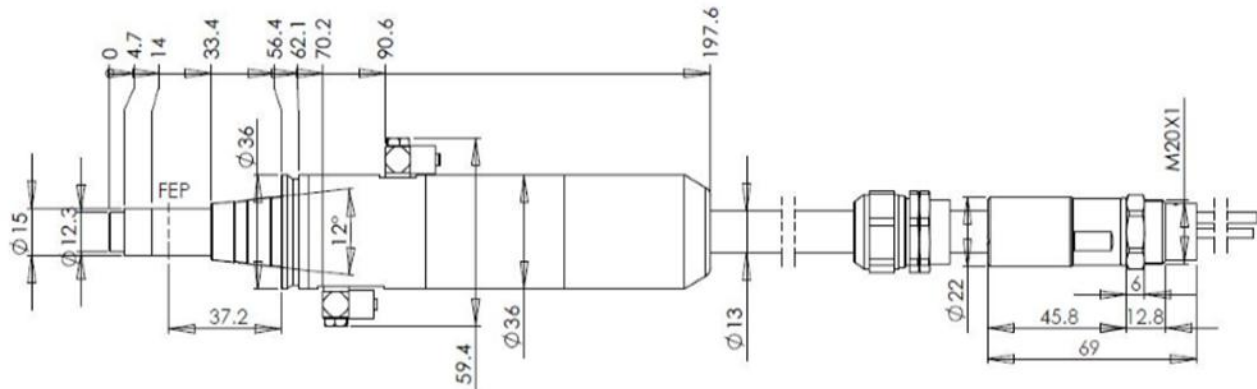

Figure 5 External dimensions of the RFL-QD fiber delivery cable connector

NOTE:

- The dimensions in the above figures are in the unit of mini-meter (mm).
- Before the laser is powered on, make sure that the two copper contacts (interlock pins) on the fiber connector are shorted well, otherwise the laser will not work properly.
- Before installing the fiber delivery cable connector into the laser processing head, the lens of the fiber delivery cable must be inspected carefully.
- If the fiber delivery cable lens is dirty, the lens must be cleaned well. It is forbidden to disassemble the protective lens by anyone other than staff of Raycus or Raycus authorized personnel, otherwise the warranty will be invalidated.

3.2 Installation Requirements

- Place the laser horizontally in a suitable position and fix it as necessary;
- Before the laser is powered on, check if the power supply has the correct voltage (AC 323V ~ 437V, 50/60Hz, see Table 2 Product Technical Data Sheet for details), and the grounding line (PE) shall be well grounded all time during powering on;

- c) Connect the power cable and control cable to the product when power supply is OFF;
- d) Connect the cooling system to the laser and output optical cable connector according to the water inlet and outlet signs;
- e) Please check the laser fiber delivery connector and make sure to clean it before installing it in the equipment;
- f) DO NOT step on, squeeze, or excessively bend the protective tube during the installation of the output optical cable to avoid damage to the optical fiber;
- g) In the process of installing the fiber delivery connector, ensure the cleanliness of the surrounding environment (DO NOT use electric fans to dissipate heat when it is hot in summer to avoid large dust in the air);
- h) The minimum bending diameter of the laser transmission cable in non-working conditions such as transportation and storage shall not be less than 60cm. When the laser is emitting, the minimum bending diameter shall not be less than 40cm;
- i) Users can use the four rings on the top of the product to carry the product or the four casters at bottom to move it. As Figure 6, and MUST check that the rings are firmly installed and that the casters are fully active before lifting the laser.

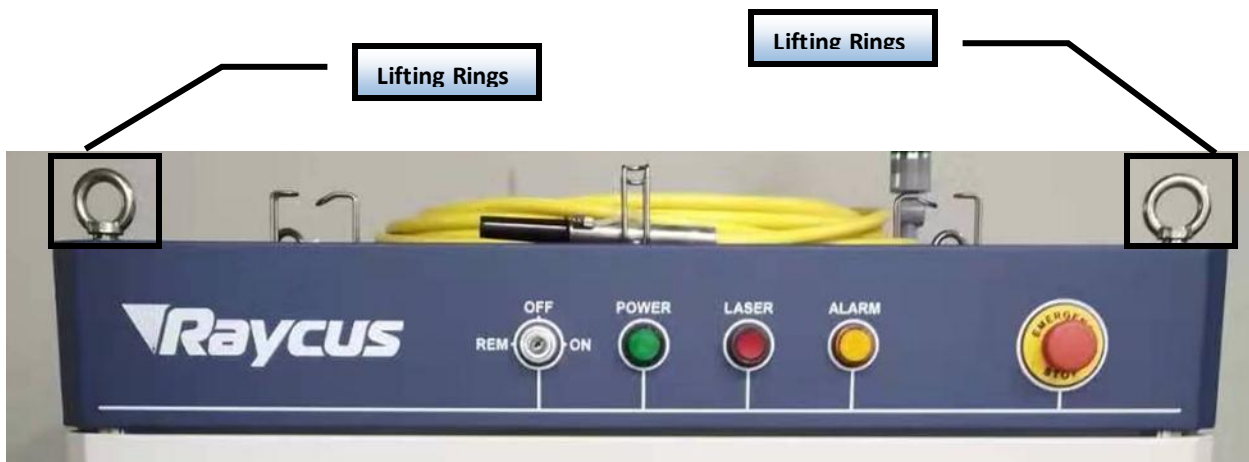

Figure 6.a - Lifting Rings (RFL-4000/4000-ABP as an example)

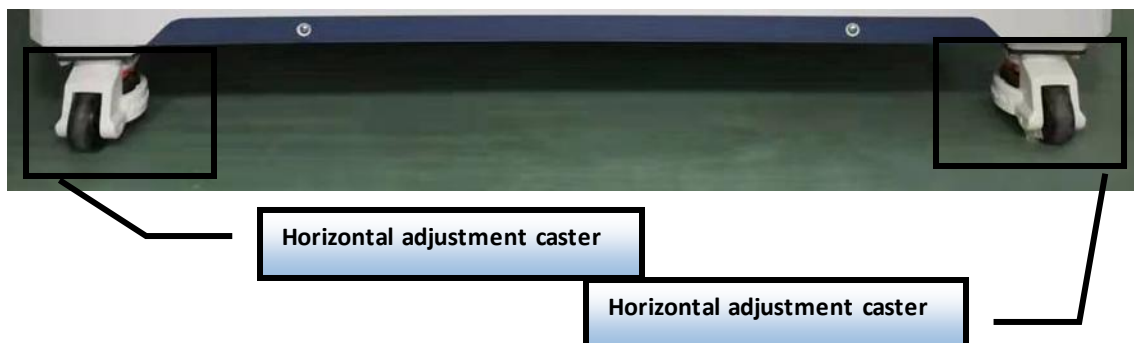





Figure 6.b - Leveling casters (RFL-40000/40000-ABP as an example)

Figure 6 Product top lifting rings and bottom level adjustment casters

	<p>CAUTION: All the cables can only be connected when power supply is off. Hot plug may damage the device.</p>
---	---

	<p>CAUTION:</p> <ul style="list-style-type: none"> a) The placement of the laser delivery cable should be as natural as possible, and the delivery cable should not be twisted; b) If the coil diameter of the delivery optical cable is too small, it will damage the laser.
---	--

	<p>CAUTION:</p> <ul style="list-style-type: none"> a) In the process of installation and disassembly, please handle the laser fiber delivery connector gently, and DO NOT subject it to vibration; b) Before installing the laser fiber delivery connector, ensure that the optical lens and laser processing head cavity are clean and free of pollution.
---	--

3.3 Cooling Requirements

Table 3 Water cooling requirements

Model	1500/1500	2000/2000	3000/3000	2000/4000	4000/2000	4000/4000	6000/6000
Cooling Capacity	≥ 9 kW	≥ 12 kW	≥ 18 kW	≥ 18 kW	≥ 18 kW	≥ 24 kW	≥ 36 kW
Min. Flow Rate	>35 L/min	>35 L/min	>52 L/min	>52 L/min	>52 L/min	>64 L/min	>94 L/min
Max. Input Pressure	4 ~ 6 Bar						
Hose Inner Diameter	Φ25 mm			Φ32 mm			

3.3.1 Requirements for Cooling Water:

- a) The cooling water connection of the laser is shown in Figure 7, and the arrow direction represents the flow direction
- b) The cooling water uses the pure water, may use the drinking pure water.
- c) In order to prevent the growth of mold that may lead to water blockage of the product, adding alcohol solution to about 10% portion of the total volume is recommended.
- d) If ambient temperature is between -10°C and 0°C, it is recommended to use the 30% portion volume alcohol, and replace it by every 2 months entirely.

- e) If the ambient temperature is below -10°C , the cooling system (chiller) with both heating and cooling functions must be activated, and shall keep it in full-time operation by 24 hours to avoid the fiber delivery cable connector and modules inside the product that containing the always waterways from freezing.

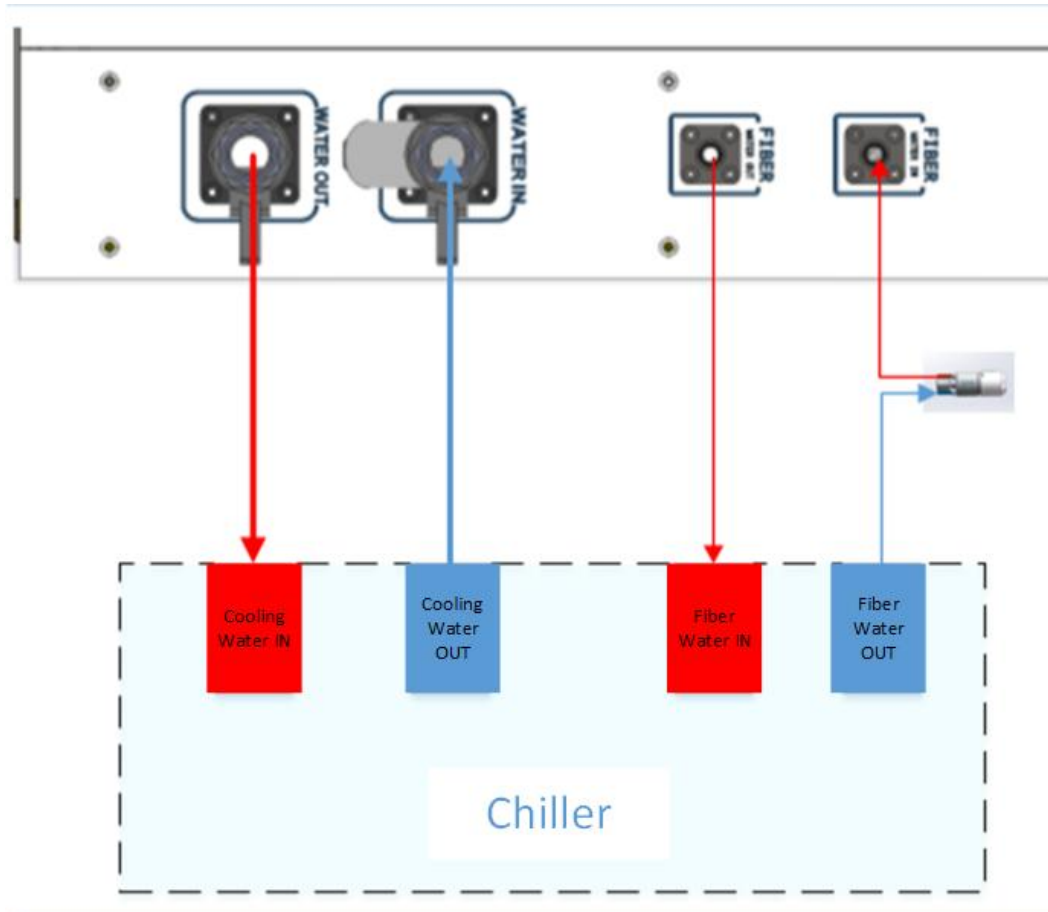

Figure 7 Schematic diagram of laser cooling system connection

3.3.2 Requirements for Delivery Cable Cooling System:

- Water flow requirements:
- RFL-HQBH model fiber delivery cable: 1.5L~2.0 L/min
- RFL-QD model fiber delivery cable: 2.5~3.0 L/min.
- Pressure of liquid flow: $< 0.6 \text{ MPa}$ at the inflow.
- Type of liquid exchange junction: Two-Touch Fitting M5 to $\phi 6 \text{ mm}$.
- Type of tube: outer diameter $\phi 6 \text{ mm}$; inner diameter $\phi 4 \text{ mm}$.
- Direction of cooling liquid: unidirectional; connect the tube with the water-pipe strictly according to direction shown on the layer of the tube.
- Type of liquid: de-ionized water, condensed water, purified water; it is recommended to replace the coolant once a month, not exceeding two months at most.

- i) PH value of liquid: 5.5 ~ 9.
- j) Filter element/cartridge is needed for the cooling system, and the size of the solid residual particles should be $\leq 100 \mu\text{m}$; replace the filter element/cartridge once a month.
- k) Maximum temperature of liquid: 45 °C.
- l) Minimum temperature of liquid: 5 °C above the saturated dew-point.
- m) Additive to the liquid: satisfies the requirements of PH value and size of solid residual particles as above.
- n) Radius of the bending of the armored pipe: off-work state (i.e., transportation and reservation): minimum radius of bending $\geq 30 \text{ cm}$; in-work state: minimum radius of bending $\geq 20 \text{ cm}$.
- o) Long-term vibration $< 2 \text{ G}$; Impact $< 10 \text{ G}$.

3.3.3 Other Requirements:

- a) When initiating the cooling system before using the product each time, check the entire water system and joints to prevent the water leakage. The external water pipe must be installed and connected according to the water inlet (IN) and water outlet (OUT) identified on the rear panel of the product. Otherwise, the product may not work properly.
- b) If the product is not used for a long time, the cooling water inside the cooling system and the product should be drained totally, and then both the inlet and outlet must be covered with proper caps. Otherwise, the product may be damaged due to the frozen.
- c) Please use compressed gas below 0.5 MPa when draining the water from the product. Failure to do so may cause permanent and irrecoverable damage to the cooling system.



CAUTION:

- a) Set the water temperature of the cooling system correctly according to the ambient temperature. If the water temperature was set too high, it will result in the product de-functioning. If the water temperature was set too low, it will cause condensation inside the product or the laser fiber delivery cable, which will cause damage to the product as well;
- b) Before turning on the product, the cooling system must be working properly and the water temperature should be suitable for the temperature.

4 Using the Product

 Please visit Raycus official website to download the latest Raycus Laser Control Software and its user manual as well. Website: <http://www.raycuslaser.com>

4.1 Front Panel

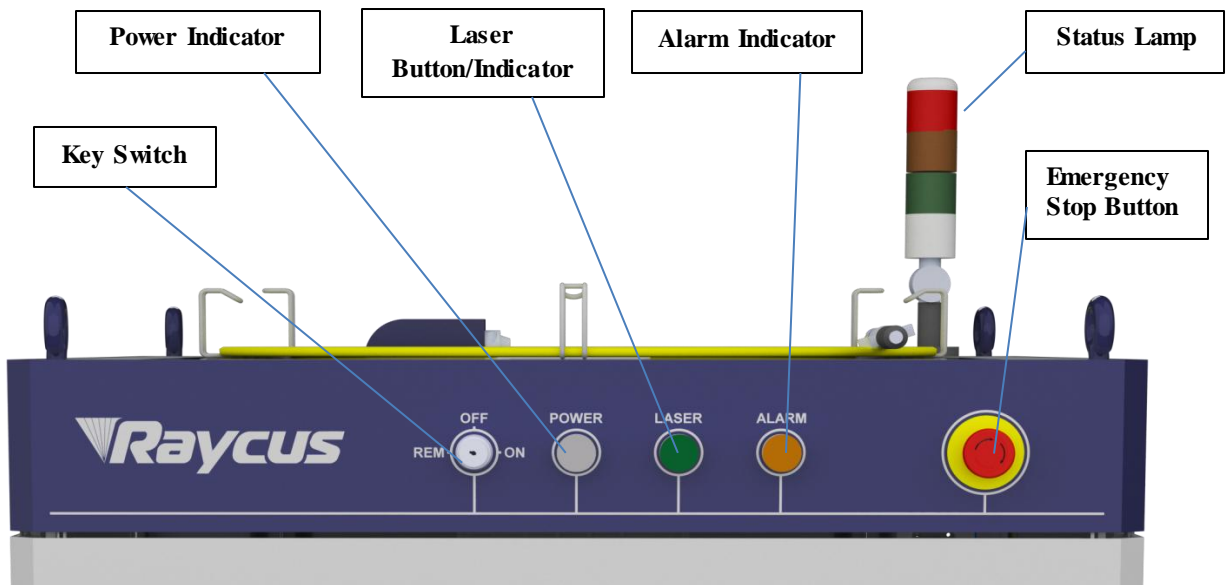

Figure 8 Front panel

REM/OFF/ON (Key Switch):

The main power switch of the product, to be operated with a key (enclosed as a standard accessory).

Insert the key and turn clockwise to the “ON” position, the main control part of laser source is powered on and the Power Indicator (White) lights on.

Or turn counterclockwise to “REM” position, and short-connect the Pin 8 and Pin 9 of XP1 Port to work in “REMOTE” mode. And Hardwire control mode is also accessed with key at “REM” position.

POWER Indicator (White):

When main control system is powered on, this indicator will illuminate white.

LASER Button/Indicator (Green):

When main control system is powered on (Power Indicator illuminates white) and all Interlock ports are connected properly, press this button to power on the main power module of laser source and this indicator will illuminate green.

ALARM Indicator:

INTERLOCK alarm indicator. This indicator will illuminate Yellow during the control board powering-on and self-check processes. When the self-check is done and all INTERLOCK ports are working properly this indicator will turn off. When the laser source is in work, any INTERLOCK malfunction will bring this indicator to illuminate again.

STOP Button:

Press down to turn the laser off immediately in emergent situations. Turn it clockwise to release the button (recover to the normal position). Then use the key to turn the laser back on after the emergency is lifted.

Status Lamp:

When the laser key switch hits “ON” or “REM”, the green light is on. The red indicator is on when the laser is emitting. When the fault occurs, the yellow indicator light is on, accompanied by a siren sound. (Note: some certain client-customized version of XZ series product may have different definitions for each colored indicator of the status lamp).

4.2 Rear Panel

Figure 9 shows the rear panel of the product:

AC Input:

The socket for mains in. Please use only the enclosed power cord provided by Raycus. The socket features a protective cover and a lock. Please use the protective cover and lock when not using the product.

INTERFACES:

Control interface panel, including HARDWIRING XP1, SAFETY XP2, RS232, ANALOG XP4, ETHERNET XP5 interfaces. This control panel provides all control input signals and feedback output signals, including: RS232 communication, network port communication, laser on/off control, laser remote control mode selection, analog control, modulation signal, Interlock interface, laser emission power feedback signal, etc., Refer to Table 5, Table 6, Table 7, Table 8 and Table 9 for control line definitions. This socket comes with a protective cover and the lock. When users are not using the product, users shall cover the power input socket with the protective cover and lock it with the lock.

WATER:

Pagoda type water tube connector. The inlet and outlet are used for inflow and outflow of cooling water. The rear views of other higher power models are shown below for reference.

As shown in Figure 9, the circuit breaker (air switch) on the rear panel of the laser is the total power switch of the laser.

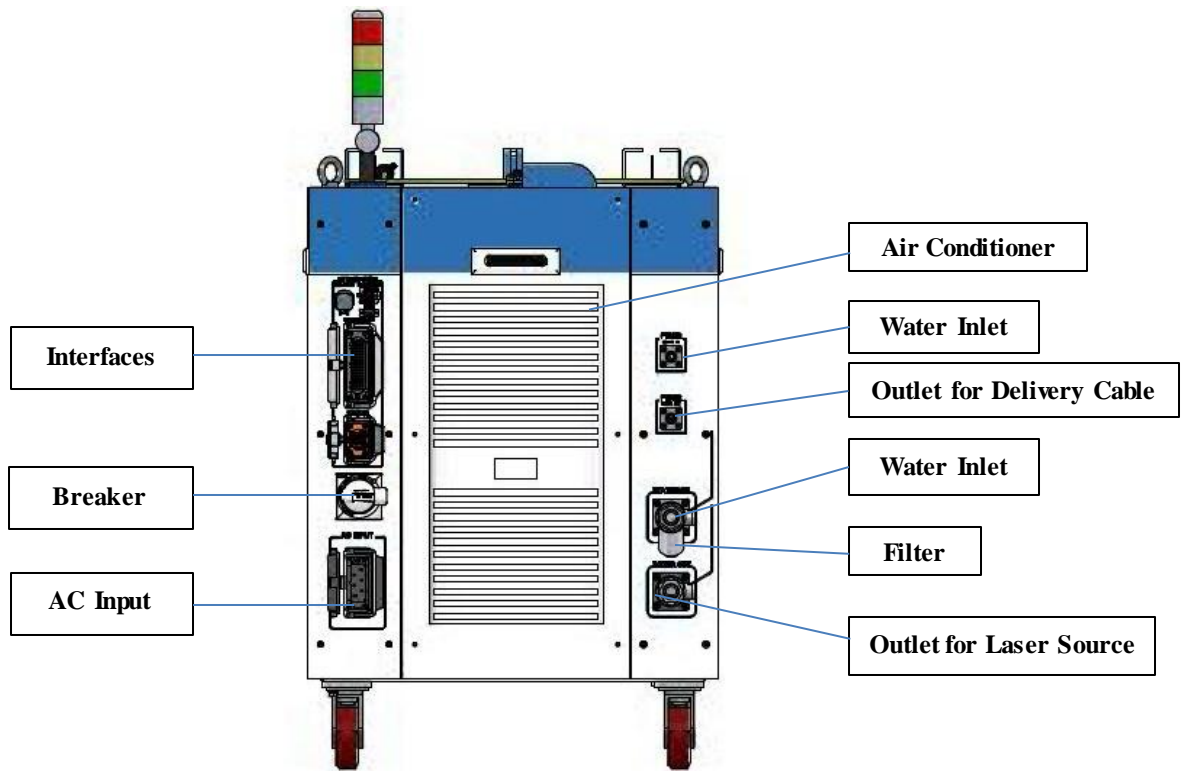
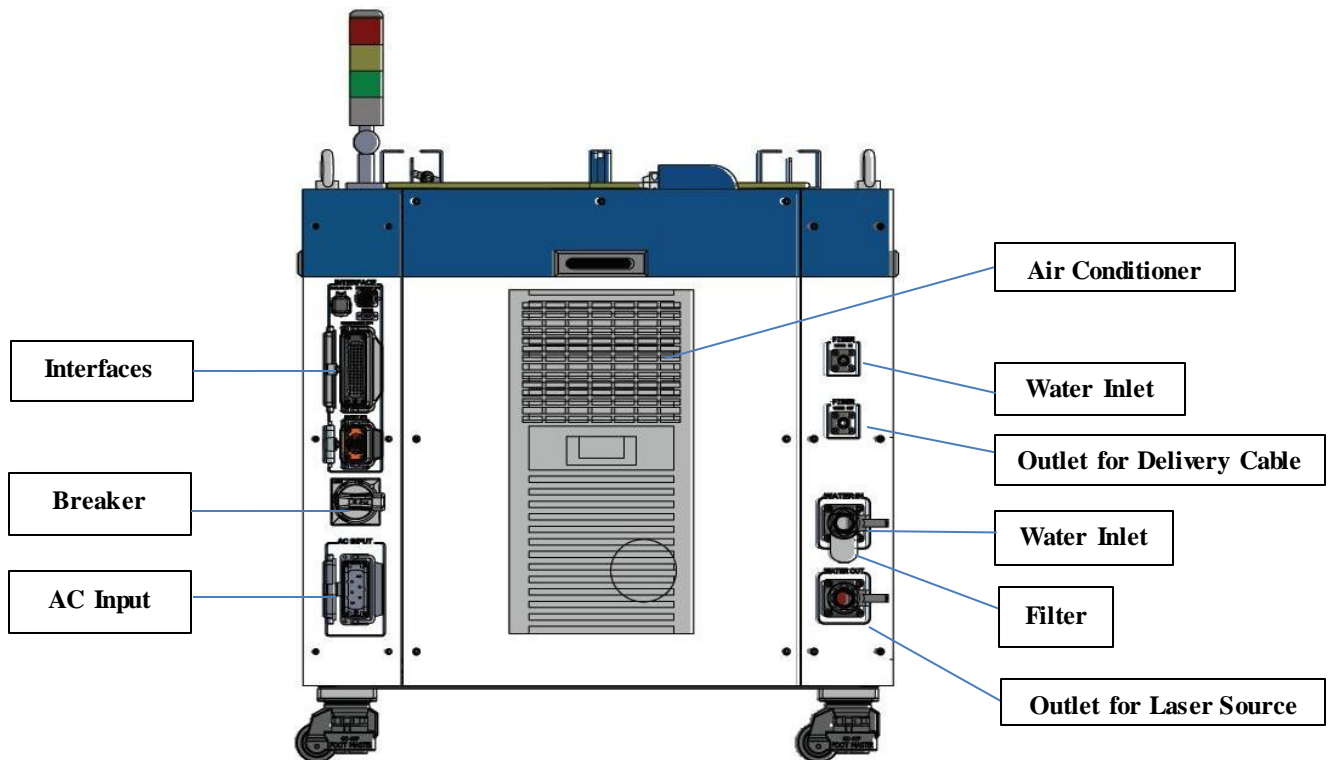

Figure 9.a - Rear panel (RFL-1500/1500,2000/2000)



Picture 9.b - Rear view of RFL-3000/3000,4000/2000,2000/4000,4000/4000

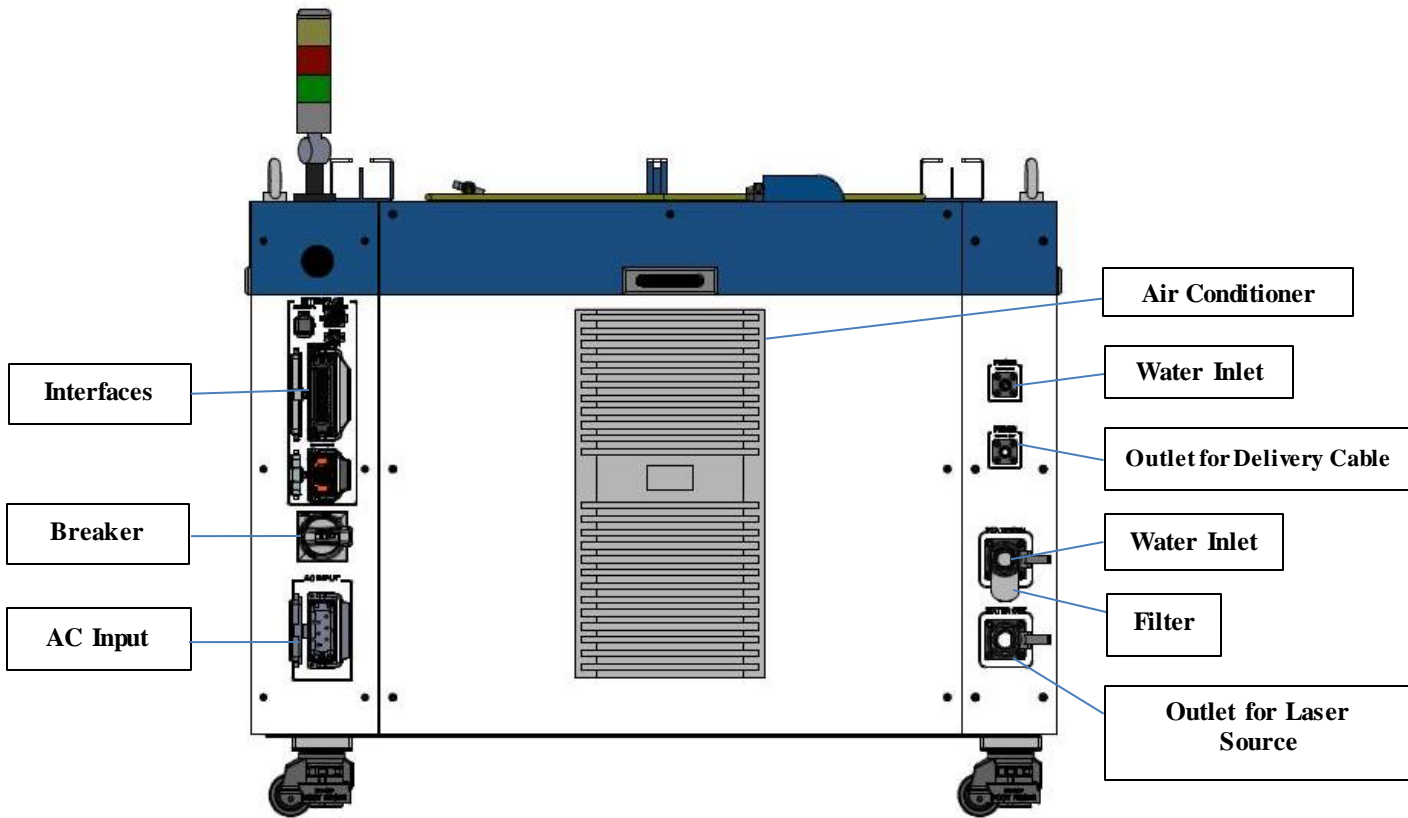

Figure 9.c - Rear view of RFL-6000/6000

Figure 9.-View of laser rear panel

4.3 Power Connection

	<p>CAUTION:</p> <p>a) Before connecting the product to AC power, users must check that the AC supply is applied in accordance with the specifications provided in Table 1.</p> <p>b) Incorrect connection of the power cable will damage the product. Please carefully check both the power cable and the control cable are correctly and firmly connected before usage.</p>
--	---

The power cord is provided by our company shown as Figure 10



a) 1500/1500,2000/2000 b) 3000/3000,2000/4000,4000/2000 c) 4000/4000,6000/6000

Figure 10 Power cords of different models

Insert the plug at the end of the power cord into the “AC INPUT” socket on the rear panel. Notice that the plug is wrong-side proofing. After insertion, lock it with the latch. As Figure 11 Power cord plug and socket.



a) 1500/1500,2000/2000 b) 3000/3000,4000/2000 c) 4000/4000,6000/6000

Figure 11 Power cord plug and socket

RFL-1500/1500-ABP and RFL-2000/2000-ABP models use four-core power cable. RFL-3000/3000,2000/4000,4000/2000,4000/4000,6000/6000 models use seven-core power cable. AC interface definition and requirements are shown in Table 4.

Table 4 Definition and parameter requirements of AC interface

RFL-1500/1500,2000/2000ABP PowerConnectorPin Definitions and Parameters				
Pin Number	Definition	ID	Diameter	Color
1	AC380V-L1	L1	6mm ²	Brown
3	AC380V-L2	L2	6mm ²	Black
5	AC380V-L3	L3	6mm ²	Grey
6	Protective Earth	PE	6mm ²	Yellow/Green
2, 4, 6, 8	/	None	/	/
RFL-3000/3000,2000/4000,4000/2000-ABPPowerConnectorPin Definitions and Parameters				
1, 2	AC380V-L1	L1	4mm ² /4mm ²	Brown
3, 4	AC380V-L2	L2	4mm ² /4mm ²	Black
5, 6	AC380V-L3	L3	4mm ² /4mm ²	Grey
7	Protective Earth	PE	4mm ²	Yellow/Green
8	/	/	/	/
RFL-4000/4000,6000/6000-ABPPowerConnectorPin Definitions and Parameters				
1, 2	AC380V-L1	L1	6mm ² /6mm ²	Yellow
3, 4	AC380V-L2	L2	6mm ² /6mm ²	Green
5, 6	AC380V-L3	L3	6mm ² /6mm ²	Red
7	Protective Earth	PE	6mm ²	Yellow/Green
8	/	None	/	/

Standard Power cord length is 8m for RFL-C3000XZ/C4000XZ models, and 15m for RFL-3000/3000, 2000/4000, 4000/2000, 4000/4000, 6000/6000-ABP models.

NOTE:

The appearance of the AC input connector used in RFL-3000/3000, 2000/4000, 4000/2000 ABP is the same as that used in RFL-4000/4000, 6000/6000-ABP models, only the pin (male pin, female core) and core module are changed, the pin is replaced with rated current of 40A, and the core module is replaced accordingly.

4.4 Control Interface Definition

The laser source comes with control signal connectors, but without control signal cables. The connectors are shown in Figure 12.

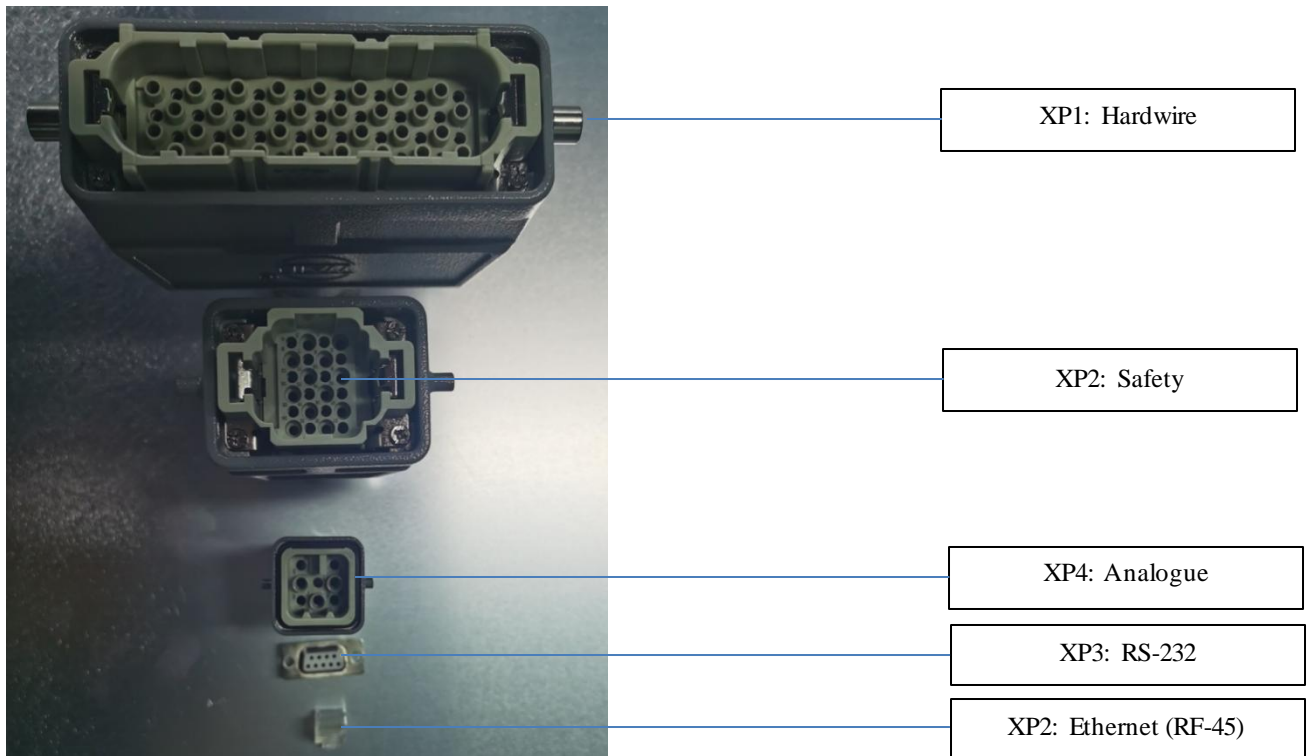

Figure 12 Control signal connectors

4.4.1 Safety XP2 24 PinInterface

The 24-pin hard wire interface, with remote control system power-on, remote main power power-on, and active and passive output of some lasers. Detailed interface definitions are shown below:

Table 5 Safety XP2 24 pin interface definition

No.	Type	Description
1	MOD+	Laser emission control, voltage input; Fiber Laser ON: 4~30 V; Fiber Laser OFF: -3~2 V; Maximum modulation frequency: 5 kHz.
2	MOD-	
3	OUT (FET S pole)	Laser emission indicator, MOSFET D pole, S pole output; electric current <1A, Vds <30V Passive Signal
4	OUT (FET D pole)	
5	OUT	Laser emission warning light negative, electric current <100mA
6	OUT	The main power supply is energized to the negative of the warning lamp, electric current <100 mA
7	OUT (24V)	The laser emission and the main power supply are energized to the positive pole of the warning light, electric current <400mA
8	IN	During REM mode, the remote main control board is powered on, 24V active contact input, and external voltage or grounding is not allowed; When pin 8 and 9 are closed, the main control board will be powered on.
9	IN	
10	24V OUT	The laser emission and the main power supply are energized to the positive pole of the warning light, electric current <400mA.
11	OUT	Front panel emergency stop output 1, relay contact output, passive contact , electric current <100mA, voltage <30V;
14	OUT	

		After pressing the current panel emergency stop, 11, 14 open circuit, otherwise for short circuit.
12	OUT	Front panel emergency stop output 2, relay contact output, passive contact, electric current < 100mA, voltage < 30V;
13	OUT	After pressing the current panel emergency stop, 12, 13 open circuit, otherwise for short circuit.
15	OUT (FET S pole)	The main power supply has been switched on for output indication, MOSFET D and S poles output; electric current < 0.5A, voltage < 60V.
16	OUT (FET D pole)	
17	IN	Interlock1 input, active contact, normal short connection 17, 20, no external voltage or grounding.
20	IN	
18	IN	Interlock2 input, active contact, normally short connection 18, 19, no external voltage or grounding.
19	IN	
21	IN	When the remote main power is powered on, it is same with the function of the Power button on the front panel. When Pins 21 and 22 are closed, the main power supply is started. The active outlet points can't not be externally voltage or grounded.
22	IN	
23	OUT	The laser has been energized and output;
24	OUT	OFF - the laser key switch is in the OFF position; Closed - the laser key switch is in the ON or REM position; Passive contact, external voltage signal, voltage less than 30V, electric current less than 1A.

a) Mode Signal

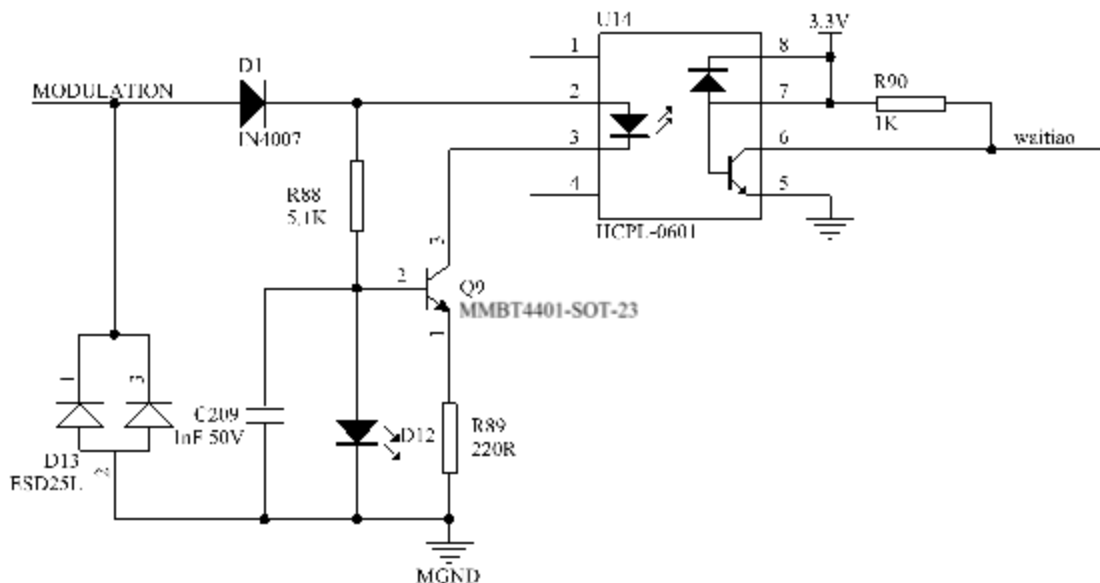

Figure 13 Mod signal schematic diagram

This signal is 5/24V compatible, and reverse connection is not allowed.

When the key switch is turned to “ON” and the laser works in the external laser control mode, the MOD is used to control the laser emission and turn off;

When the key switch is turned to “REM” and the laser is working in the external laser control mode, MOD and XP1-A2 (at this time the A2 position light enable signal) are united to control the emission and turn off of the laser (in REM mode, the laser can only be controlled by A2, need to be customized).

b) Passive Laser-Emitting Indication and Main Power-On Indication

XP2's 3/4 laser emission indication, 15/16 is the main power supply output indication, the internal circuit diagram is shown in Figure 13.

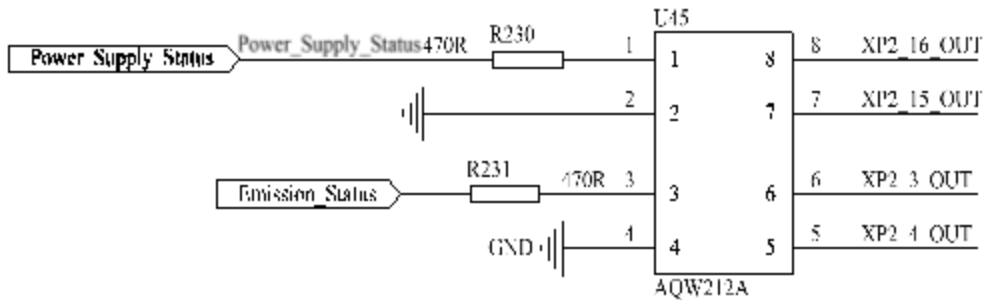

Figure 14 Internal schematic diagram

Recommended wiring diagram (12V has been taken as an example)

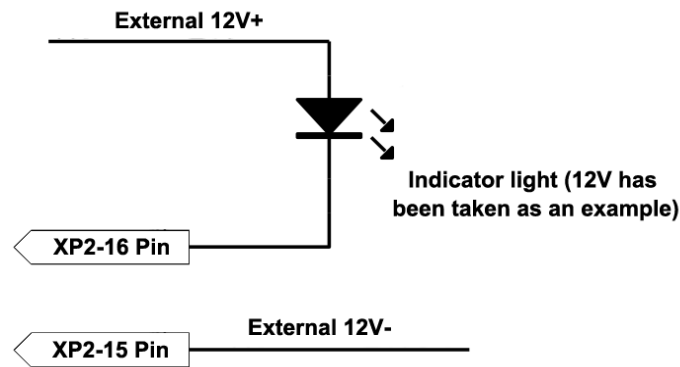

Figure 15 Recommended wiring diagram

c) Active Light Indicator and Main Power on Indicator

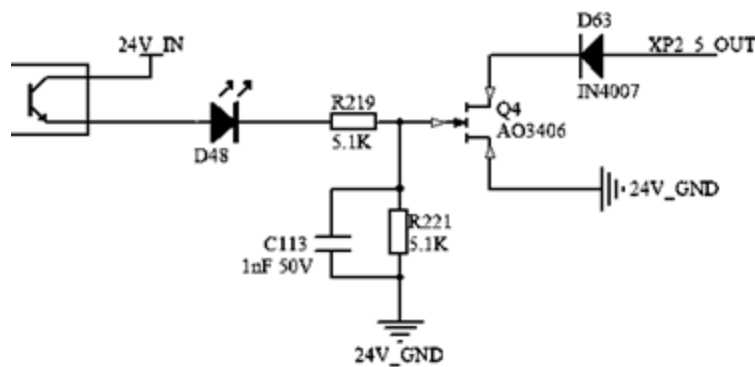

Figure 16 Internal circuit diagram

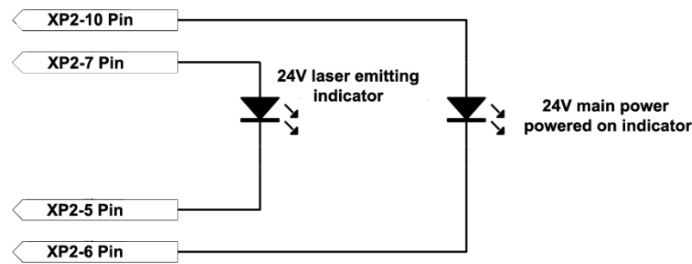

Figure 17 Recommend wiring diagram

d) Power On the Remote-Control Board

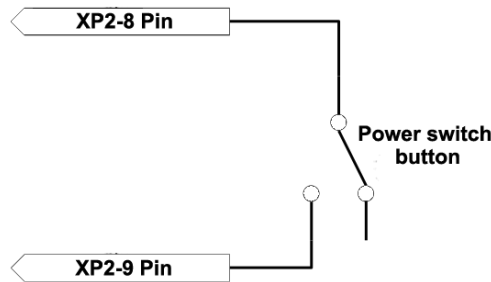

Figure 18 Recommended wiringdiagram

When the laser key switch on “REM”, it must be short-connected to the 8/9 pin main control board to power on.

e) Remote Main Power Supply

This signal is used to power on the main power supply through the XP2 interface.

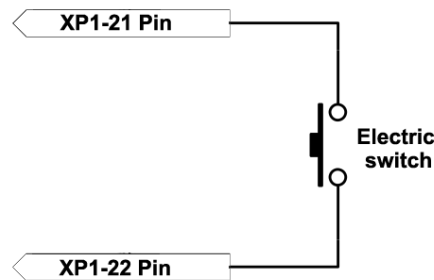

Figure 19 XP2 Remote mainpowersupplywiringdiagram

f) The Control Board is Poweredon And Output

This signal is a relay output, and the relay is closed after the main control board is powered on.

4.4.2 Hardwire XP1

64 pin hard wire interface, featuring the control signal input and output for the laser working in remote mode. The input high level is valid when it is greater than 18V, and the input low level is valid when it is lower than 3V. Detailed interface definitions are shown in Table 6 below:

Table 6 XP1 Hardwire interface definition

Pin		Type	Descriptions
Pin No.	Pin Name		
A1	Laser request	Input	Input signal and request laser, laser will receive other commands only after this bit is valid
A2	Programming mode execution	Input	Rising edge will initiate the laser source to emit laser power according to the pre-downloaded programming commands. Program number is determined by Pin A8~A14. 1) if the program number is 0000000 and Pin A6 is high, the laser power is set by AD analog value; 2) if the program number is 0000000 and Pin A6 is low, the laser power is set by Raycus Laser Control System (Raycus House-made Software); 3) if the program number is 0000000 and Pin A6 is low and A3 is high, the laser emission is controlled by Raycus Laser Control System (Raycus House-made Software)
A3	Internal model	Input	High level enables the Raycus Laser Control System
A4	Reset	Input	Effective high level and clear the laser alarm bit, the effective high-level time will last at least 1ms
A5	Guide laser	Input	Valid until guide laser on.
A6	Analog control	Input	Input signal, it is valid after be able to simulate the input signal (Program num = 0000000)
A7	Stop editing	Input	Stop editing immediately once in high level.
A8	Program number selects address	Input	Input signal, low level
A9~A14	Program number selects address 1-6	Input	Input signal, high bits 1 ~ 6s, select program number
A15	Synchronization	Input	Backup
A16	COM	The reference for all signals	/
C1	The laser drive power on	Input	Input signal, rising edge to turn on the main power, falling edge to turn off the main power.
C2	Null	/	/
C3~C6	Optical gate selection	Input	Input signal:C3is low level, C6 is high level; 0000 - Optical Gate closed 0001 - Optical Gate 1 is open 0010 - Optical Gate 2 is open 0011- Optical Gate 3 is open (Only working for laser source featuring Optical Gate function, and as standby for normal models.)
C7	Currently reserved (intended as an enabling signal in QCW mode)	Input	Input signal, enabling QCW mode (Only working for laser source featuring QCW mode)
C8~C16	/	/	Backup

B1	Laser ready	Output	Indicate that the laser is ready for emission.
B2	Laser emitting	Output	Indicate that the laser is emitting.
B3	Internal mode Indicator	Output	Indicate that the laser is working in Internal mode.
B4	Abnormal	Output	Indicate that the laser is in abnormal condition.
B5	Guide laser indicator	Output	Indicate that the laser guide laser is on.
B6	AD mode	Output	Indicate that the laser is working in AD mode.
B7	Laser receiving request signal	Output	Indicate that the laser receives Request Signal (Pin A1).
B8	Main power on	Output	Indicate the main power is on.
B9	Waveform mode Indicator	Output	Indicate that the laser is working in Waveform mode.
B10	Waveform mode execution finished	Output	Indicate that the Waveform mode is successfully done. Invalid pin A2 will reset this pin.
B11	Waveform mode abnormally finished	Output	Indicate that the Waveform mode is abnormally finished. Reset (Pin A4) will reset this pin.
B12	Synchronization signal output	Output	High level valid, low level invalid
B13	Alarm	Output	Indicate that the laser is having alarms.
B14	Backup	/	/
B15	External power source +	/	External power source of 24V. All output pins are effective when Pin B15 and B16 are connected with 24V external power source.
B16	External power source -	/	
D1~D4	Working optical gate indicator	Output	Indicating the current working Optical Gate: 0000- Optical Gate disabled 0001-Optical Gate 1 is working 0010-Optical Gate 2 is working 0011-Optical Gate 3 is working D1 low level, D4 high level (Only working for laser source featuring Optical Gate, and as standby for normal models)
D5	Cooler warning	Output	Warning for the current cooling water temperature.
D6	Cooler alarm	Output	Alarm for the current cooling water temperature.
D7	QCW mode	Output	Indicate the laser source is working in QCW mode (Only for model featuring QCW function)
D8~D11	Hardware address	Output	Coding-Cable function 0000- Laser source number 0 0001- Laser source number 1 D8 low level, D11 high level
D12~D16	Backup	/	/

4.4.3 XP3 RS232 Interface

The 9-pin serial interface is used for the communication between the laser and the Raycus Laser Control System. The definitions are shown in Table 7 as follows:

Table 7 XP3 serial interface definitions

Pin no.	Type	Description
2	IN	RXD, Serial port receiving pin of the laser
3	OUT	TXD, Serial port transmitting pin of the laser
5	COM	GND, Serial port common end

4.4.4 XP4 Analog Interface

The 8-Core Harting port analog interface, is used to control the emission power of the laser by analog in AD mode, and can also monitor the output laser and power feedback signals of the laser. The interface definition is shown in Table 8 below:

Table 8 XP4 analog interface definitions

Pin No.	Type	Description
1	IN	0~10 V analog signal, laser power control signal in AD mode ,0-10 V corresponding to 0-100% emission power
2	AGND	Analog Signal location
3	OUT	Power amplifier voltage output; 0 V: 0% laser power output, 8 V: 100% laser power output
4	Reference	Reference for power amplifier voltage
5	OUT	High reflection amplification voltage (reserve for standby, not have yet)
6	Reference	Reference for High reflection Voltage

4.4.5 XP5 Ethernet Interface

The interface definition is shown in Table 9 below:

Table 9 XP5 communication interface definition

Pin No.	Function	Description
1	TX+	Data transmission+
2	TX-	Data transmission-
3	RX+	Data acceptance+
4	N/C	No connection
5	N/C	No connection
6	RX-	Data acceptance-
7	N/C	No connection
8	N/C	No connection

4.5 Interlocking

Raycus ABP series models are designed with an interlocking function, which is a two-channel mechanism with output monitoring and manual/automatic reset.

When the safety interlocking circuit is open, the safety circuit will disconnect the power of the optical module and then stop the laser emission. To restart the main power supply, users must close both interlocking channels (24-Pin interface: Pin 17 and Pin 18 short-connected, Pin 19 and Pin 20 pins short-connected). Otherwise, the main power will be turned off and the laser cannot be turned on.

If the interlock is shorted/closed (the “Emergency Stop” button is also released) and there is no error alarm, press the “Start” (LASER) button to restart the main power supply, and the “main power has been started” pin of the external interface will have a high level.

When the safety interlocking circuit is open or the error is detected, the main power supply of the optical module will be turned off, and the “main power supply has been started” signal of the interface will become low level. The detected “error state” is latched and the on-board relay opens the manual reset loop with monitoring until the error is cleared, thus preventing the laser from being restarted.

If errors such as short circuit between interlocking channels or short circuit of start (LASER) button are detected, the safety interlocking loop cannot be reset before the error is cleared.

4.6 Schematic Diagram of the Laser Electrical Circuit

The schematic diagram of the laser is as Figure 20:

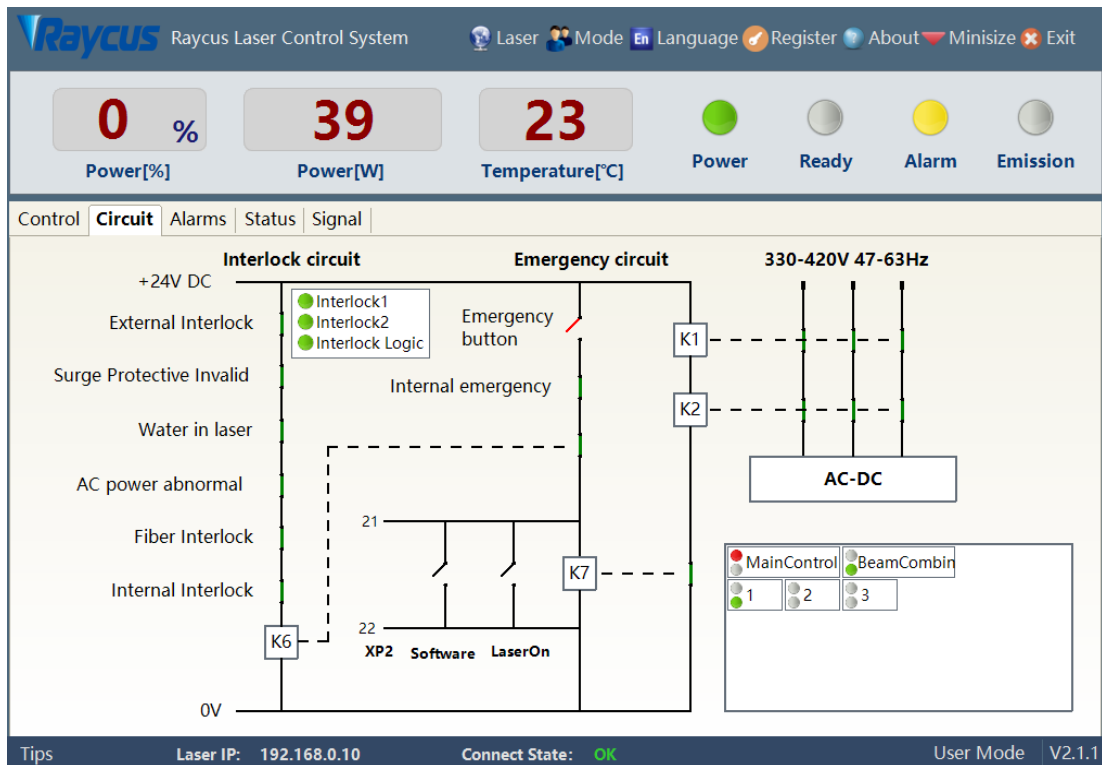

Figure 20 Schematic diagram of the laser electrical circuit

4.7 Operation Start-ups Sequences

- a) Turn on the water cooler, check whether the water pipe is leaking. Turn off the water cooler and connect electrically.
- b) Make sure the circuit breaker is in “OFF” position and the “Emergence Stop” button of the front panel is pressed down. All electrical connections must be completed before the laser is powered on;
- c) Confirm that the three-phase electrical connection is correct and the power supply meets the specifications, turn on the water cooler.
- d) Close the rear panel circuit breaker, release the laser front panel emergency stop switch; ensure that all laser doors are closed, optical cable fiber delivery connector has been inserted into the laser processing head (or corresponding equipment), all interlock interfaces have been closed;
- e) Select the required control mode according to 1.4 “control mode”, turn on the key switch, start the main power supply waiting for the laser to be “Ready” state. When the laser is ready, the tricolor status lamp on the top the laser lights green, representing that the laser is ready for emitting the laser beam.

NOTE:

- a) Raycus high power continuous wave lasers are equipped with relative individual backpack air conditioner, turn on the switch, the air conditioning will then begin to work.
- b) When the working environment temperature and relative humidity of the laser are in the dew point area (Blue), please let the air conditioner work for 30 minutes before operating the laser.

5 Control Mode Selection

Raycus quasi continuous lasers provide two control modes, ON Mode and REM Mode, respectively. Users can choose their needed mode by turning the key on the front panel to the corresponding position. The specific operation is as Table 10.

Table 10 Control modes and their subsequent operating methods

	AD mode	Output remote control	Programming mode	Power	Laser emission and shutdown	Red guide beam
ON Mode	Close ①	Close ②	-	Communication ⑬	Communication ⑪	Communication ⑫
	Enable ③	Close ②	-	XP4-1/2 Foot voltage	Communication ⑪	Communication ⑫
	Close ①	Enable ④	-	Communication ⑬	XP2-1/2Foot level status	Communication ⑫
	Enable ③	Enable ④	-	XP4-1/2Foot voltage	XP2-1/2Foot level status	Communication ⑫
REM Mode	Close ⑤	Close ⑥	Close ⑦	Communication ⑬	Communication ⑪	Communication ⑫
	Enable ⑧	Close ⑥	Close ⑦	XP4-1/2Foot voltage	Communication ⑪	XP1-A1/A5 high
	Close ⑤	Enable ⑨	Close ⑦	Communication ⑬	XP1-A1 Laser request high XP1-A2 Laser emission energy XP2-1/2 input MOD signal	XP1-A1/A5 high
	Enable ⑧	Enable ⑨	Close ⑦	XP4-1/2Foot voltage	XP1-A1 Laser request high XP1-A2 Laser emission energy XP2-1, 2 input MOD signal	XP1-A1/A5 high
	Close ⑤	Enable ⑨	Enable ⑩	By programming instruction	XP1-A1 Laser request high XP1-A2 Upward initiation of implementation procedures	XP1-A1/A5 high

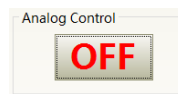

① Send “DEC” through communication, or click the  button on the host computer software;

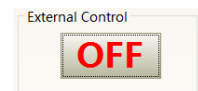

② The communication sends “DLE”, or the host computer software clicks the  button ;

③ The communication sends “EEC”, or the host computer software clicks the



button;

④ The communication sends “ELE”, or the host computer software clicks the

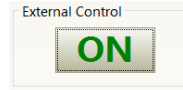

button;

⑤ XP1-A1 is high level, XP1-A6 is low level or floating;

⑥ XP1-A1 is high level, XP1-A3 is high level;

⑦ XP1-A1 is high level, XP1-A8~A14 are low level or floating;

⑧ XP1-A1 is high level, XP1-A6 is high level

⑨ XP1-A1 is high level, XP1-A3 is low level or floating

⑩ XP1-A1 is high level, not all XP1-A8~A14 are low level;

⑪ Communication send “EMON” or the host computer software click the



“ON” button to emitting the laser;

The communication sends "EMOFF" or the host computer software clicks the



“OFF” button to turn off the laser;

⑫ The communication sends “ABN” or the host computer software clicks the

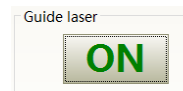

button to

output guide laser;

Communication send “ABF” or the host computer software click the



button to turn

off the guide laser;

⑬ Communication sends “SDC XX” to set the power percentage, XX represents the power percentage,

or the host computer software clicks the

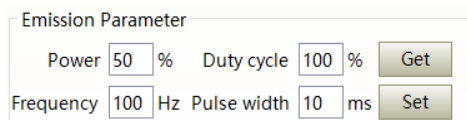

button;

5.1 ON Mode

In“ON” mode, users can set different operating modes by using the Raycus Laser Control System (RLCS) or using a direct communication command method, which can be memorized by the laser source even after powering off.

5.1.1 AD Mode Enable

When the AD mode is enabled, the power of the laser is determined by the analog voltage of 1 or 2 feet of the XP4; if the AD mode is not enabled, the power of the laser can be set by the Raycus Laser Control System or by sending the “SDC XX” command.

5.1.2 Emission External Control Enable

When the emission external control is enabled, the laser emission is determined by the level difference between the pins of MOD+, MOD- in the XP2 port; if the emission external control is not enabled, the laser emission and shutdown are determined by the output button in the Raycus Laser Control System, or send “EMON” command to turn laser emission on, and send “EMOFF” command to turn laser emission off.

5.1.3 Guide laser (Red Guide Beam) Control

In “ON” mode guide laser can only be turned on/off by using Raycus Laser Control System, or by sending command of “ABN” (on)/ “ABF” (off).

When the guide laser is turned on, the laser will turn off the “Ready” signal, and the green indicator of “Status Lamp” will turn off. When the guide laser is turned off, the laser “Ready” signal will resume immediately, and the green indicator of “Status Lamp” will be lit on.

5.1.4 Programming Mode

In “ON” mode, when the current program number of the laser is not 0, the laser runs in the “Programming” mode.

Please use the Raycus Host Computer Software to edit the waveform and select the pre-run program number.



When the laser is in the internal control mode, press the “ON” button, or send the “EMON” command, the laser will start to run the program, send “EMOFF” or press the



“OFF” button can terminate the laser emission at any time;

When the laser is in “External Control” mode, the rising edge of MOD starts the program to start execution, and the falling edge of MOD can terminate the program at any time

5.2 REM Mode

5.2.1 AD Mode

When the Pin A1 and Pin A6 of the XP1 port are both set high, the laser runs into the “AD” mode, and the current laser emission power is determined by the analog voltage of Pin 1 and Pin 2 of the XP4 port.

When the Pin A6 of the XP1 port is set low or suspended, the laser emission power is set by the Raycus Laser Control System or by sending command (“SDCXX”) directly.

5.2.2 External Control

When XP1's A1 and A3 are both set high, the laser is in the Internal Control mode, the laser is controlled by the Host Computer Software on button or the communication sends “EMON” to control the laser emission, “EMOFF” controls the laser emission off; when XP1's A1 is high, A3 is suspended or set low, the laser is in external control mode, and the laser emission is determined by the high and low levels of XP1's A2 and XP2-1, 2 pin MOD signal together.

5.2.3 Guide laser Control

When both A1 and A3 of XP1 are set high, the laser is in the guide laser internal control mode, and the guide laser is controlled by the guide laser button of the Host Computer Software or the communication sending “ABN” and “ABF”; when A1 of XP1 is set high, A3 is suspended or set low, the laser is in external control mode, and the guide laser is controlled by A5 of XP1.

The guide laser component of the product works by means of communication, so there is a time delay of at least 10ms when the guide laser is turned on and off;

When the guide laser is turned on, the laser cannot be set to “Ready”. Only when the guide laser is turned off, the laser beam with a wavelength about 1080nm is then allowed to set to the “Ready” condition (if this limit needs to be changed, please contact Raycus regarding the users’ specific need).

5.2.4 Programming Mode

When XP1's A1 is set high and A8-A14 is not 0, the laser is in “Programming” mode. At this time, the laser emission is controlled by XP1's A2, and the laser emission waveform is determined by the edited waveform.

6 Laser Wiring Mode and Operation Steps

6.1 Internal Control in ON Mode

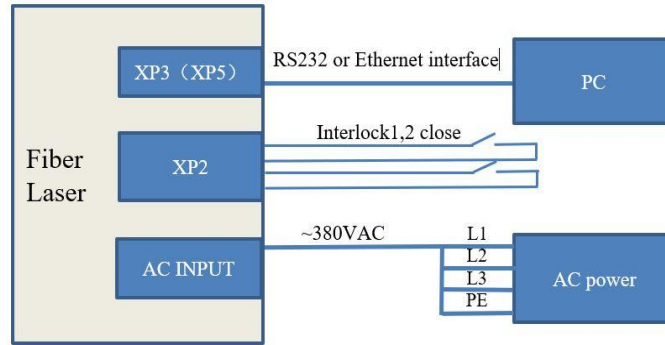

Figure 21 Key switch at “ON” position software mode wiring diagram

Operation method:

- a) Turn the knob switch on the rear panel to “ON”;
- b) Turn the key switch to “ON”;
- c) Open the Raycus Laser Control System;
- d) Click the guide laser “ON” button to view the guide laser;
- e) Turn off “AD” mode and turn off external control mode; (this mode can be memorized when power off)
- f) Click the main power “ON”;
- g) Waiting for “Ready”;
- h) Set laser emission parameters;
- i) Click the laser “ON”.

6.2 Laser Operating in External Control Mode

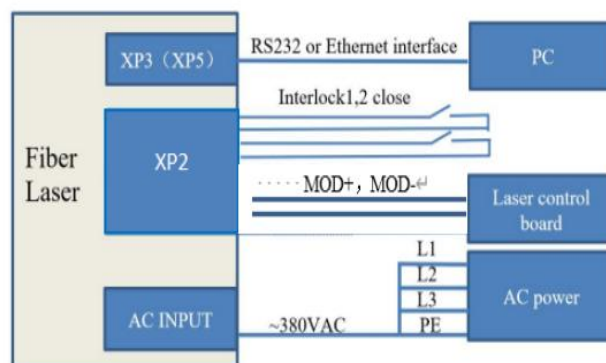

Figure 22 Wiring diagram of power internal and external control of laser emission by MODE

Operation method:

- a) Turn the knob switch on the rear panel to “ON”;
- b) Turn the key switch to “ON”;
- c) Open the Raycus Laser Control System;
- d) Click the guide laser “ON” button to view the guide laser;
- e) Turn off “AD” mode and turn on “External Control” mode; (this mode can be memorized after power off)
- f) Click the main power “ON”;
- g) Waiting for “Ready”;
- h) Set the percentage of laser emission power;
- i) MOD signal output high level to turn on the laser.

6.3 In ON Mode, the Laser Emission Power is Externally Controlled by Analog Signal

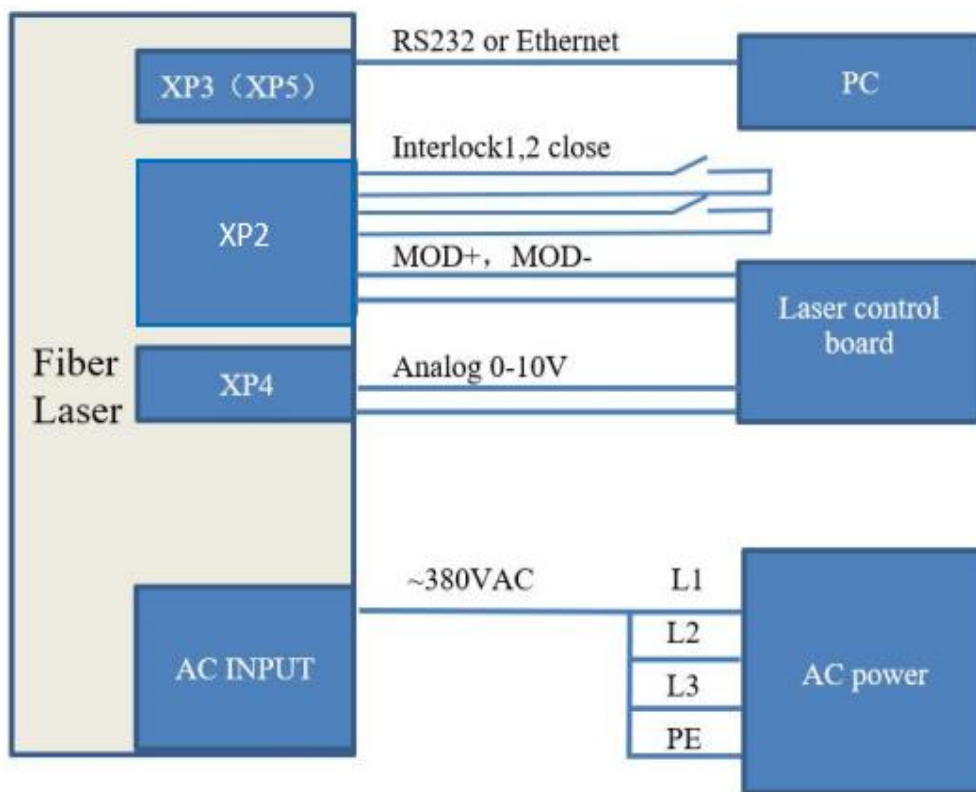

Figure 23 In ON mode, the power and laser emission controlled by analog wiring diagram

Operation method:

- a) Turn the knob switch on the rear panel to “ON”;
- b) Turn the key switch to “ON”;
- c) Open the Raycus Laser Control System;

- d) Click the guide laser “ON” button to view the guide laser;
- e) Turn on the “AD” mode and turn on the external control mode; (this mode can be memorized after power off)
- f) Click the main power “ON”;
- g) Waiting for “Ready”;
- h) The control board card outputs analog quantity and light signal.

6.4 Laser Operating in Programming Mode

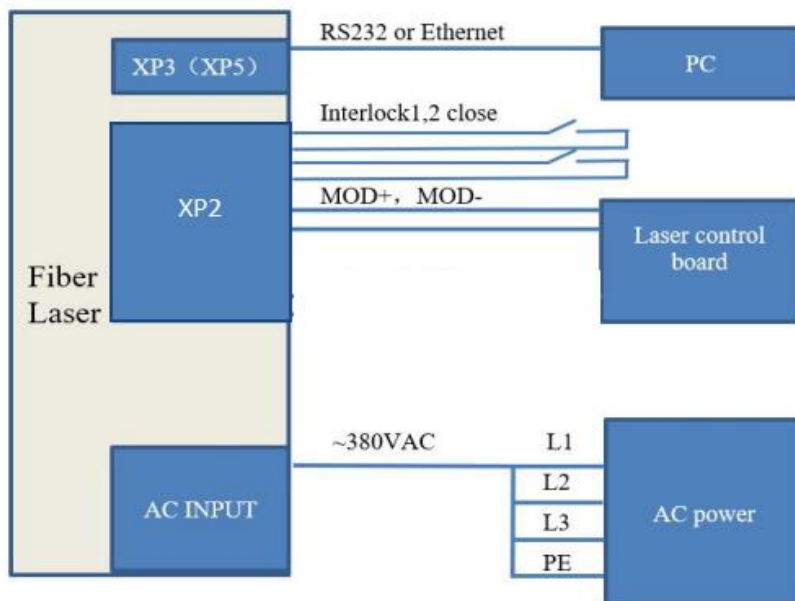

Figure 24 Wiring diagram of external control laser emission in programming mode, in ON mode

Operation method:

- a) Turn the knob switch on the rear panel to “ON”;
- b) Turn the key switch to “ON”;
- c) Open the Raycus Laser Control System;
- d) Click the guide laser “ON” button to view the guide laser;
- e) Click the main power “ON”;
- f) Waiting for “Ready”;
- g) Set the pre-executed waveform number (the program number is greater than 0);
- h) Start waveform at the rising edge of MOD signal.

NOTE:

The high-level time of MOD must be greater than the program running time. If MOD gives a falling edge in advance, the Raycus Laser Control System will display that the laser program is abnormally terminated.

6.5 Set the Power Analog Quantity in REM Mode to Control the Laser Emission

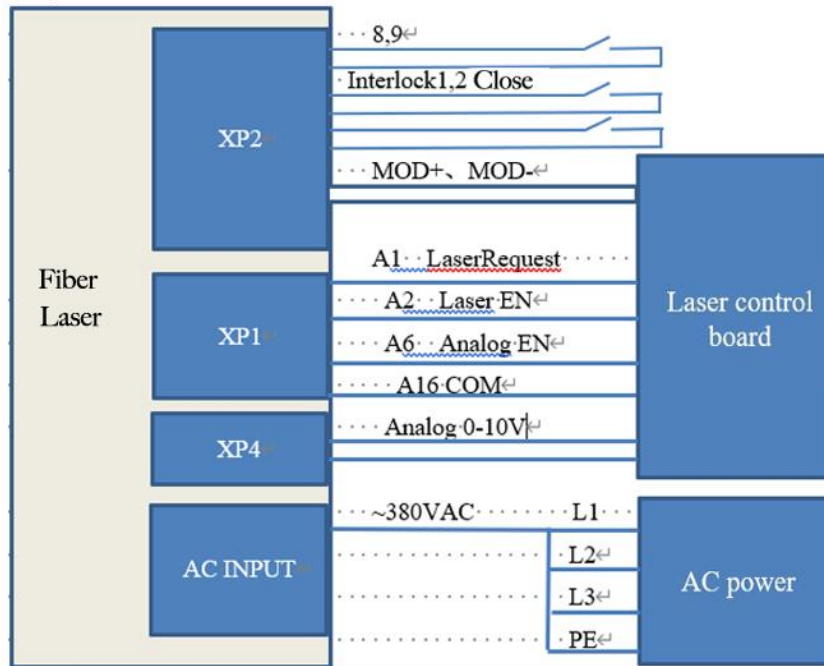

Figure 25 REM mode power and laser emission are externally controlled wiring diagram

Operation method:

- Turn the knob switch on the rear panel to “ON”;
- Turn the key switch to “REM”;
- Short-circuit pin 8/9 on XP2;
- XP1-A1 connects to 24V, XP1-A6 connects to 24V;
- Connect XP1-A5 to 24V and turn on the guide laser; after checking the optics, connect XP1-A5 to 0V and turn off the guide laser;
- XP1-C1 is connected to 24V, and the main power is turned on (users can also directly press the LASER button, or the host computer software clicks the main power “ON”);
- Waiting for “Ready”;
- XP1-A2 connects to 24V, and the control board outputs analog and MOD signals.

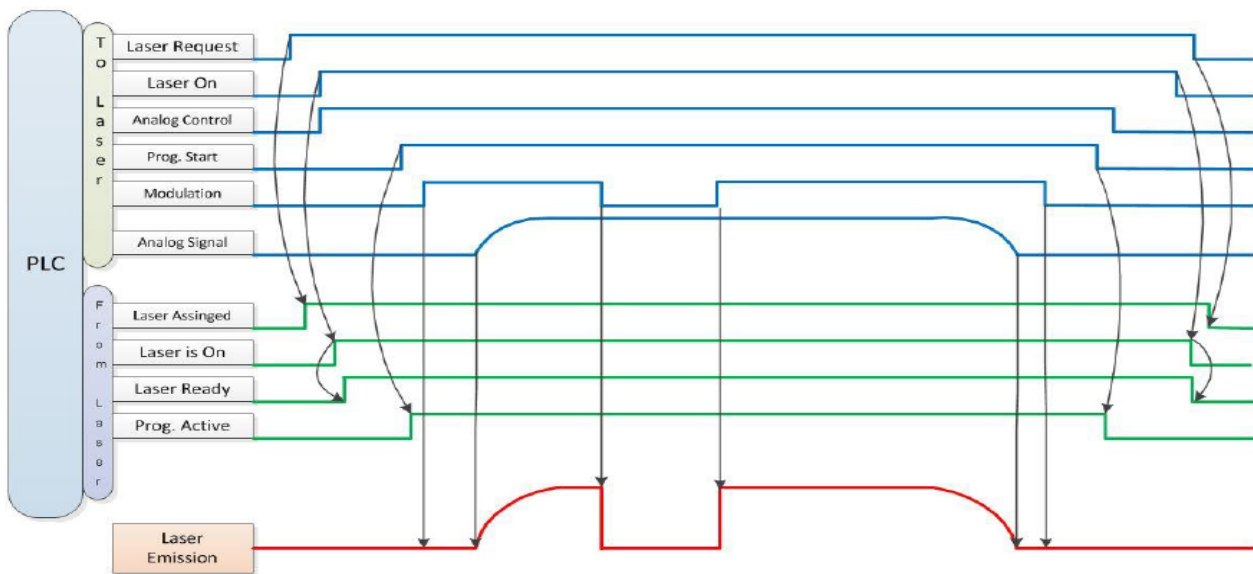

Figure 26 Timing diagram

6.6 Power Communication Setting in REM Mode

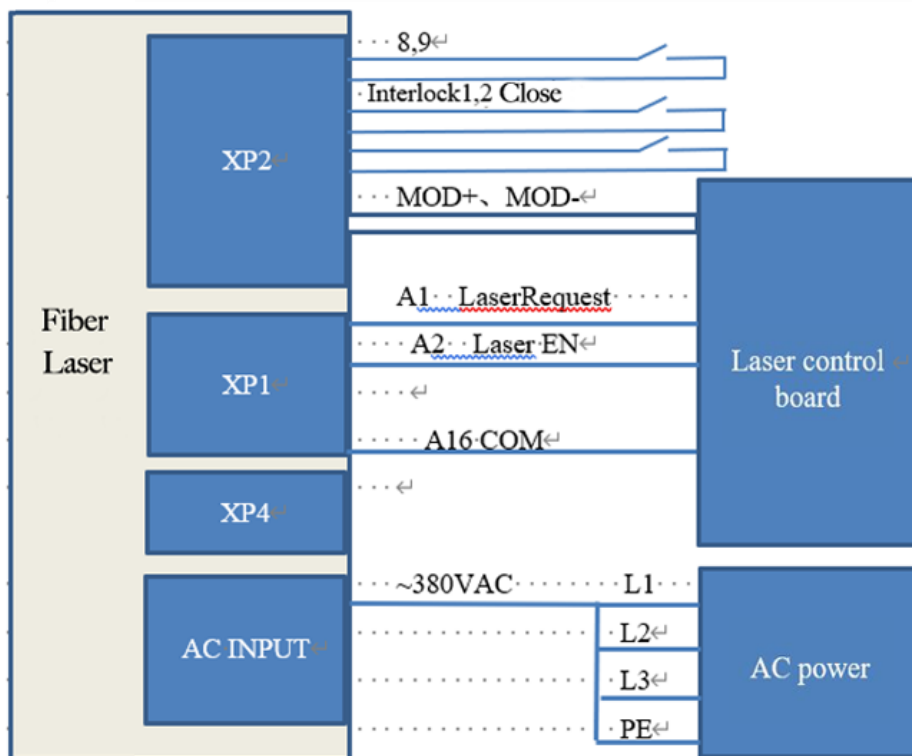

Figure 27 Wiring diagram of power internal control and laser emission external

Operation method:

- a) Turn the knob switch on the rear panel to “ON”;

- b) XP1-A1 connects to 24V;
- c) Connect XP1-A5 to 24V and turn on the guide laser; after checking the optics, connect XP1-A5 to 0V and turn off the guide laser;
- d) XP1-C1 is connected to 24V, and the main power is turned on (users can also directly press the “LASER” button, or the Host Computer Software clicks the main power “ON”);
- e) Waiting for “Ready”;
- f) The Raycus Laser Control System sets the power, XP1-A2 is connected to 24V, and the MOD signal of the control board card.

6.7 Programming Mode in REM Mode

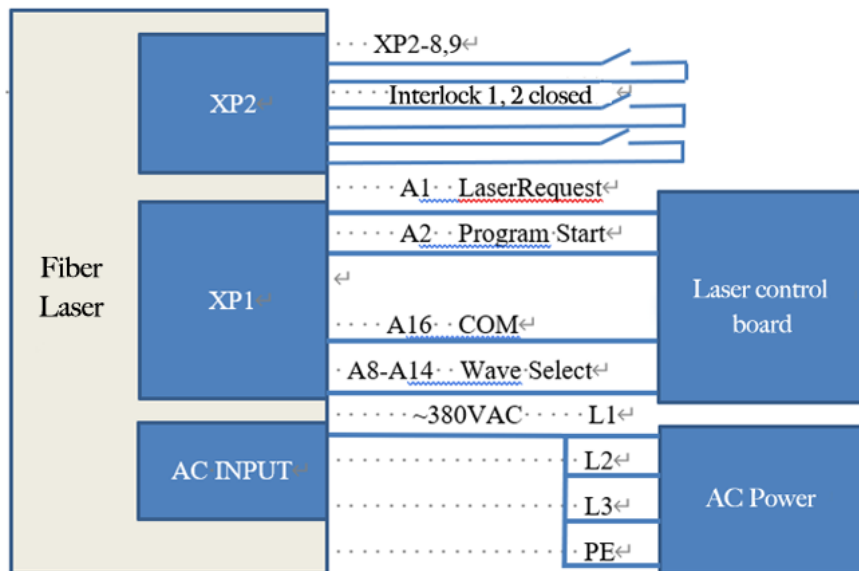

Figure 28 Wiring diagram of programming mode in REM Mode

Operation method:

- a) Turn the knob switch on the rear panel to “ON”;
- b) Turn the key switch to “REM”;
- c) Short-circuit pin 8/9 on XP2;
- d) XP1-A1 connects to 24V;
- e) Connect XP1-A5 to 24V and turn on the guide laser; after checking the optics, connect XP1-A5 to 0V and turn off the guide laser;
- f) XP1-C1 is connected to 24V, and the main power is turned on (users can also directly press the “LASER” button, or the host computer software clicks the main power “ON”);

- g) Waiting for ‘Ready’;
- h) XP1-(A8-14) select the number of the pre-executed program, set XP1-A2 high to start executing the program.

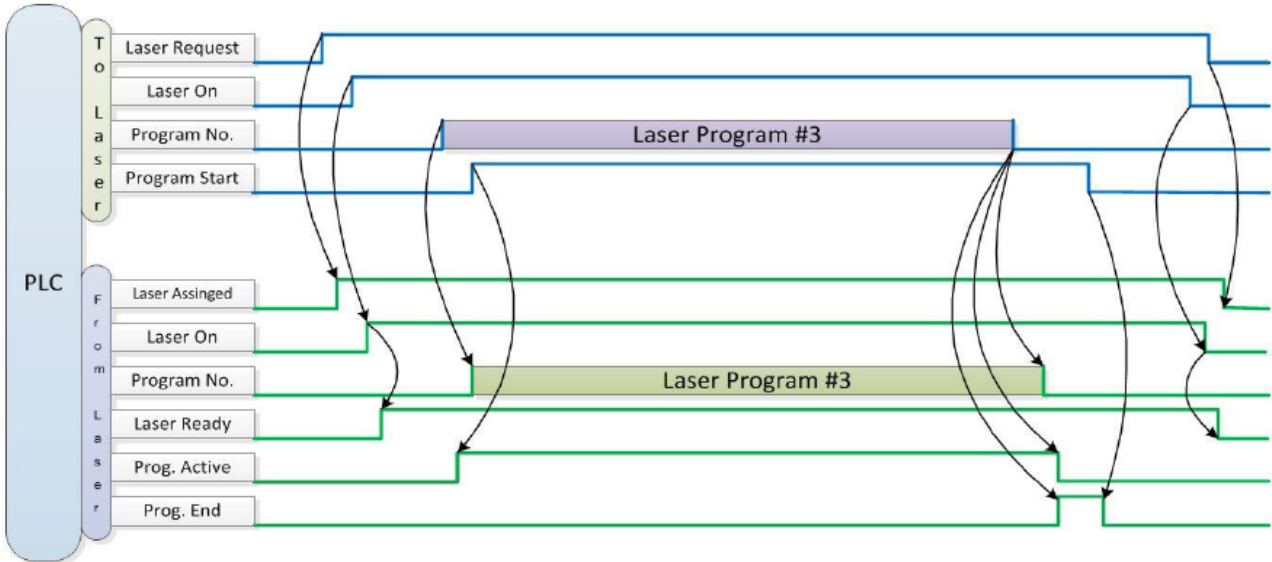

Figure 29 Timing diagram

7 RS232 and INTERNET Communication Commands

7.1 Port Configuration

- a) RS-232 configurations:
- b) baud rate:9600, data bit:8, stop bit:1, no parity bit and no control flow.
- c) Ethernet port configurations.
- d) Default laser IP address:192.168.0.10
- e) Laser port number:10001

7.2 Laser Communication Protocol (Ethernet Port & Serial Port)

All commands and return values in this protocol are composed of ASCII characters. Note the following points when generating commands:

- a) Commands generally consist of three or four letters, sometimes with additional values.
- b) All commands and return values end with the enter character (CR,0x0D, \r). If the laser receives a string with an “enter” character but the command is invalid, the “Command Err! \r” is returned.
- c) For easy identification, all commands are in capital letters. But actually, the commands are not case-sensitive. To facilitate identification, a space is inserted between the command and the parameter.
- d) Laser sends a return value for each command received. The return value generally contains the command content itself. If the returned content contains a numeric value or an error type, then the returned command content is separated from the numeric value or the error type with a colon (“:”).

The specific protocol and command examples are shown in Table 11:

Table 11 Laser protocol contents and command examples

Command	Description	Command Example
ABF	Aiming Beam OFF –Turn off red	Send: “ABF\r” Return: “ABF\r”
ABN	Aiming Beam ON – Turn on red	Send: “ABN\r” Return: “ABN\r”
DEABC	Disable External Aiming Beam Control	Send: “DEABC\r” Return: “DEABC\r”
EEABC	Enable External Aiming Beam Control	Send: “EEABC\r” Return: “EEABC\r”
DEC	Disable External Control	Send: “DEC\r” Return: “DEC\r”

EEC	Enable External Control	Send: "EEC\r" Return: "EEC\r"
DLE	Disable Hardware Emission Control	Send: "DLE\r" Return: "DLE\r"
ELE	Enable Hardware Emission Control	Send: "ELE\r" Return: "ELE\r"
EMOFF	Stop Emission	Send: "EMOFF\r" Return: "EMOFF\r"
EMON	Start Emission	Send: "EMON\r" Return: "EMON\r"
MPWROFF	Main Power OFF	Send: "MPWROFF\r" Return: "MPWROFF\r"
MPWRON	Main Power ON	Send: "MPWRON\r" Return: "MPWRON\r"
SPW	Set Pulse Width	Send: "SPW 100\r" Return: "SPW:100\r" (Set pulse width as 100ms) Other return values: "ERR: input Err\r" (Input pulse width <0.0001) "ERR: Out of Range\r" (Over maximum pulse width) "ERR: Duty Cycle too High\r" "ERR: Duty Cycle too Low\r" "SPW:100, Duty=100%\r"
SPRR	Set Pulse Repetition Rate	Send: "SPRR 1000\r" Return: "SPRR: 1000\r" "ERR: input Err\r" "ERR: Out of Range\r" "ERR: Duty Cycle too High\r" "ERR: Duty Cycle too Low\r" "SPW: 100, Duty=100%\r"
SDC	Set Diode Current (%) The set value must be less than 100% and above the minimum current setting value, which can be set to 0. If the set value is greater than 100, the default is input 100.	Send: "SDC 100\r" Return: "SDC: 100\r" Other return values: "ERR: Input Err\r" "Laser is worked in AD Mode\r"
RCS	Read Current Setpoint	Send: "RCS\r" Return: "RCS: 56.7\r" (The current set value is 56.7 %)
RPRR	Read Pulse Repetition Rate (Hz)	Send: "RPRR\r" Return: "RPRR:10\r" (Repeat frequency is 10Hz)

RBT	Read Board Temperature	Send: "RBT\r" Return: "RBT:36.6\r"
RPW	Read Pulse Width (ms)	Send: "RPW\r" Return: "RPW:5.5\r" (pulse width is 5.5ms)
RCT	Read Laser Temperature	Send: "RCT\r" Return: "RCT:34.5\r"
PERR	Reset Errors	Send: "PERR\r" Return: "PERR\r"
SUT	Set Up Time (ms)	Send: "SUT 50\r" Return: "SUT:50\r"
SDT	Set Down Time (ms)	Send: "SDT 50\r" Return: "SDT:50\r"
RUT	Read Up Time (ms)	Send: "RUT \r" Return: "RUT:50\r"
RDT	Read Down Time (ms)	Send: "RDT \r" Return: "RDT:50\r"
PSRT	Program Start	Send: "PSRT 1\r" Return: "PSRT:1\r"
PSTP	Program Stop	Send: "PSTP\r" Return: "PSTP\r"
ECM	Enable Calibration Mode – Power linear correction mode (in this mode, the external analog is corrected and output after filtering, so the response time of AD analog is larger than that of through mode)	Send: "ECM \r" Return: "ECM\r"
DCM	Disable Calibration Mode (AD analog response time is less than 100 us in this mode)	Send: "DCM\r" Return: "DCM\r"
Others	Command error	Send: "BGM\r" Return: "Command Err!\r"
STA	Read device status – Read the product status. A return value of 32-Bit digital information. The meaning of each Bit is as follows (undefined or "reserved" Bit negligible):	
	Bit 0	Normal operation
		Authorization time
	Bit 1	Normal
		Temperature too high
Bit 2	Emission Off	
	Emission On or in preparation	
		Send: "STA" Return: "STA:4100" returned value 4100(Decimal) can be converted to 0x1004 (hexadecimal), and then converted to binary to see that Bits2 and 12 have been set. The laser enable is on and the modulation mode is enabled

	Bit 3	No high reflection
		High reflection Abnormal
	Bit 4	External AD mode=off
		External AD mode=on
	Bit 5	Power Correction Mode=off
		Power Correction Mode=on
	Bit 6	Normal
		Sub-controlling communication abnormal
	Bit 7	Normal
		Sub-module abnormal
	Bit 8	Guidelaser=off
		Guidelaser=on
	Bit 9	The laser is not ready
		The laser is ready
	Bit 10	QCW mode=off
		QCW mode=on
	Bit 11	Module Main Power=off
		Module Main Power=on
	Bit 12	Modulation mode=off
		Modulation mode=on
	Bit 13	Normal
		Leakage sensors 1 leaking
Bit 14	Normal	
	Leakage sensors 2 leaking	
Bit 15	No laser	
	Laser is power on	
Bit 16	Gate mode=off	
	Gate mode=on	
Bit 17	AC input normal	
	AC input abnormal	
Bit 18	External Emission control=off	
	External Emission control=on	
Bit 19	Normal	
	Laser fault	
Bit 20	Slow up slow down mode off	
	Slow up slow down mode on	
Bit 21	A laser operates in ON" mode	
	A laser operates in REM" mode	
Bit 22	Wave mode off	

		Wave mode on	
Bit 23		Surge protector normal	
		Surge protector failure	
Bit 24		Normal	
		Low temperature fault	
Bit 25		Normal	
		Humidity alarm	
Bit 26		Normal	
		Water flowmeter 1 Flow Alarm	
Bit 27		Guide laser internal control	
		Guide laser External Control	
Bit 28		Normal	
		Water flowmeter 2 Flow Alarm	
Bit 29		Normal	
		Module locked	
Bit 30		Optical circuit safety interlock normal	
		Optical circuit safety interlock abnormal	
Bit 31		Normal	
		High average power	

8 Raycus Laser Control System Instructions

Software download link: <http://www.raycuslaser.com/list/56.html>

8.1 Main Interface of the Software

The software main interface is shown as Figure 30:



Figure 30 Raycus Laser Control Software displays main interface

8.2 Multi-laser Control

Click “Select Laser” on the main interface, and the laser selection list will be popped up. Each laser has a different IP address. Select the corresponding IP address to select the corresponding laser. After selecting the laser to be operated, click “Close” to close the laser selection interface. Multi-laser control is as Figure 31:

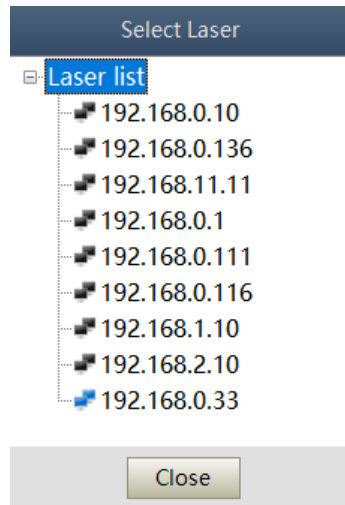

Figure 31 Multi-laser control interface

Select IP address of each laser, then double click. Raycus Laser Control System will communicate with the selected laser. After the communication is established, the lower left status display area will show that the network connection is “OK”, as Figure 32.



Figure 32 Communication status interface between rlcs and the laser

8.2.1 Add/DeleteLaser

Users can add/delete laser in the laser list area by right-click to add/delete In the Raycus Laser Control Software. Users need to type the IP address of laser to add a new laser. Detailed operation is shown in Figure 32 and 33.

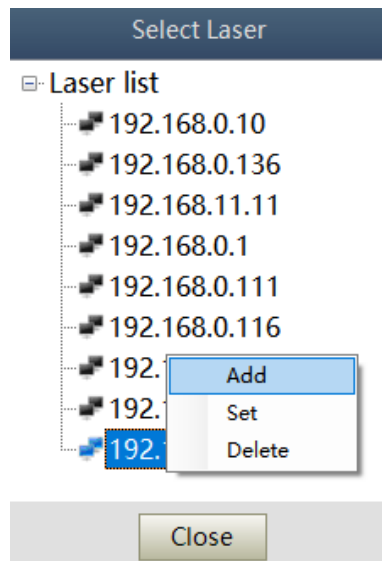

Figure 33 Adding the fiberlaser

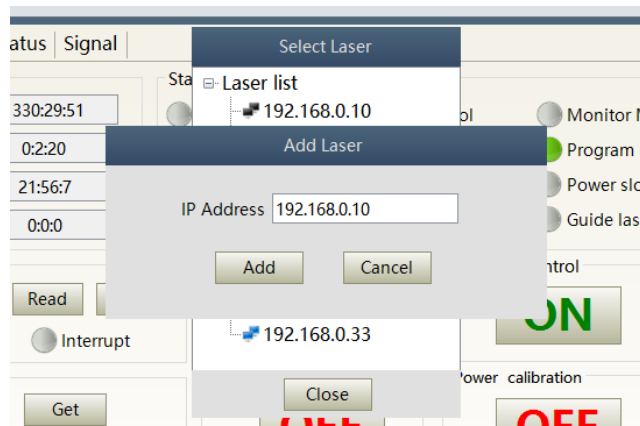

Figure 34 Procedure for Adding the IP Address to Laser

8.2.2 Delete Laser

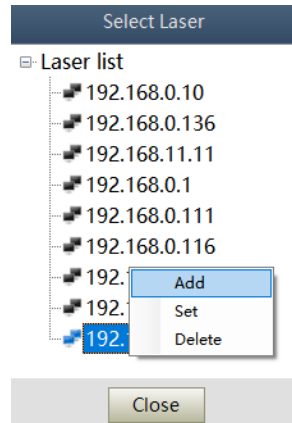

Figure 35 Delete laser

8.2.3 Modify Laser IP

After the laser has established a connection, select the IP address of the current laser, right-click“Set”.

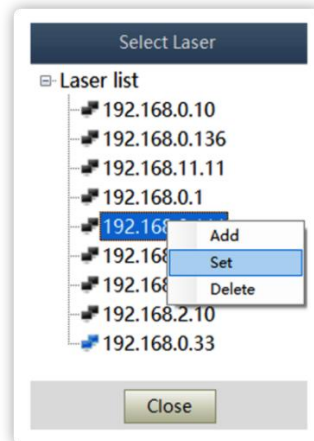

Figure 36 Change the IP address of laser

In the pop-up “Laser Configuration” window, enter the IP address of the laser Users want to modify, click “Set”, and a “Setup successful” prompt box pops up. After Users click “Confirm”, the prompt box disappears. Click the “Cancel” button on the “Laser Configuration” interface, the “Laser Configuration” window disappears, and the IP address is successfully modified. See Figure 36 and 37 for specific steps.

After modifying the laser IP address, the laser will disconnect from the network. At this time, power on again, click “Select Laser”. In the IP address list in the pop-up “Laser Configuration” window, double-click the laser IP address users just modified. The connection display is normal, as Figure 37.

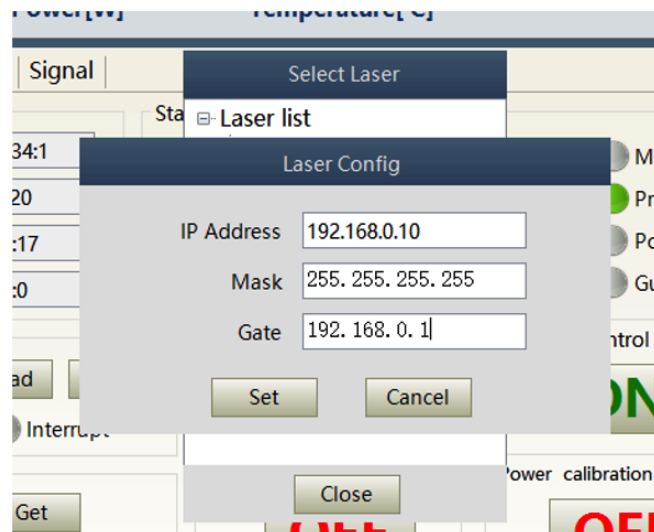

Figure 37 Modify the IP address of laser

8.3 Main Working Status Display

The uppermost part of the main interface of the laser is the main status display area of the laser, which mainly displays the current laser emitting power percentage, actual emitting power, current laser temperature and other information. See Table 12 for details.

The laser’s main status display is as Figure 38 and Table 12.

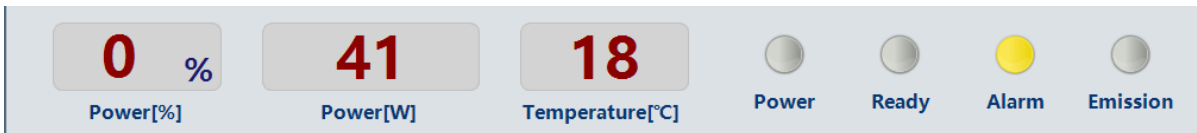

Figure 38 A diagram of the laser's main display area

Table 12 The laser main display content and meanings

Display	Meanings
Emission power	current setting percentage of power in real time
Emission power	Average laser emission power in real time (W)

Laser temperature	Water cooling temperature in real time (°C)
Power light	Status of main power supply: green-main power supply is on gray-main power supply is off
Ready light	Indicates readiness of current laser: green-laser is ready gray-laser is not ready
Alarm light	indicates alarm status of current laser: yellow - laser is abnormal gray-laser is normal
Emission light	indicates the working model of the current laser: red-laser is in working model gray-laser is not in output model

8.3.1 Laser's Cumulative Operating Time Display Area

The laser's cumulative operating time display is shown in Figure 39. The cumulative start-up time, cumulative laser emission time, today's power-on time and today's lighting time can be displayed in hours, minutes and seconds respectively.

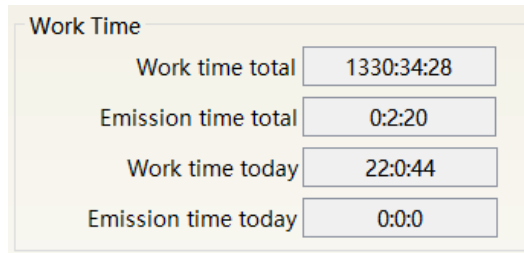

Figure 39 Laser cumulative operating time display interface

8.3.2 Laser Working Status Display Area

The laser working status display area is as Figure 40 and Table 13:

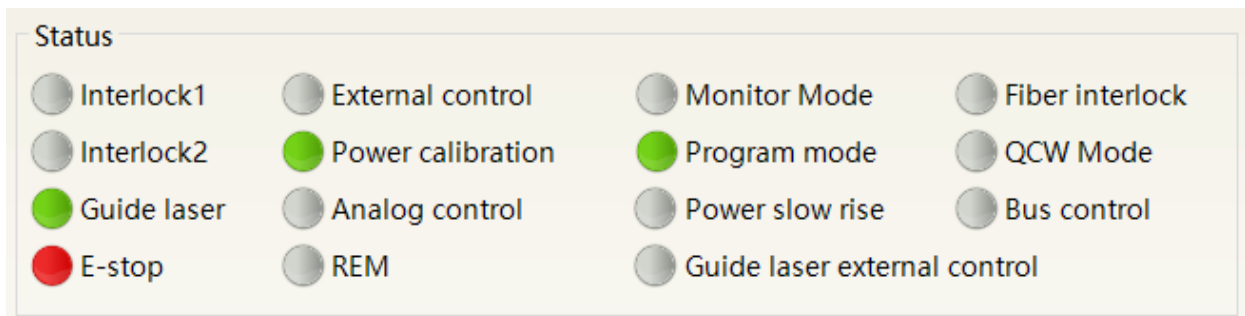

Figure 40 A diagram of the laser's working status display area

Table 13 The laser main display area clarification

Display	Content explanation
Emergency stop	Red: emergency stop button on front panel is pressed Gray: emergency stop button is reset
REM	Green: laser works in REM mode Gray: laser works in ON mode
Red laser external control	Green: laser works in red laser external control mode Gray: laser works in red laser internal mode. Laser on/off controllable by software
Red laser	Green: red laser is on Gray: red laser is off
Output fiber Interlock status	Green: Interlock spot at output fiber end is make Gray: Interlock spot at output fiber end is break
External control model	Green: Laser works in external control mode Gray: laser works in internal control mode. Laser on/off is controllable by software
Power correction	Green: Laser operates in power linear correction mode, in which control system automatically adjusts the laser's emission power. It makes the emission power linear, with a longer response time for AD analog in this mode, longer than 1mS. Gray: laser operates in non-correction mode, and the external 0-10V analog voltage is linear only with the current of the pump auxiliary tube. The response time for this mode AD simulation is less than 100uS
AD model	Green: Laser power is determined by the 0-10V analog voltage on XP4 when laser works in AD mode. Gray: laser power is set by Raycus Laser Control Software or communication commands.
Monitoring model	Green: Raycus Laser Control Software is in monitoring mode. Users can monitor laser status only, but not able to take control of laser. Monitoring model is activated when interface 10001 of laser occupied. Gray: Raycus Laser Control Software operate in normal mode
InterLock1 make	Green: XP2 leg 17,18 on safety interface make Gray: XP2 leg 17,18 on safety interface break
InterLock2 make	Green: XP2 leg 19,20 on safety interface make Gray: XP2 leg 19,20 on safety interface break
Programming model	Green: Laser is in program mode Gray: Laser is not in program mode
Power slow rise & fall mode	Green: laser works in power slow rise & fall mode Gray: laser does not work in power slow rise & fall mode

8.3.3 Laser Power-up, Mode Selection, Laser Emission Control Area

Laser power-up, mode selection, laser emission control display area is as Figure 40, the display content is as in Table 14.

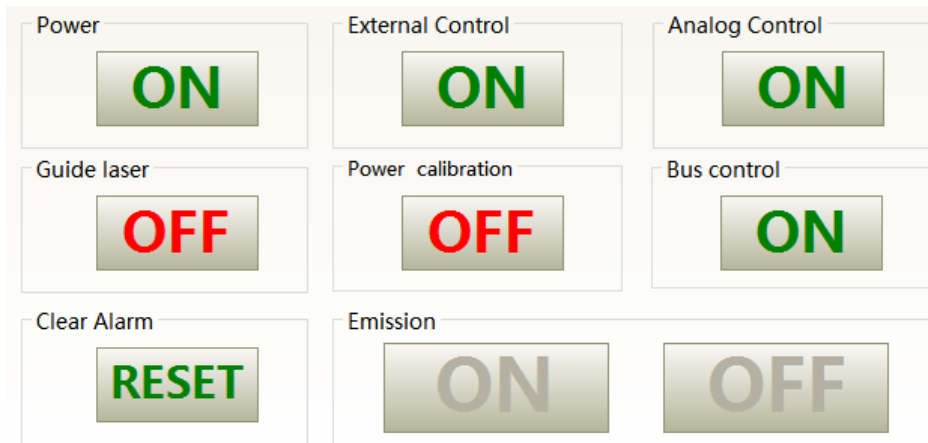

Figure 41 Laser power-on, mode selection, laser emission control display area

Table 14 Laser power-on, mode selection, laser emission control display area explanation

Display Content	Explanation
Main power button	Click ON, main power on Click OFF, main power off
External control mode	Click ON, activate laser external control Click OFF, shut laser external control Mode power-off memory automatically
AD mode	Click ON, AD analog mode on Click OFF, AD analog mode off Mode power-off memory automatically
Red guide beam	Click ON, guide laser on Click OFF, guide laser off
Power correction	Click ON, activate laser power correction mode Click OFF, shut laser power correction mode Mode power-off memory automatically
Eliminate alarm	Eliminate current laser alarm
Laser ON	Laser is in output
Laser OFF	Laser is off

8.3.4 Programming Mode Test Area

The laser programming mode test area interface is as Figure 42, in which the “Set” button is used to test the waveform of the programming mode. This function can only run internal mode (when external mode is turned off). Enter the current pre-tested waveform number in the digital text box and click the “Set” button.

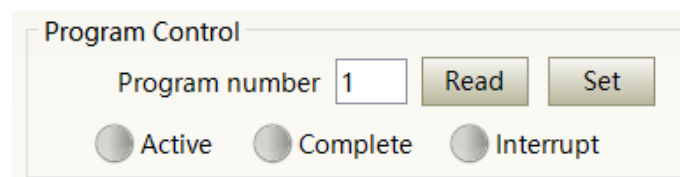

Figure 42 Laser programming mode test area display interface

8.3.5 Power Slow Rise & Down Parameter Setting Area

Ramping time

Rise time ms

Fall time ms

Figure 43 Slowrise and fall parameterarea

Click to read parameters, users can read the power rise and fall time stored in the laser. Click on set parameters to set new power rise and fall times.

When the rise and fall time are all set to 0, the power ramp-up and ramp-down function is automatically turned off; when one is not 0, the ramp-up and ramp-down function is automatically turned on, for example:

Ramping time

Rise time ms

Fall time ms

Figure 44 Slow rise and fall setting

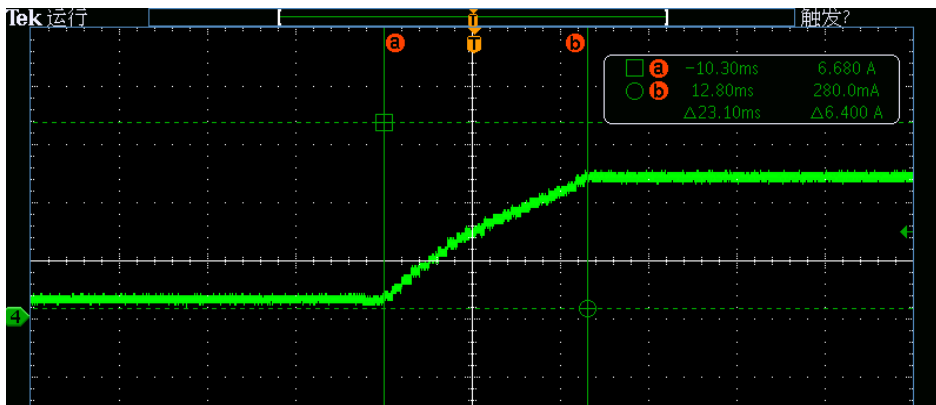

Figure 45 The power ramping time rise

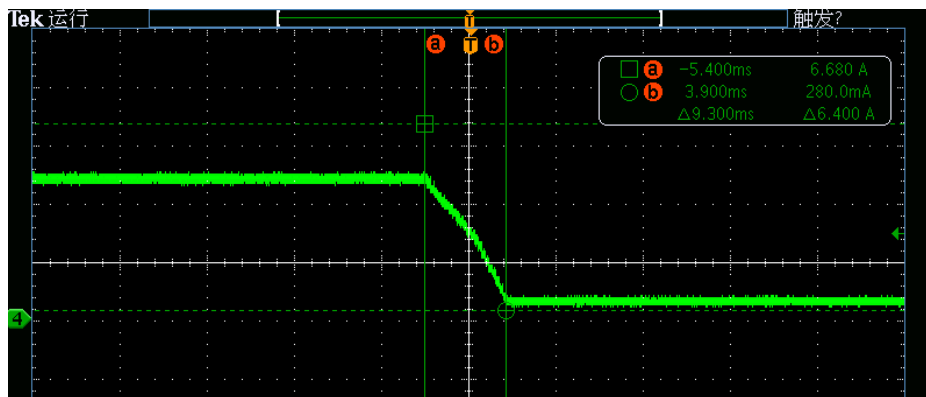

Figure 46 The power ramping time fall

8.3.6 Laser Emission Parameters Read the Settings Area

Laser emission parameter setting interface is as Figure 47. The emission parameter setting is not valid when AD mode is on.

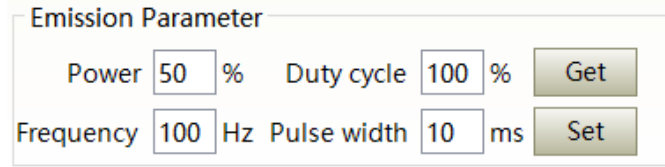

Figure 47 Laser emission parameter setting area display interface

The power is invalid when the AD mode is turned on;

The relationship between the frequency, duty cycle and MOD of the laser emission parameters when the laser is externally controlled;

When the duty cycle is 100%, the actual laser emission is strictly synchronized with the external MOD signal, and the default duty cycle is 100% after power-on.

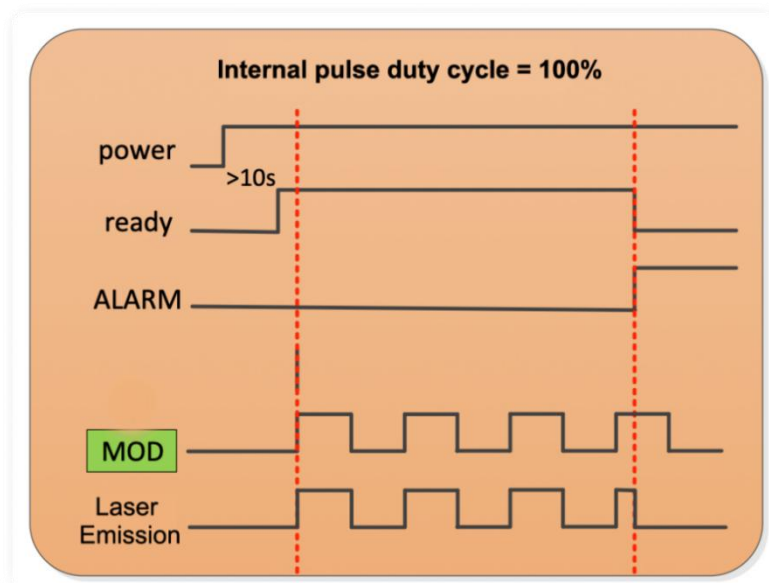

Figure 48 The output waveform of the laser when the internal pulse duty cycle is 100%

When the duty cycle is less than 100%, the actual laser emission is equal to the phase sum of the external MOD signal and the internal frequency.

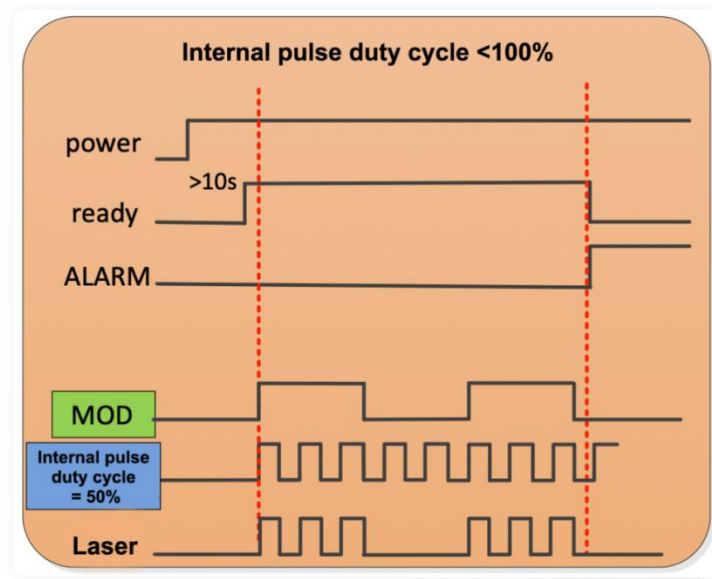

Figure 49 The output waveform of the laser when the internal pulse duty cycle is less than 100%

8.4 Laser parameter Display Area

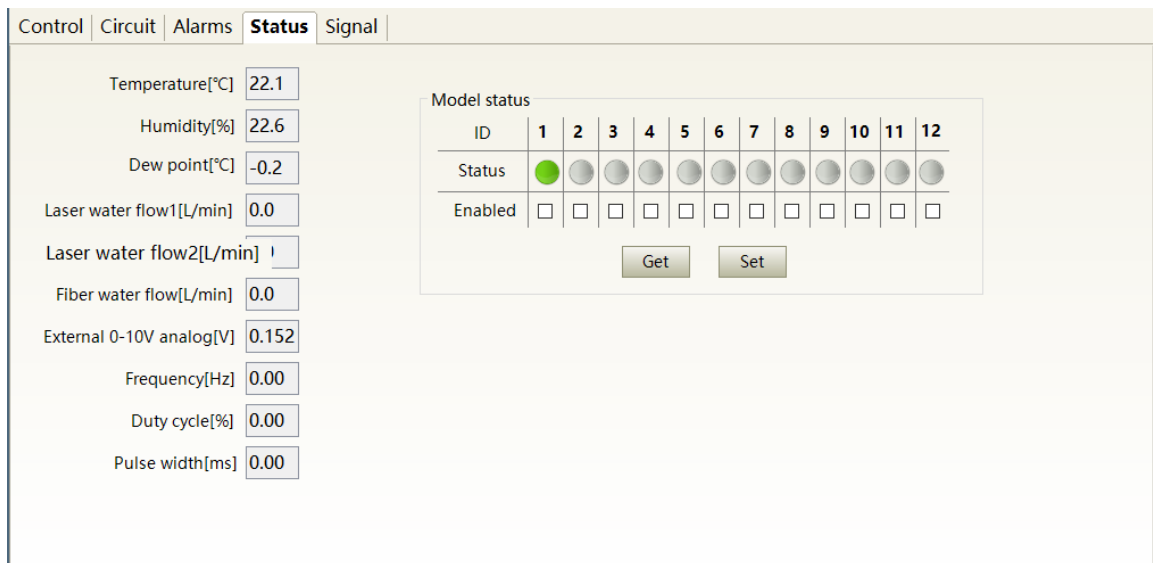

Figure 50 Laser parameter display area display interface

Module Status: The display interface for laser parameter display area is as Figure 49. The module status is used to shield the faulty module, the green light indicates the number of modules installed inside the current laser, and the check box indicates the module that is actually running in the current laser.

8.5 Alarm Type Display Area

The laser alarm type display area interface is as Figure 50. This interface shows the cause of the alarm for the current laser.

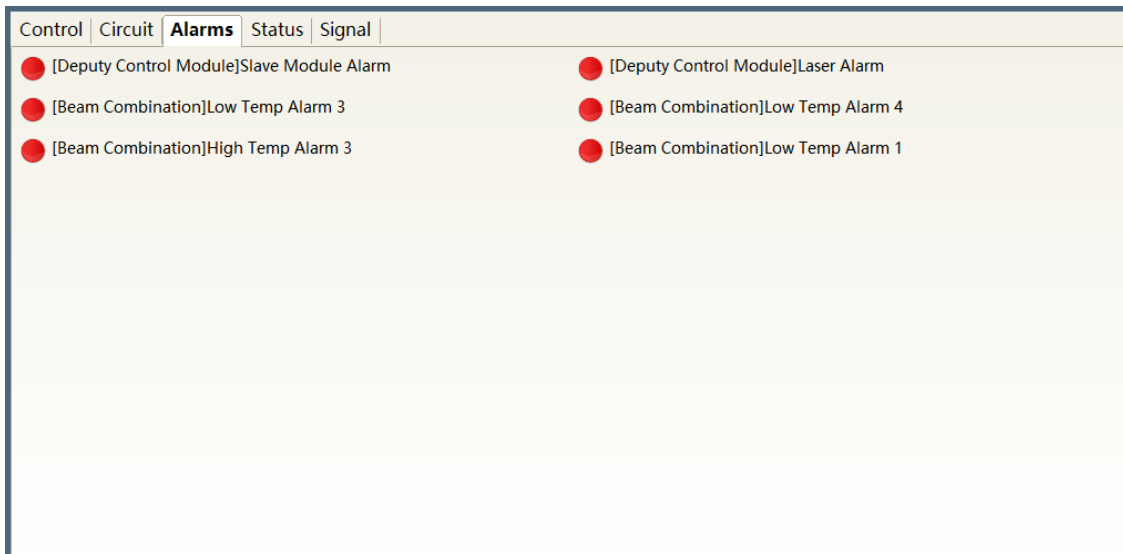

Figure 51 Laser alarm type display area interface

8.6 Ring Light Parameters Setting

Click the Ring Spot tab to enter the Ring Spot Settings page, as shown in Figure 52 below. The power bar shows the maximum power and current set power of the laser, the center power bar shows the maximum power and current set power of the laser center light, and the ring power bar shows the maximum power and current set power of the laser ring light. The current power of the laser is calculated automatically according to the parameters set by the center light and ring light. Users can set the ratio of the center light to the ring light according to their needs (click on \pm) or drag the slider bar), and then synthesize the light output parameters set by the main interface to get the desired ring laser output. Take the 6kW laser as an example, if the center power is 71%, ring power is 56% (that is, the center power is $4000 \times 0.71 = 2840\text{W}$, ring power is $2000 \times 0.56 = 1120\text{W}$), then the total power output of the laser is 3960W (that is, 66% of the maximum power of the laser) If the power of the light output parameter is 50% in the main interface, then the actual light output power needs to be *50% again, that is, the actual light output power is 1980W, with the center light accounting for 1420W and the ring light for 660W.

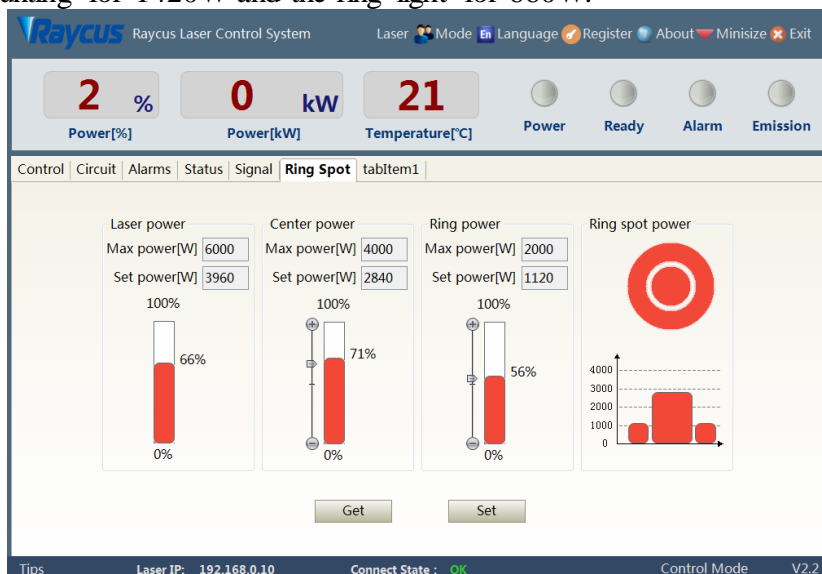

Figure 52 Ring light parameters setting page

8.7 Raycus Laser Control Software Operating Mode Selection

The laser operating mode is set by the Raycus Laser Control Software. Its operating interface is as Figure 53. The interpretation of the various patterns can be found in Table 15.

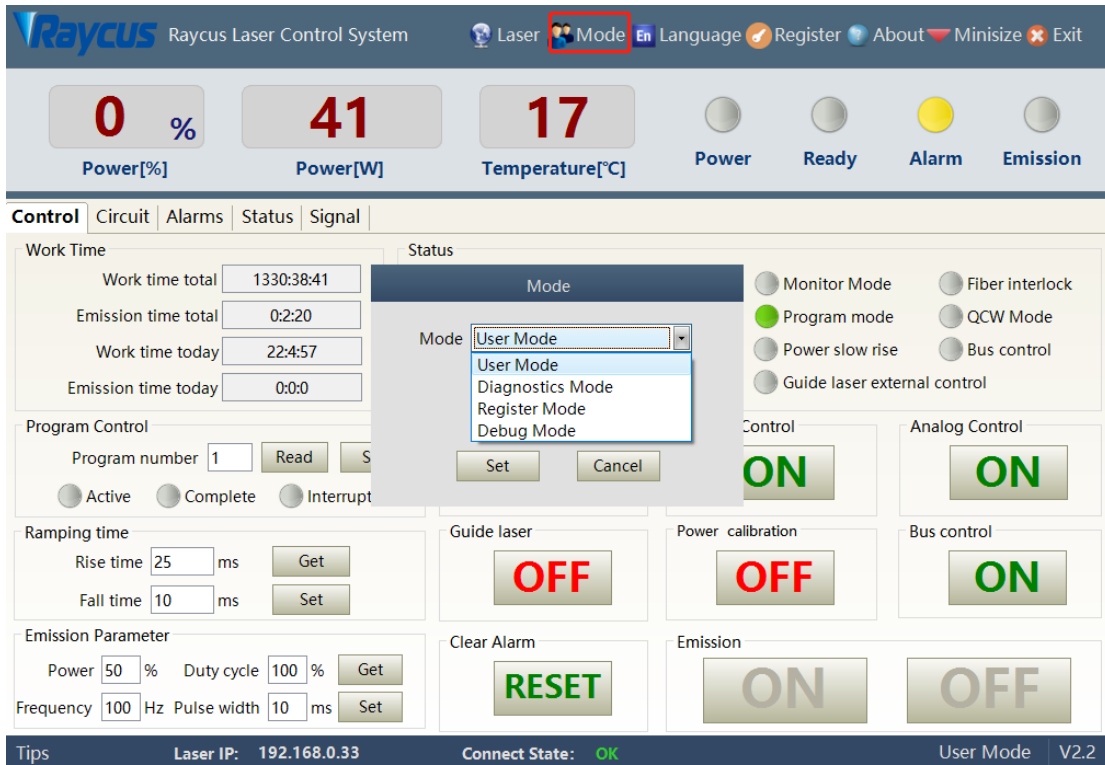

Figure 53 Laser operatingmode selecting

Table 15 Laser operatingmode and explanation

Mode selection	Mode explanation
User mode	A concise software interface
Diagnostic mode	Displays laser’s all status and parameters for diagnosis purposes
Authorization	Time-limited locking function can be set on laser
Debug mode	Users can modify laser parameters (subject to valid password)

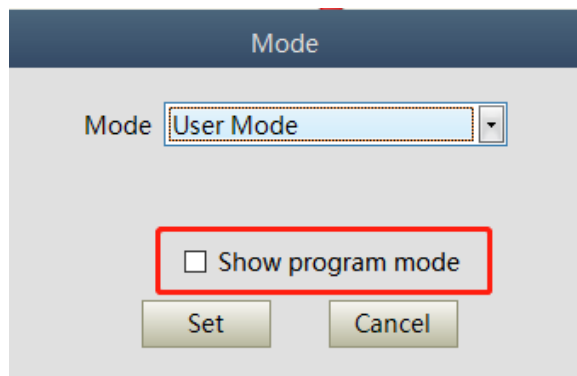

Figure 54 The display area interface of the usermode selecting

The waveform editing interface is displayed on the software only when programming mode is selected.

8.8 Language

Laser language selection interface is as Figure 55. Users can choose between Simplified Chinese and English by click “Language”. Setting effective after Raycus Laser Control System restarted.



Figure 55 Language selection interface

8.9 Authorization (Time-limited Locking)

8.9.1 Authorization in UserMode

The authorization settings in user mode are as Figure 56. Laser can be locked and unlocked by valid authorization code.

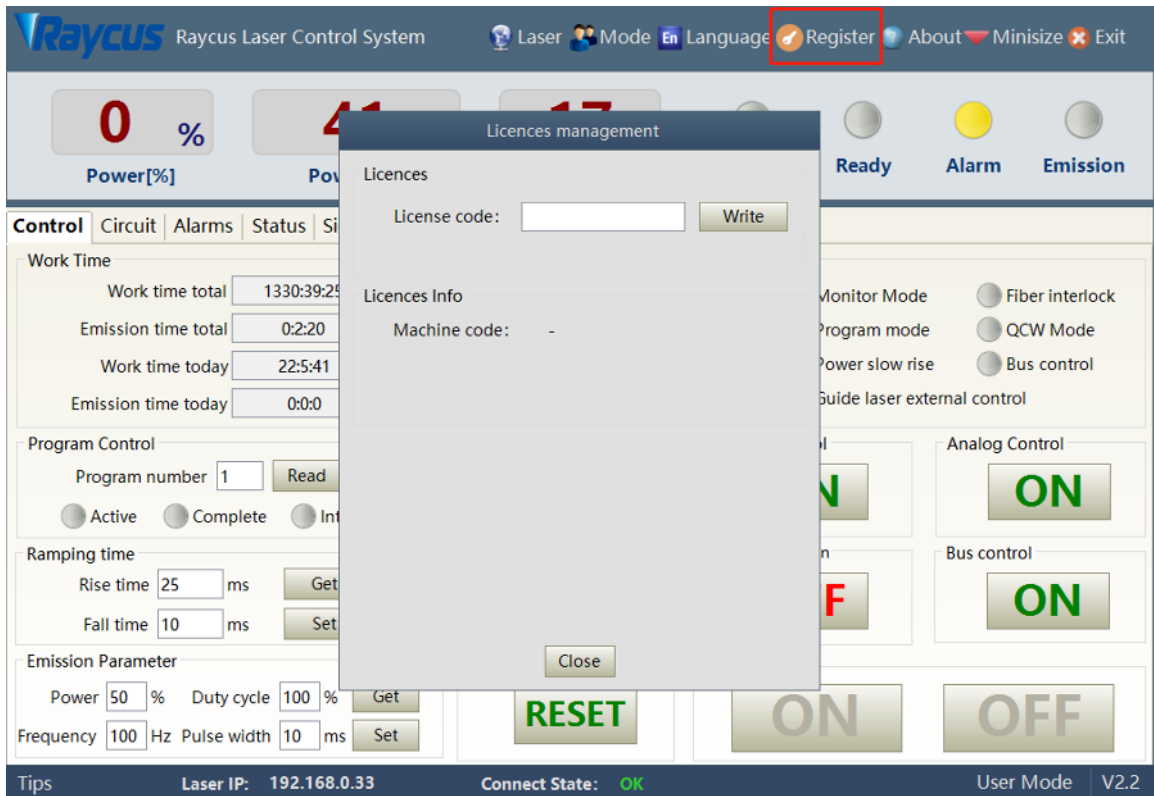

Figure 56 The authorization settings operating interface in usermode

8.9.2 Authorization in Authorization Mode

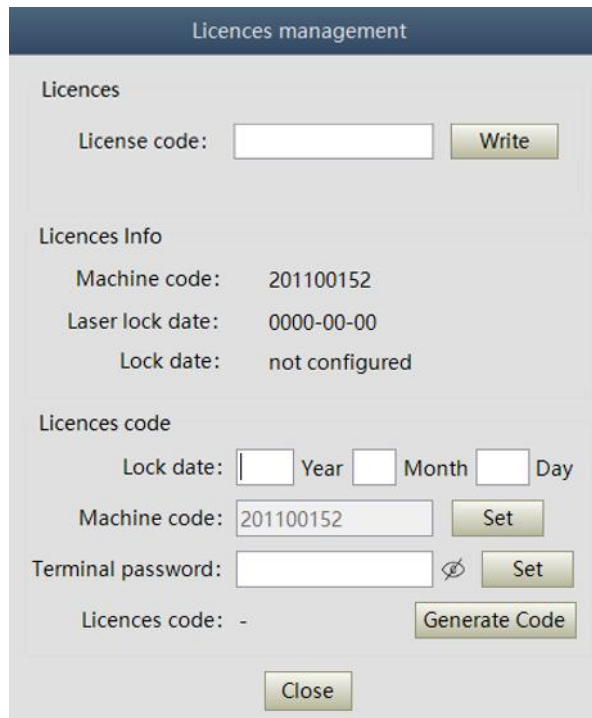

Figure 57 Authorization settings operating interface in authorization mode

The authorization settings in laser authorization mode are as Figure 55. This interface allows the users

to lock and unlock the machine and can also be used as an authorization code generator.

The locking time setting can set the effective using time of laser. For example, the locking time: May 21, 2020, indicating that the laser is locked until 0:00 on May 21, 2020, 0/0/2000 means the laser is permanently unlocked.

The terminal password is set for the laser locking party. The terminal code can only be set once, and no modification is allowed after its set. The terminal password is 8-byte, e.g., 0123456789ABCDEF, no other characters are allowed.

The terminal password is set for the laser locking party, and the terminal code can only be set once, and it is not allowed to be modified after setting once. The terminal password is 8-byte hexadecimal, for example: 0123456789ABCDEF, other characters are not allowed.

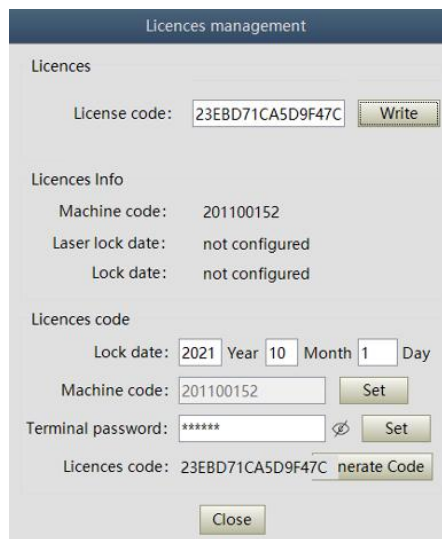

Figure 58 Generate authorizationcode

Click and generate authorization code, and the software will automatically calculate the authorization code. Then click to set the authorization time to realize the time limited locking of the laser.

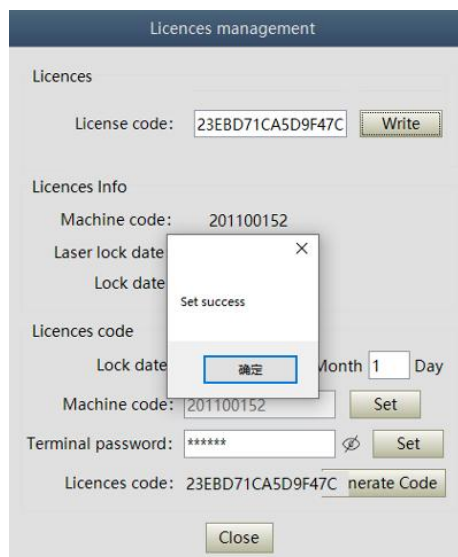

Figure 59 Lock set successfully

8.10 About

Laser relevant information such as date of manufacture, model, serial number, controlling serial number, token version number, system information and other information can be queried in the Raycus Laser Control System“About” item. Specific interface is as Figure 60.

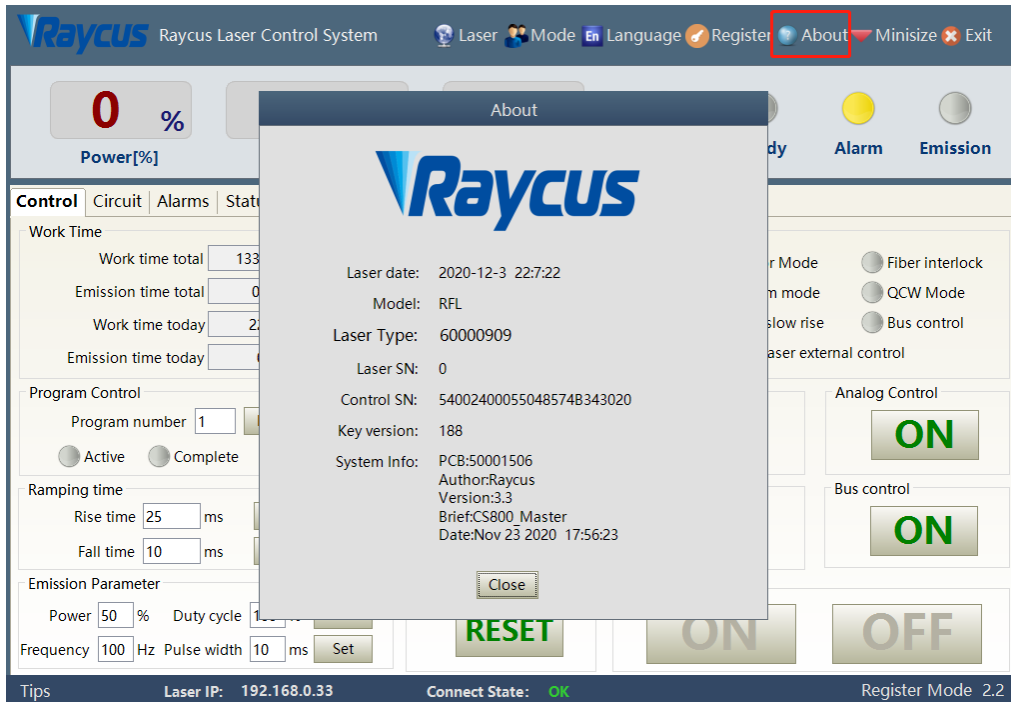

Figure 60 Laser relevant information query interface

XP1 Interface Status Indication (in DiagnosticMode)

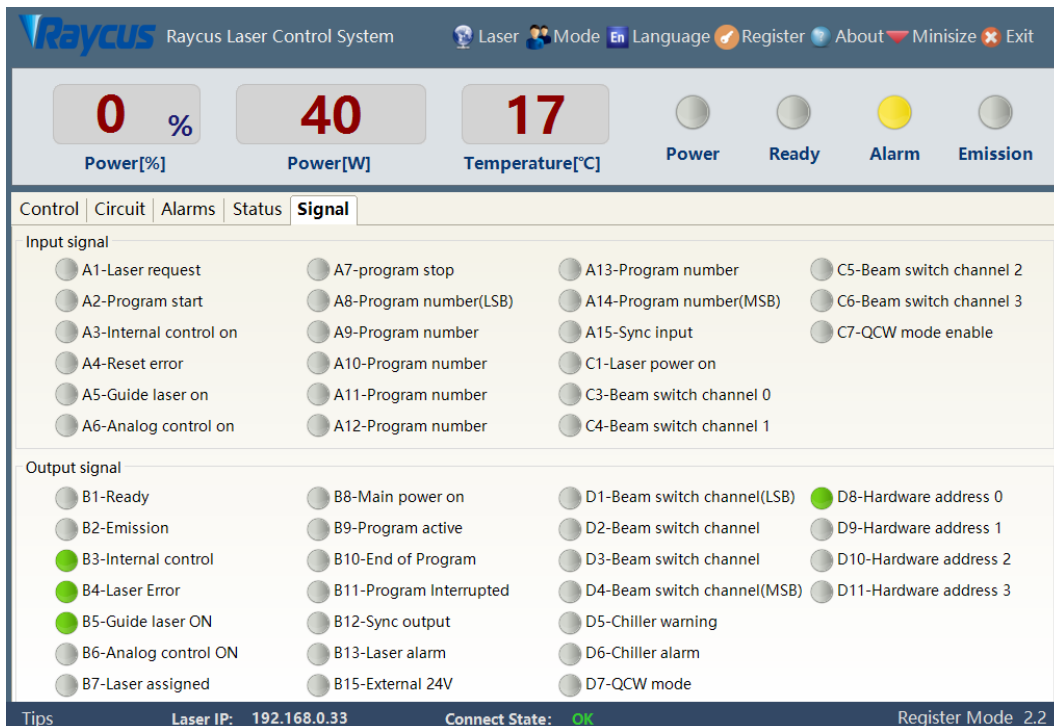

Figure 61 The XP1 interfaceview

The laser interface status indicator interface is as Figure 61. It is convenient to view the interface status information which represents the input and output status of the XP1 interface on the back panel.

8.11 Log (in DiagnosticMode)

Laser’s working log interface is shown as Figure 62. Users can query work log by entering the time to query and click on the “Search” button.

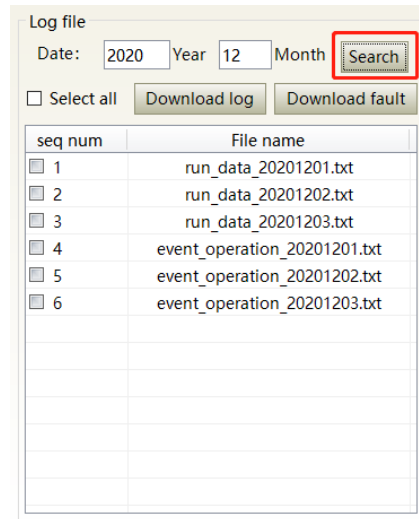

Figure 62 Laser’s workingloginterface

8.11.1 Download Log

Log download interface is shown as Figure 63.

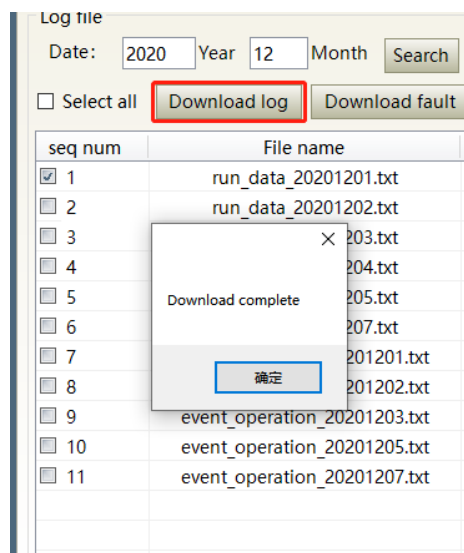

Figure 63 Logdownloadinterface

8.11.2 Download Record of HistoricalFault

Historical fault record download interface is shown as Figure 64.

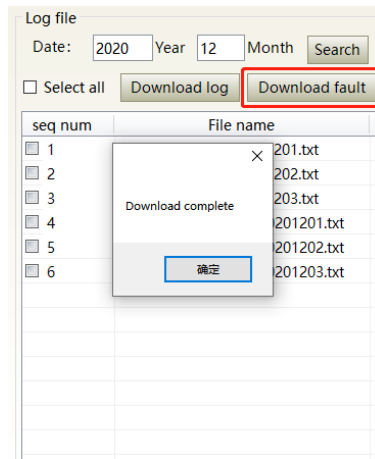

Figure 64 Historical fault record download interface

8.11.3 Downloaded File Address

The file address query interface for all download information is as Figure 65.

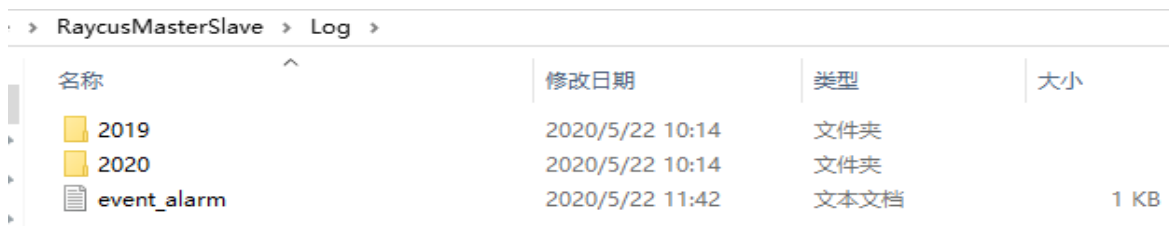

Figure 65 The file address query interface for all downloaded information

8.12 Module Parameters (in Diagnostic Mode)

Laser module parameter query interface is as Figure 66. The interface is for the parameter query in diagnostic mode from which Raycus technicians can analyze the cause of laser anomalies.

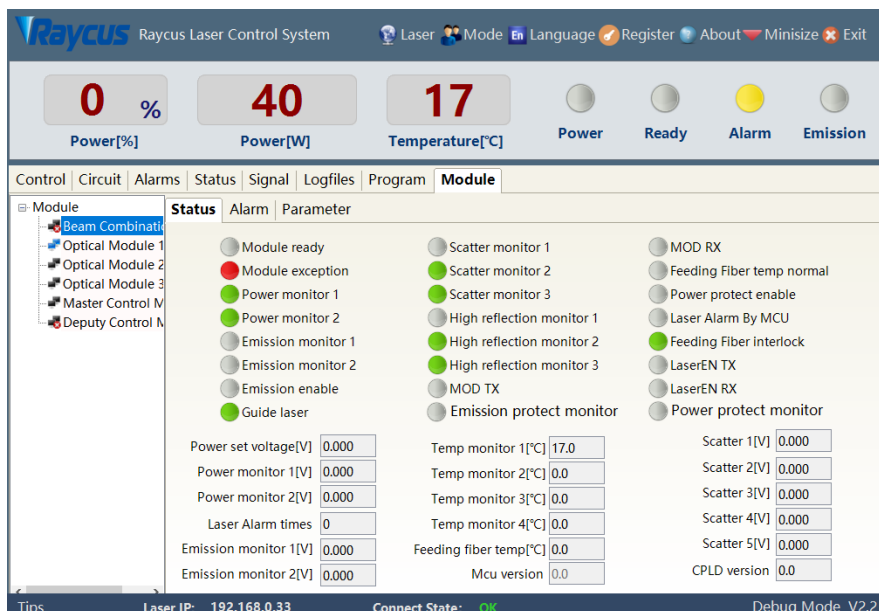

Figure 66 Module parameters query interface in diagnostic mode

8.13 Programming Settings (Waveform Editing)

The laser programming settings interface is as Figure 67.

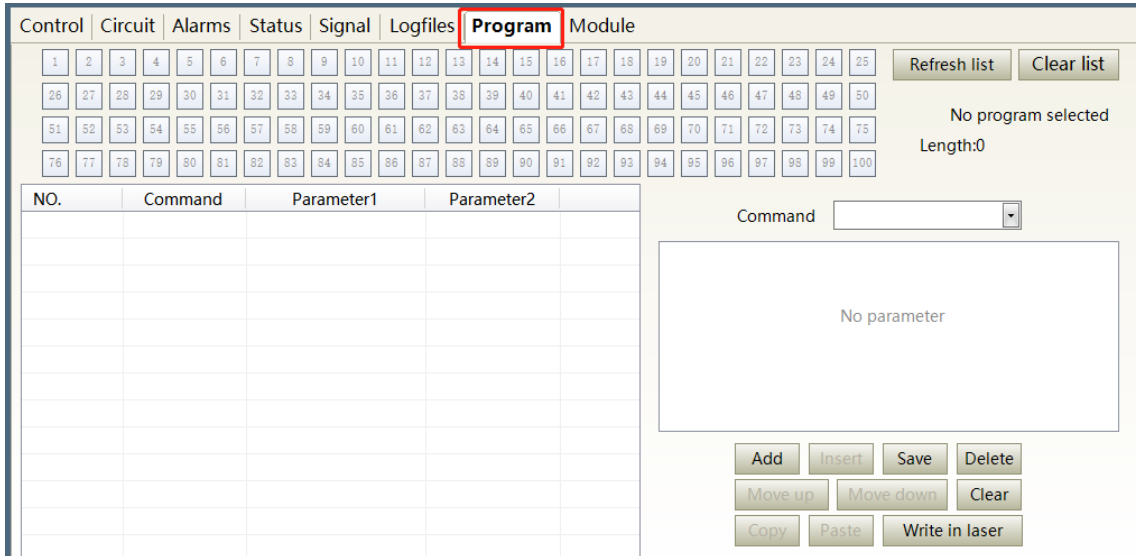

Figure 67 The programming interface in waveform editing mode

8.13.1 View the Number of WaveBars Inside the Current Laser

Operating interfaces of view the number of wave bar stored inside the current laser is as Figure 68. The software automatically lists the number of wavelength bars that have been saved by click on the “Refresher List” button. Green indicates the bar already has a program and white indicates that the bar is empty.

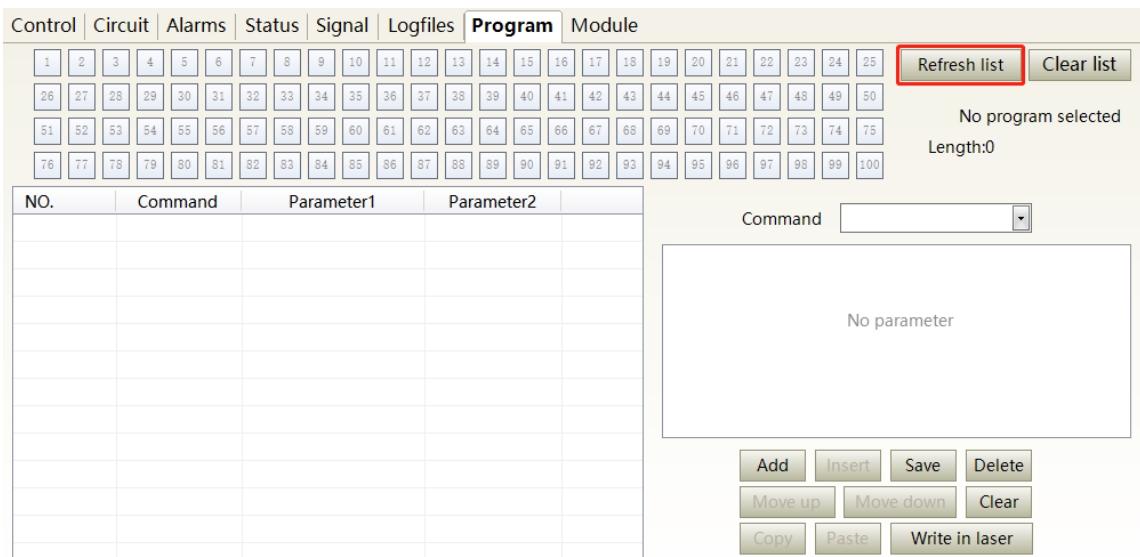

Figure 68 Operating interfaces of wavebar stored inside the current laser

8.13.2 Check Waveform Content

To check the waveform contents in the current laser waveform mode is as Figure 69. The program automatically lists the original waveforms by click the waveform number that needs to be checked.

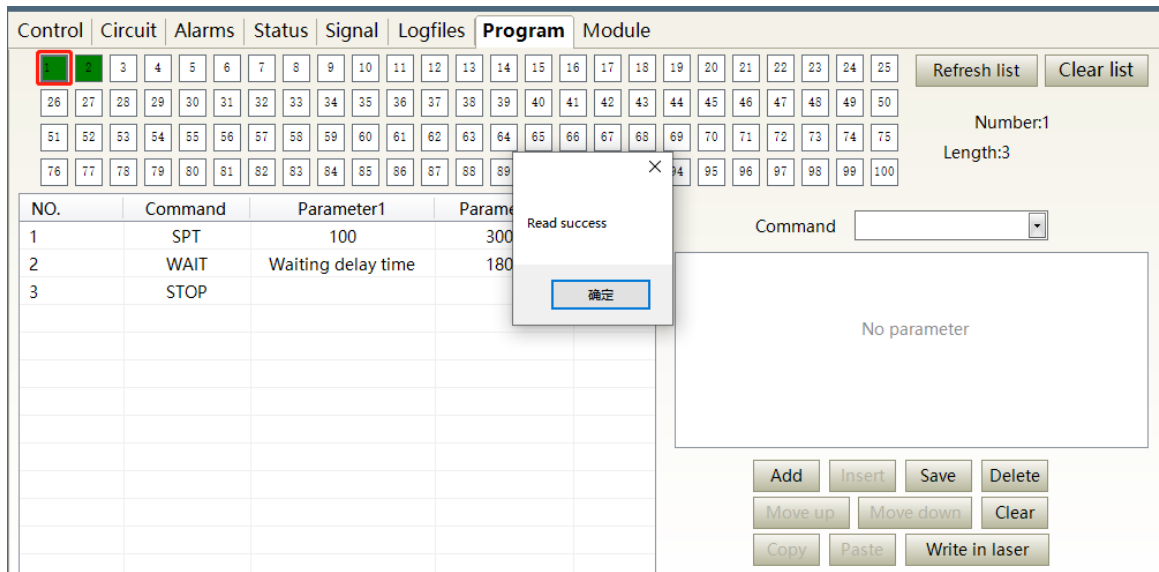

Figure 69 Waveform content interface in the current laser wave formmode

8.13.3 Empty All Waveforms

Empty all waveform interfaces stored in the current laser waveform mode is as Figure 70. All waveforms stored inside the current laser. will emptied by click “Empty Program List”.

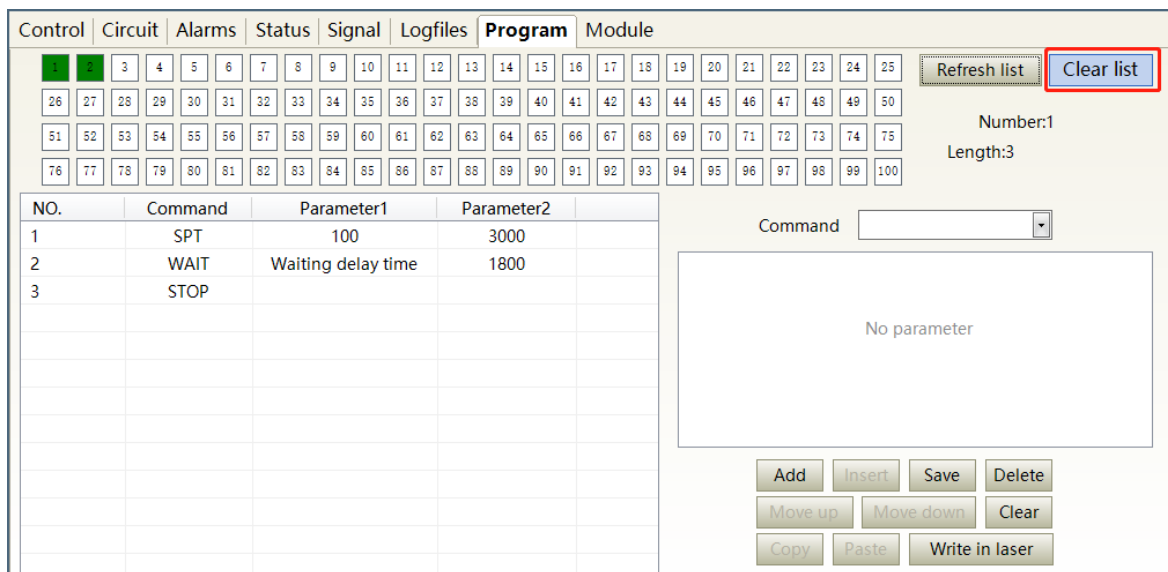

Figure 70 Interface of empty all waveform stored in the current laser waveform mode

8.13.4 Edit Waveform

Waveform editing when the laser is working in waveform mode is shown as Figure 71~75.

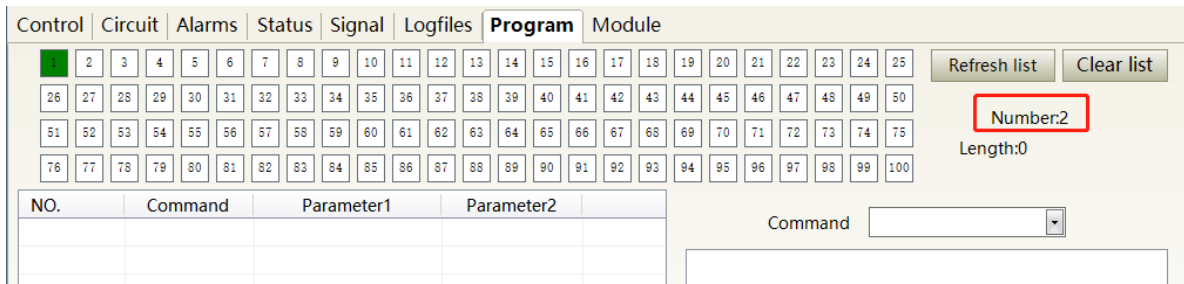

Figure 71 Step 1: Left click the pre-edited waveform number

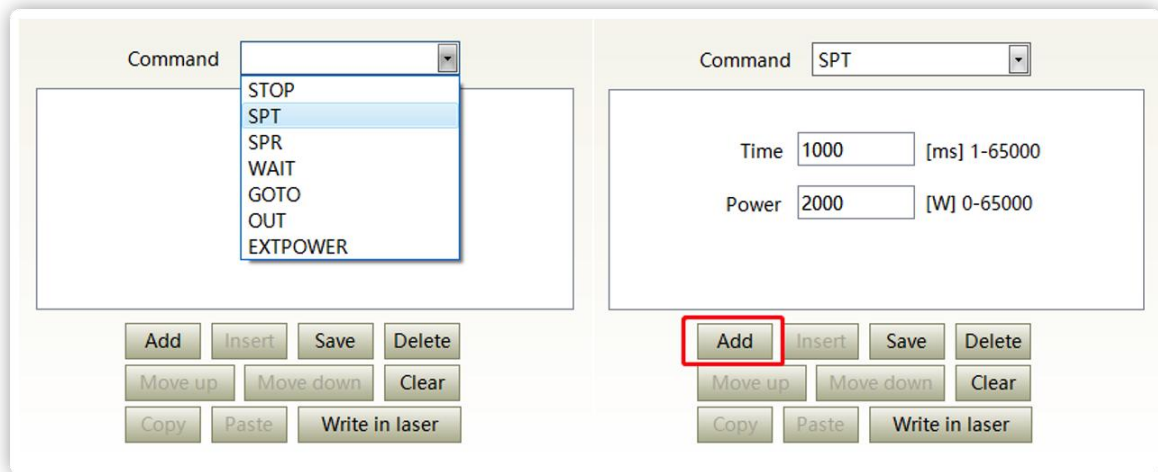

Figure 72 Step 2: Select the command under the command type, click “Add”

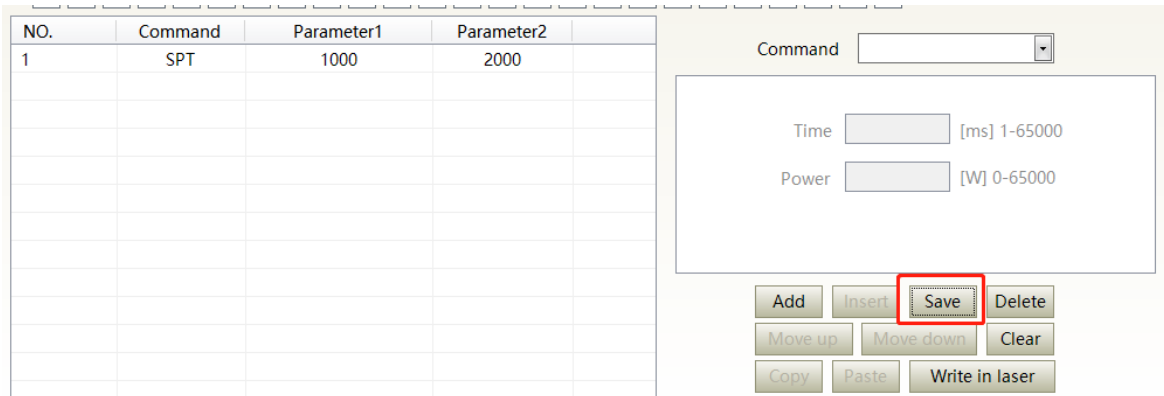

Figure 73 Step 3: Enter the parameters and click “Save”

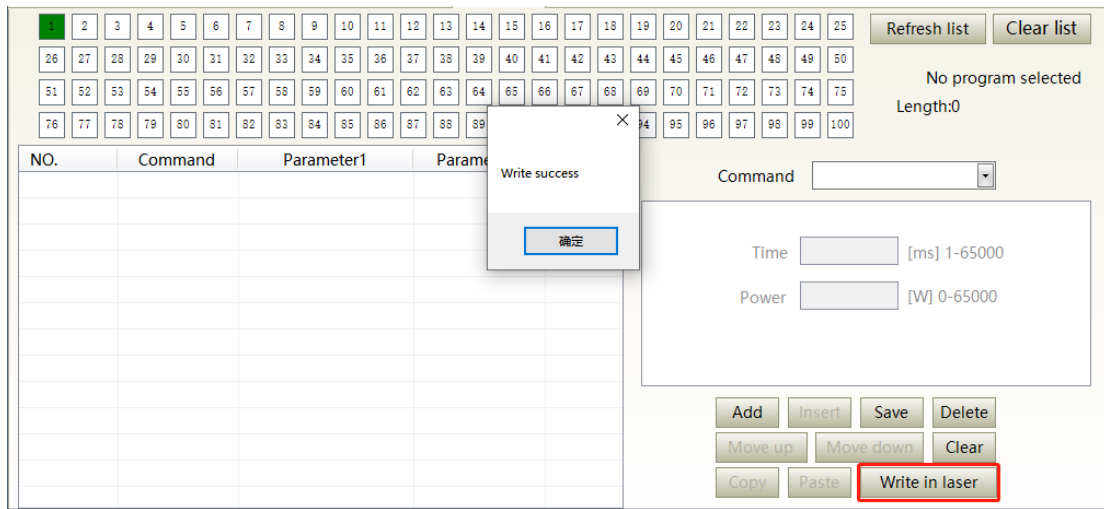

Figure 74 Step 4: After editing all commands, click“Write Laser”

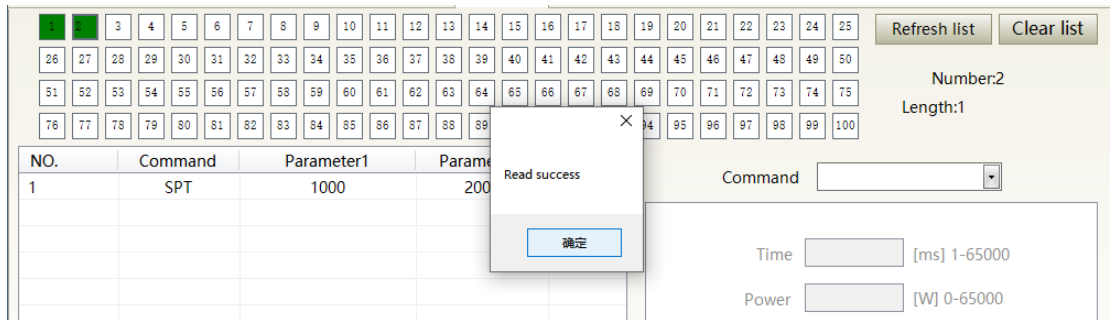

Figure 75 Step 5: New waveform number will turn green when users re-click the“RefresherList”

8.13.5 Command Explanations

Table 16 Command explanations in laserworkingstatus

Code (1 Byte)	Parameter1(2 bytes)	Parameter 2 (4 bytes)	Note
1 Stop	none	none	The program end command. the last command must be this command.
2 SPT	0~65000 (ms)	0~65000W	Change power to 2 in time 1
3 SPR	0~65000(W/ms)	0~65000W	Change power to 2 in power change ratio 1
4 WAIT	1 Wait for sync signal low level	Null	
	2 Wait for sync signal high level	Null	
	3 Wait for sync signal rising	Null	

		4	Wait for sync signal dropping	Null		
		5	Wait	0~65000ms (int)		
5	GOTO	0 ~ 99	line	-1	Switch at low sync signal	Jump to different line when comply
		0 ~ 99	line	-2	Switch at high sync signal	Jump to different line when comply
		0 ~ 99	line	0~1000000	Switch at waiting time due	Jump to different line when comply
6	OUT	1	SO	1	sync signal low level output	
				2	sync signal high level output	
7	EXT Power	1	0~10V			
		2				

9 Warranty, Repair and Return

9.1 General Warranty

Raycus guarantees the products with material and technical problems and guarantees that they meet the specifications under normal use.

Raycus has the right to selectively repair or replace any product that has a material or technical problem during the warranty period. All products repaired or replaced during the warranty period only provide free warranty services for products with special problems. Raycus reserves the right to collect payment for products that have problems under normal use.

9.2 Limitations of Warranty

The warranty does not cover the maintenance or reimbursement of our product of which the problem results from tampering, disassembling, misuse, accident, modification, unsuitable physical or operating environment, improper maintenance, damages due to excessive use or not following the instructions caused by those who are not from Raycus. The users have the responsibility to understand and follow this instruction to use the device. Any damage caused by fault operating is not warranted. Accessories and fiber connectors are excluded from this warranty.

According to the warranty, client should inform us within 30 natural days after the defect is discovered. This warranty does not involve any other party, including specified buyer, end-users and any parts, equipment or other products produced by other companies.

	<p>WARNING: It is the users' responsibility to understand and follow operating instructions in this User Guide and specifications prior to operation-failure to do so may void this warranty. Accessories and fiber connectors are not covered by this warranty.</p>
---	---

9.3 Service and Repair

DO NOT open the device. There are no user serviceable parts, equipment, or assemblies for user in this product. All service and maintenance shall be performed by qualified Raycus personnel or the parties that authorized by Raycus.

Please contact Raycus as soon as possible when problems under warranty about maintenance happened to the product.

The product returned with permission should be placed in a suitable container.

If any damage happened to the product when receiving the goods, please notify the carrier in written format immediately.

NOTE:

Raycus reserve the rights to make modifications in the design or constructions of any model of our products at any time without incurring any obligation to make changes or install the same modifications on the units previously purchased and delivered.

All the items within the warranty and service clauses specified as above and to be provided by Raycus are for users' reference only; the formal contents about warranty and service are subject to the contract to be signed between Raycus and its users.

Information contained in this document is subject to change without notice.