



Raycus User Guide for Blue Light 500W Fiber Delivered Direct Diode
Laser
RFL-B500D

Wuxi Raycus Fiber Laser Technologies Co., Ltd.

TABLE OF CONTENTS

| | |
|--|-----------|
| 1 Safety Information | 1 |
| 1.1 Safety Identifiers | 1 |
| 1.2 Laser Safety Grade | 1 |
| 1.3 Security Identifiers | 2 |
| 1.4 Optical Safety | 3 |
| 1.5 Electrical Safety | 3 |
| 1.6 Other Safety Precautions | 3 |
| 2 Product Description | 4 |
| 2.1 Features | 4 |
| 2.2 Model Description | 4 |
| 2.3 Packing Lists | 5 |
| 2.4 Unpacking and Inspection | 5 |
| 2.5 Operation Environment | 6 |
| 2.6 Attentions | 7 |
| 2.7 Performance | 8 |
| 3 Installation | 11 |
| 3.1 Overall Dimensions | 11 |
| 3.2 Size and Installation of Output Head | 12 |
| 3.3 Cooling System installation and Requirements | 13 |
| 3.4 Installation Precautions | 14 |
| 4 Using the Product | 16 |
| 4.1 Front and Rear Panel | 16 |
| 4.2 Power Connection | 18 |
| 4.3 Interface Definition | 19 |
| 4.3.1 Service Safety Iinterface | 19 |
| 4.3.2 MOD Modulation signal Interface | 19 |
| 4.3.3 CTRL-INTERFACE | 21 |
| 4.3.4 RS-232 Serial Port..... | 23 |
| 4.3.5 Ethernet TCP / IP interface and Connection Steps | 23 |
| 4.4 Laser Working and Control Mode | 26 |
| 4.5 Start Operation Sequence | 26 |
| 4.6 Control Mode Selection | 26 |
| 4.6.1 External RS232 Control Mode Wiring Diagram..... | 29 |
| 4.6.2 External Control Mode Operation Process..... | 29 |
| 4.6.3 External Control RS232 Time Sequence Diagram | 30 |

| | |
|---|-----------|
| 4.6.4 External Control AD Wiring Diagram | 31 |
| 4.6.5 External Control AD Operation Process | 32 |
| 4.6.6 External Control AD Time Sequence Diagram | 33 |
| 4.6.7 Inner Control Mode Wiring Diagram | 33 |
| 4.6.8 External Control AD Operation Process | 34 |
| 4.6.9 Inner Control Mode Time Sequence Diagram | 34 |
| 4.7 Red Light Control..... | 35 |
| 4.8 Shut-down Operation Sequence | 35 |
| 5 Common Alarms and Solutions | 36 |
| 5.1 Alarm Display | 36 |
| 5.2 Alarm Processing | 36 |
| 6 Warranty, Return and Maintenance | 38 |
| 6.1 General Warranty | 38 |
| 6.2 Limitations of Warranty | 39 |
| 6.3 Service and Repair | 39 |

1 Safety Information

Thank you for choosing Raycus fiber delivered direct diode laser. This User Guide provides important safety, operation, maintenance and other information. Please read it carefully before using this product. To ensure safe and optimal operation of the product, please follow all warnings, cautions, operating procedures, and other instructions accordingly.

1.1 Safety Identifier

| | |
|---|--|
|  | ◆ WARNING: Describes a hazard that leads to a personal injury or death. |
|---|--|

| | |
|--|---|
|  | ◆ CAUTION: Describes a hazard that leads to a minor personal injury or product damage. |
|--|---|

1.2 Laser Safety Grade

According to Clause 9 from the European Community standards EN 60825-1, this series of lasers are classified as Class 4 laser. This product emits invisible laser radiation at or near wavelength of 450 nm, and the light power emitted by output head is more than 500W (depending on the model). Under such high power of laser radiation, it may cause damages to the eyes or skin directly or indirectly. Despite the radiation being invisible, the beam may cause irreversible damages to the retina and cornea. Appropriate and certified laser goggles must be worn at all times when the fiber laser is operating.

| | |
|---|--|
|  | ◆ WARNING: Users must wear appropriate laser goggles, while operating this device. The laser goggles are selected according to the range of wavelength emitted from this product. Users must ensure the protective range of laser goggles selected corresponds correctly with the range of laser wavelengths. Please do not directly view the laser output head when laser is powered on. |
|---|--|

| | | |
|--|------------------------------------|--|
| | | |
| <p>7: Class 2M laser Product – 1 m W red light(Chinese)</p> | <p>8: Electrical Hazard</p> | |

1.4 Optical Safety

Any dust on the end of the collimator assembly can burn the lens.

| | |
|--|--|
| | <p>◆ CAUTION: DO NOT emit when the protective cap is not opened, otherwise the lens or crystal will be damaged.</p> |
|--|--|

1.5 Electrical Safety

- 1) Make sure the product is firmly grounded through the PE line of the AC power cord.

| | |
|--|--|
| | <p>◆ WARNING: Any interruption from the protective earth will electrify the enclosure, which may result in personal injury for operators.</p> |
|--|--|

- 2) Make sure that the correct voltage of the AC power source is used.

| | |
|--|--|
| | <p>◆ CAUTION: Wrong wiring mode or power supply voltage will cause an irrecoverable damage to the laser device.</p> |
|--|--|

There are no devices that need to be used by operator in the laser. Please do not try to open the laser housing, otherwise it may cause an electric shock and the warranty will be invalid accordingly.

1.6 Other Safety Precautions

- 1) Do not directly view the laser output head when the laser is emitting.
- 2) Do not use the fiber laser in dark or dim environment.
- 3) If this device is used in a manner not specified in this document, the protection provided by the device may be impaired and the warranty will be voided.

- 4) There are no user serviceable parts, equipment or assemblies inside the product. All service and maintenance shall be performed by Raycus. In order to prevent electric shock, please do not break the seal or uncover the shield. Failure to comply with this instruction will void the warranty.

2 Product Description

2.1 Features

Raycus fiber delivered direct diode laser, compared with other lasers, has higher electro-optical conversion efficiency and lower power consumption. It is compact and ready to use. Because of flexible laser output mode, it can be easily integrated with system devices.

Main Features:

- Flexible cable output
- Highly reliable and long life
- Maintenance-free operations
- High Electro-optical Conversion Efficiency
- Easy to use control interface
- High modulation frequency
- High absorptivity of nonferrous metals

Applications:

- Copper Welding and cladding
- Soldering
- 3C and new energy
- Laser research

2.2 Model Description

The definitions of the model code for RFL-B500D fiber delivered direct diode lasers are shown in the table below:

Table 2 definition of model code

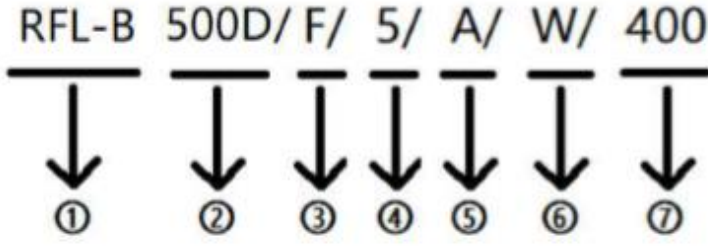
| | |
|--|--|
|  | |
| 1 | RFL-B represents blue light series laser |
| 2 | Power indicator, including 500W fiber delivered direct diode laser |
| 3 | Wavelength, 'B' represents a wavelength of 915nm, 'C' represents a wavelength of 976nm, 'D' represents 940nm, 'E' represents 808nm, 'F' represents 450nm |
| 4 | Cable length, unit meter, including 5 meters and 10 meters, also can be customized length |
| 5 | Output cable interface type: 'A' represents iHBQ interface, 'B' represents SMA905, 'C' represents D80 interface |
| 6 | Cooling method, 'W' stands for water cooling, 'T' represents TEC air cooling, 'A' stands for air cooling |
| 7 | Core fiber, unit is um |

2.3 Packing Lists

Please refer to packing lists located in the packing box.

2.4 Unpacking and Inspection

Raycus fiber laser is delivered with the specially designed package to offer the fiber laser maximal safety. Nevertheless, in order to prevent the occurrence of unpredictable circumstances during the transportation, please inspect all packaging once receiving the delivery. If you find any evidence of mishandling or damages, please keep the damaged material and contact the shipping agent and Raycus immediately.

Please double check if each listed content is inside the package; and contact Raycus as soon as possible if there are any issues.

Take extra care when removing the unit from the package to prevent the fiber optic cable from any collision and vibration. Please do NOT distort, bend or pull the output cable when unpacking the device; and avoid any collision to the head of laser output.

| | |
|---|---|
|  | <p>◆ CAUTION: The fiber optic cable and output head are precise optic instrument, ANY vibration or impact to the output head, and twist or excessive bend to the cable will damage the instrument.</p> |
|---|---|

2.5 Operation Environment

The operation conditions are listed in the following table:

Table 3: The Operation Environment Conditions for the Laser

| Requirements | Parameters |
|--------------------------|-----------------------|
| Model | 500 |
| Power Capacity (kW) | 2.5 |
| Installation Environment | Flat and no vibration |
| Ambient Temperature (°C) | 10~40 |
| Relative Humidity (%) | <70 |

Advice:

Place the laser in environments with air conditioning to ensure the laser operates in the best condition.

| | |
|---|---|
|  | <ul style="list-style-type: none"> ◆ Do not operate this product in the environment of high humidity (humidity > 95%). ◆ Do not operate this product in the environment of high temperature (temperature > 40°C). ◆ Do not allow this product to operate at a temperature below the ambient dew point. (As shown in Table 4) |
|---|---|

Table 4 Comparison table of constant dew point at ambient temperature and relative humidity

| Constant dew point table at ambient temperature and relative humidity | | | | | | |
|---|---------------------------|-----|------|-----|------|------|
| Ambient temperature (°C) | Maximum relative humidity | | | | | |
| | 20% | 30% | 40% | 50% | 60% | 70% |
| 20 | -3.5 | 2 | 6 | 9 | 12 | 14.5 |
| 25 | 0.5 | 6 | 10.5 | 14 | 16.5 | 19 |

| | | | | | | |
|----|-----|------|------|------|------|------|
| 30 | 4.6 | 10.5 | 15 | 18.5 | 21.5 | 24 |
| 35 | 8.5 | 15 | 19.5 | 23 | 26 | 28.5 |
| 40 | 13 | 20 | 24 | 27.5 | 31 | 33 |

The necessary moisture-proof treatment has been done in the design of the laser, but the serious condensation effect can not be completely avoided. As condensation is an objective physical phenomenon, the way to avoid condensation is usually from two aspects:

1) The water temperature of the water cooler should be set higher than the condensation temperature, but it needs to conform to cooling requirements. Therefore, in the corresponding environment, the water temperature setting can only select the blue area temperature in the dew point comparison table, so this method has limitations.

2) By decreasing the temperature and humidity of laser working environment, it can expand setting range of water cooling temperature to make the water temperature lower than the dew temperature.

2.6 Attentions

- 1) Make sure that grounding is safe and firm before using the laser.
- 2) Make sure that the correct voltage (220VAC) is used before connecting AC current. Failure to connect power supply will damage the device.
- 3) It is forbidden to touch laser processing head during operation.
- 4) It is forbidden to view the output head directly; and make sure that laser protective goggles are worn when operating the device.
- 5) Please cap the output head when it is not in use. Do not touch the output lens at any time. Use appropriate lens paper and alcohol to clean it if necessary.

- 6) High temperature in summer is easy to make laser condensate, which causes permanent damage to laser. Please make sure when laser is powered off, water chiller is also powered off.
- 7) Low temperature in winter is easy to make laser inside freeze, which causes permanent damage to laser. Please make sure when laser is powered off, water chiller is powered on.
- 8) Failure to operate the laser in accordance with the control or adjustment methods specified in this manual may cause damage.

2.7 Performance

Table 5 Product Parameters

| Model | RFL-B500D |
|-------------------------------------|--------------|
| Optical Characteristics | |
| Output Power(W) | 500 |
| Operation Mode | CW/Modulated |
| Polarization State | Random |
| Power Range(%) | 10~100 |
| Central Wavelength (nm) | 430-470 |
| Output Power Instability (%) | <3 |
| Modulation Frequency(Hz) | 50~10k |
| Red Laser Output Power(mW) | 0.25~1 |
| Output Cable Characteristics | |
| Output Head Model | iHQB |

| | |
|--|--|
| Core Fiber(μm) | 400 |
| Min Winding Diameter(mm) | ≥ 300 |
| Beam Divergence Half-angle(rad) | ≤ 0.22 |
| Delivery Cable (m) | 5 (can be customized) |
| Electrical Characteristics | |
| Power Supply | Single phase 220 \pm 10% V AC、50/60Hz (AC) |
| Control Mode | RS-232/AD |
| Other Characteristics | |
| Dimensions(W \times H \times D) (mm) | 447 \times 238 \times 850 |
| Weight(kg) | <60 |
| Operating Ambient Temperature ($^{\circ}\text{C}$) | 10~40 |
| Humidity(%) | <70 |
| Storage Temperature($^{\circ}\text{C}$) | -10~60 |
| Cooling Method | Water Cooling |

3 Installation

3.1 Overall Dimensions

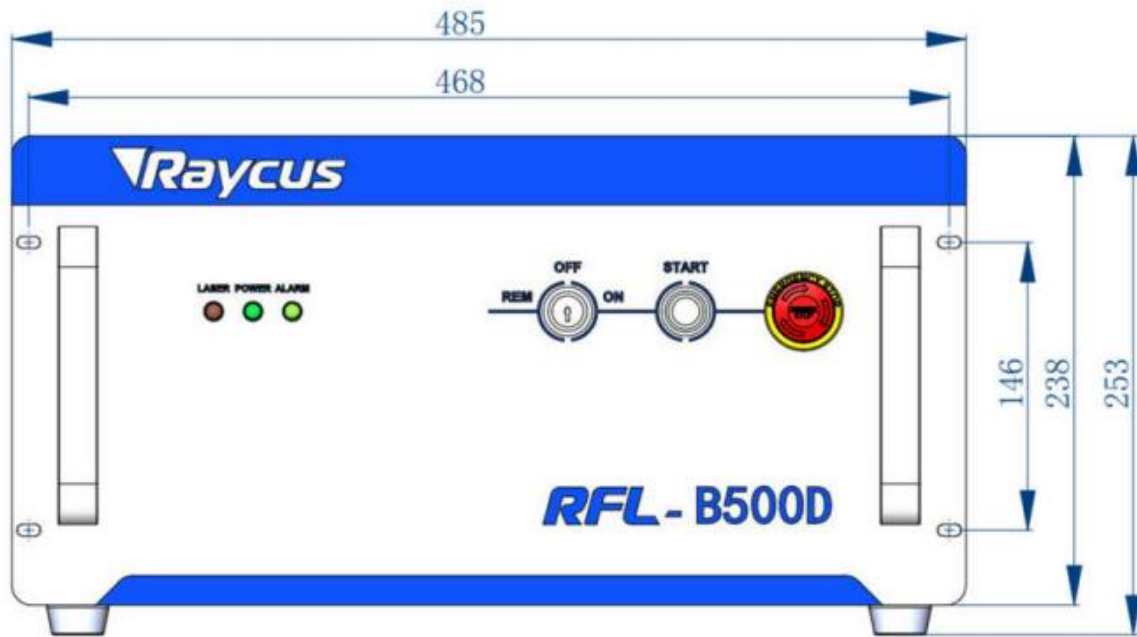

Figure 2 shows the external dimensions and installation size.

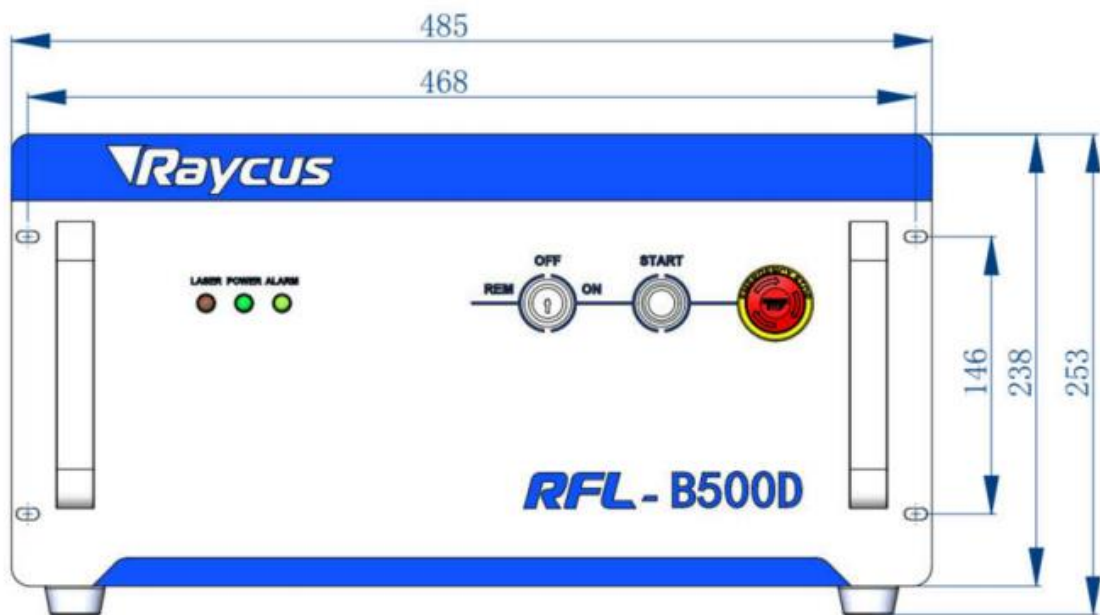



Figure 2 Front view (Unit: mm)

| | |
|---|--|
|  | <ul style="list-style-type: none"> ◆ Before installing the output cable in the processing head, the lens of the output cable must be inspected. If the lens is dirty, it must be cleaned. ◆ When installing output head into welding head, the slot of welding head short circuiting two copper rings of output head must be promised, otherwise alarm will start. ◆ It is forbidden to disassemble protective lens of output head by any party other than Raycus personnel, otherwise the warranty is invalid. |
|---|--|

3.3 Cooling System Installation and Requirements

Table 6 Cooling System Requirements

| Parameters | Unit | RFL-D500D |
|--------------------------------|-------|--|
| Cooling Capability (W) | W | ≥3000 (1.2) |
| Minimum Flow (L/min) | L/min | 8 |
| Maximum Input Pressure (Bar) | Bar | 7 |
| Water Pipe Joint Type and Size | mm | Straight quick plug joint (external diameter 12φ, PU water pipe) |
| Chiller Type | / | Double temperature and control |

1) Temperature setting of cooling water:

- In summer (ambient temperature is more than 30 °C)25±0.5 °C (ambient temperature is lower than 30 °C) 22±0.5 °C.

2) Requirements of Cooling Water:

- Purified water should be used and drinking purified water can be used.
- In order to prevent the growth of mold that may lead to blockage, adding no less than 10% ethanol of the total volume to purified water is recommended.

3) Other cooling system requirements:

- Check the entire water system and joints for leaks when starting the cooling system the first time. The external water pipe must be installed and connected

according to the water inlet (IN) and water outlet (OUT) marked by the laser, otherwise the laser may not work properly.

- If the laser is not used for a long time, the cooling system and the cooling water inside the laser should be drained, otherwise it will cause irrecoverable damage to the laser.
- When drain the cooling water in the water cooling system, please use less than 0.5Mpa compressed gas, otherwise it will cause irreversible damage to water cooling system.





| | |
|---|--|
|  | ◆ Set the water temperature of the cooling system correctly according to the ambient temperature. If the water temperature is set too high, the laser will not work properly. If the water temperature is set too low, condensation will occur inside the laser or the laser output cable, which will cause irrecoverable damage to the laser. |
|---|--|

| | |
|---|--|
|  | ◆ Before starting the laser, the cooling system must work properly and the water temperature reaches a suitable temperature.(summer: $25 \pm 0.5^{\circ}\text{C}$; winter: $22 \pm 0.5^{\circ}\text{C}$) |
|---|--|

3.4 Installation Precautions

- 1) Place the product in an appropriate position, immobilize it if necessary.
- 2) Before the laser is powered on, please inspect whether correct voltage of AC supply power is used($220\text{VAC} \pm 10\%$, 50/60Hz)
- 3) Connect the power cable and control cable to the product when power supply is OFF.
- 4) Connect the cooling system to the laser and output fiber cables according to the water inlet and outlet signs.
- 5) Please check the laser output head and do the necessary cleaning before installing it in the device.
- 6) Prevent the delivery cable from treading, pinching or excessive bending during installation in order to avoid damages.

- 7) Make sure the ambient environment is clean, or the output head may be contaminated. It is prohibited to use fans during installation, which will cause dust in the air.

| | |
|---|--|
|  | <ul style="list-style-type: none">◆ CAUTION: All the cables can only be connected when power supply is off. Hot plug may damage the device. |
|  | <ul style="list-style-type: none">◆ Ensure that output cable is placed in a natural state. Avoid its excessive twisting and tight bends.◆ Tight bends will damage the laser delivery system. |
|  | <ul style="list-style-type: none">◆ During the process of installation and disassembling, please handle the output head gently in case of vibration and collision. |
|  | <ul style="list-style-type: none">◆ Before assembling the laser output head, the optical lens and the processing head cavity must be clean and pollution-free.◆ Please take good care of the protective cap of the output head to prevent it from being polluted. Otherwise, it will cause indirect pollution to the output head when the protective cap is covered |

4 Using the Product

| | |
|---|---|
|  | ◆ From January, 2019, Model S1901Lxxx has already stop using super terminal, and super terminal can not be displayed when laser is powered on. Please log on Raycus official website to download the upper computer software (Version 3.4)and manual. |
|---|---|

4.1 Front and Rear Panel

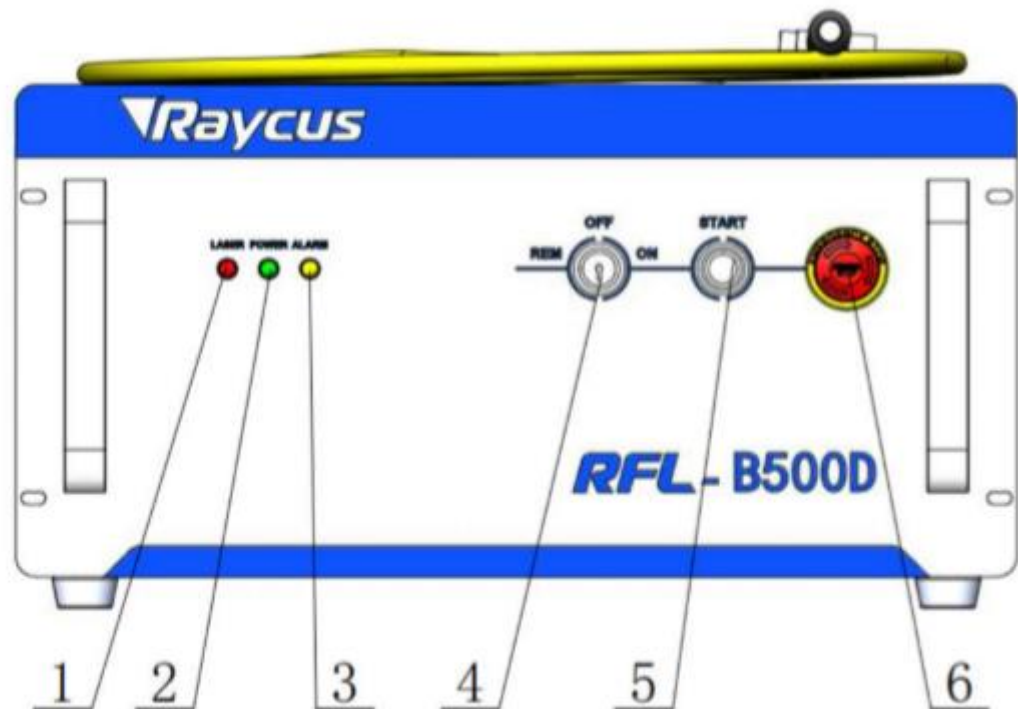

Figure 5 front panel

Figure 5 shows the front panel model.

- 1) **LASER**: red laser indicator, when red light is on, it indicates that the laser receives light output enable signal and red light indicator is turned off; when red light is off, it indicates that the laser does not receive light output enable signal and red light indicator is turned on.
- 2) **POWER**: green power indicator, when green light is on, the power is turned on.
- 3) **ALARM**: yellow alarm indicator, when yellow light is on, the laser has faults.

- 4) REM/OFF/ON: key switch and power switch. Insert the key and turn to “ON” button or “REM” to turn on the laser. The laser will enter corresponding control mode according to preset “CTRL-INTERFACE” and follow-up operation.
- 5) START: light output enable button, red light indication. Press the button and the laser is waiting for light output at the same time when red light is turned off; press the button again to make it pop up and the laser turns off light output enable and red light is turned on.
- 6) EMERGENCY STOP: press to turn off the laser immediately and lock it. Rotate clockwise to release button. To return to normal working condition, users must repower it by key switch.

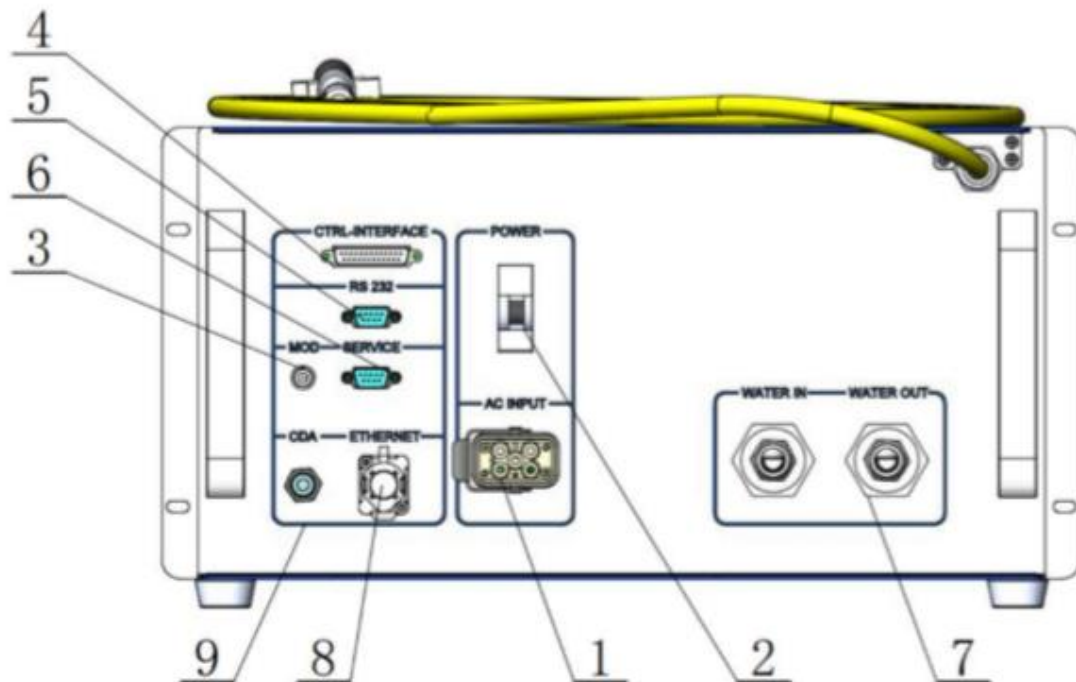

Figure 6 laser rear panel

Figure 6 shows the rear panel of the laser

1. **AC INPUT:** the socket for mains in. The socket must connect with the corresponding input voltage according to laser model (referring to product parameters in table 5) and be used with plug provided by Raycus.
2. **Power:** air switch, it can control AC on and off.

3. **MOD:** modulation signal input, used for controlling laser on and off in external control mode. The control signal needs more than 20mA driving force and 24V voltage.
4. **CTRL-INTERFACE:** control interface, as well as the alarm signal output interface, DB25 plug, GPIO. Users can set the control mode and input analog voltage signal.
5. **RS232:** 232 serial port, providing remote control and alarm information storage for the laser. Raycus provides matched RS-232 serial port communication cord.
6. **SERVICE:** provide part external interface function (referring to 4.3 interface definition)
7. **WATER:** water pipe connector, the water inlet and the water outlet are respectively connected with the inflow and outflow of the cooling water. The connector connects PU pipe with corresponding outer diameter size (referring to table 6)
8. **ETHERNET:** Ethernet interface for providing remote control and alarm information storage of the laser.
9. **CDA:** dry compressed air interface. When inner humidity is too high, dry compressed air is provided.

4.2 Power Connection



◆ Before connecting the AC power supply, please check whether the AC power supply and product power supply are consistent.

One end of the power cord is inserted into the laser socket through “AC INPUT”. Pay attention that the plug is wrong-side preventing. After inserting it, lock it with the lever. The other end of 500W laser is three stripped strands, on which respectively marks L, N, PE. They can be connected with 220VAC power according to labels.

Table 7 Power Wiring Description

| Label | Definition |
|-------|-----------------------|
| L | Phase line |
| N | Neutral line |
| PE | Protective earth line |

4.3 Interface Definition

4.3.1 Service Safety Interface

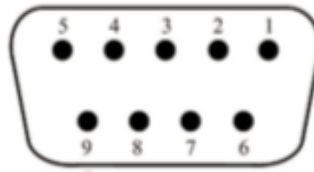

Figure 7 SERVICE safety interface

The pin definitions are as follows:

Table 8 SERVICE interface definition

| PIN | NAME | Function | Notes |
|-------|-------------|--|--|
| 1 | Power A | Remote switch, contact without power, cannot connect external voltage and ground | Short circuit pin1 and pin 2 to power on the laser. |
| 2 | Power B | | |
| 6 | INTERLO CK+ | Contact without power, cannot connect external voltage and ground | Short circuit pin1 and pin 2 before the laser is emitting. |
| 7 | INTERLO CK- | | |
| Other | NC | NO connection | / |



◆ Interlock can not be connected with power, otherwise it will cause damage to interface and laser, because the laser has short circuited with interlock before leaving the factory.

4.3.2 MOD Modulation Signal Interface

24V modulation signal should connect with interface as shown in Figure 8

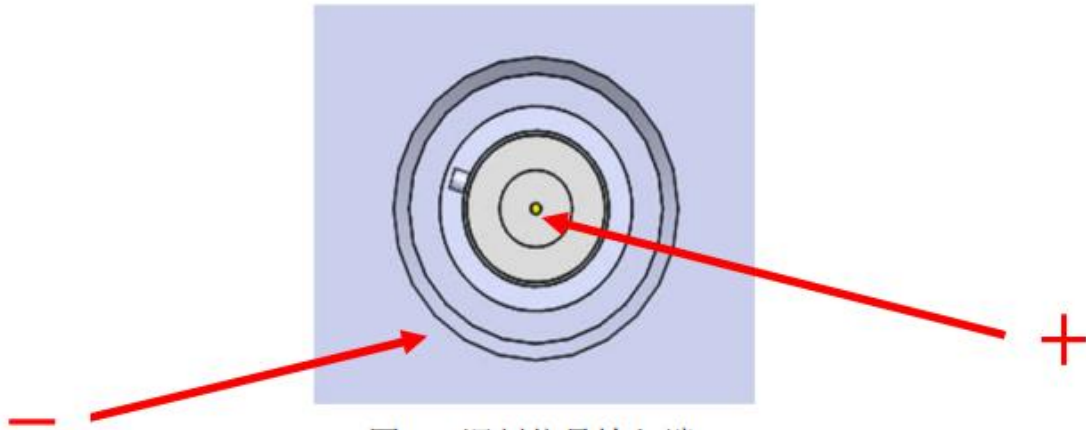

Figure 8 modulation signal input port

We provide modulation signal cable, as shown in Figure 9



18

Figure 9 modulation signal cable

| | |
|--|--|
| | <ul style="list-style-type: none"> ◆ Modulation signal cable core is “+24V” and external metal mesh is “GND” ◆ Please check whether level conforms to product requirements before modulation signal connects with the laser. |
|--|--|

Descriptions of modulation signal interface is shown in Table 9.

Figure 9 MOD signal introductions

| Name | Input/output | Function | Level | Current |
|------|--------------|----------------------------|-------|---------|
| MOD | input | external modulation signal | 24V | 10mA+ |

Inner circuit of modulation signal is shown in Figure 10

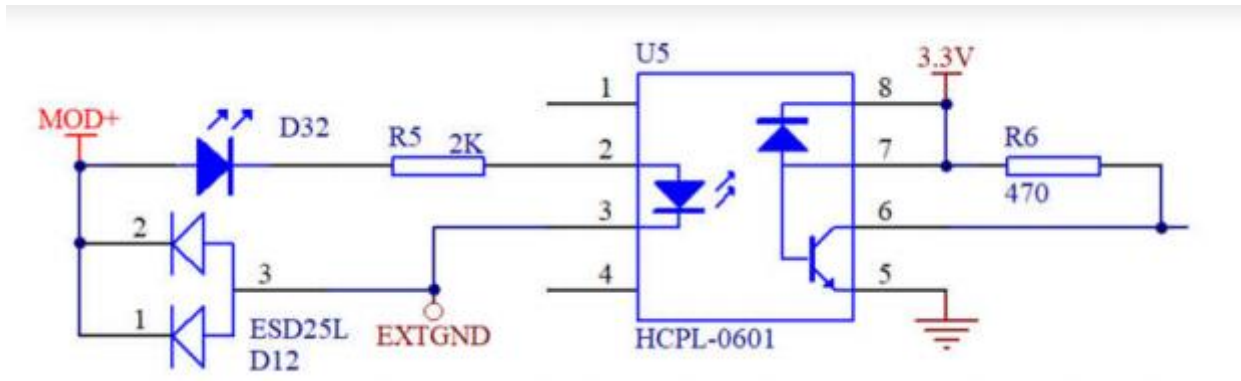

Figure 10 Inner circuit

4.3.3 CTRL-INTERFACE

Figure 11 shows the diagram of DB25 control interface; Figure 10 shows pin definition of DB25.

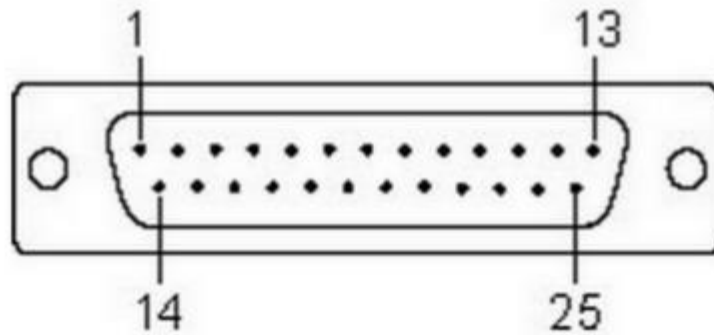

Figure11 DB25 control interface

Table 10 Definition

| PIN Number | Name | Function | | Voltage | Current | |
|------------|----------|----------|------------------------------|-----------|---------|------|
| 6 | LASER_EN | input | Laser emission signal enable | enable | 24V | >8mA |
| | | | | forbidden | 0V | / |
| 7 | AD_EN | input | External AD mode selection | enable | 24V | >8mA |
| | | | | forbidden | 0V | / |

| | | | | | | |
|--------|-------------|--------|---|--------|---------|--------|
| 8 | Laser Ready | output | Laser Ready | YES | 24V | <100mA |
| | | | | NO | 0V | / |
| 9 | EX_GND | / | 6、7、8、20、24 reference | / | 0V | / |
| 20 | EX_VCC | input | Supply power for PIN8 and PIN24 | / | 24V | <500mA |
| 22 | Analog | input | Given analog quantity of external power | / | 0V~10V | >10mA |
| 23 | Laser Power | output | Corresponding voltage | / | 0V~3.8V | <10mA |
| 24 | Alarm | output | Fault signal | fault | 24V | <100mA |
| | | | | normal | 0V | / |
| 25 | AGND | / | 22、23 reference | 0V | | / |
| Others | NC | / | No connection | / | | / |



- ◆ Please check whether the level of control signal conforms to requirements. Exceeding or fluctuating voltage can destroy lasers.
- ◆ Please make sure that simulation voltage signal does not exceed 10V, or it can destroy lasers.

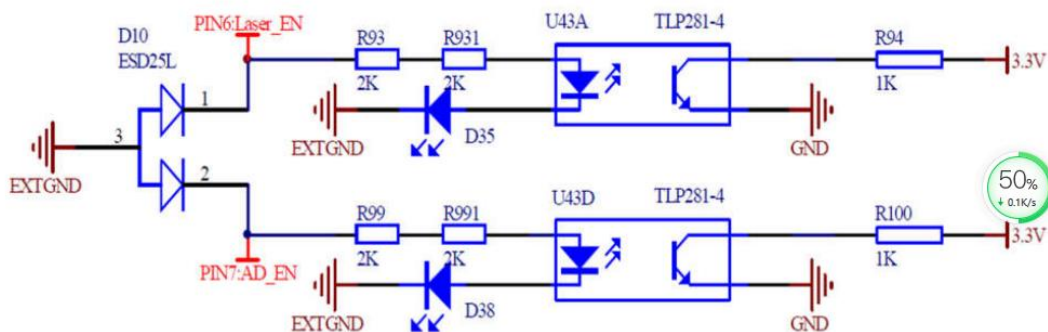

Figure 12 Pin6、7 inner circuit diagram

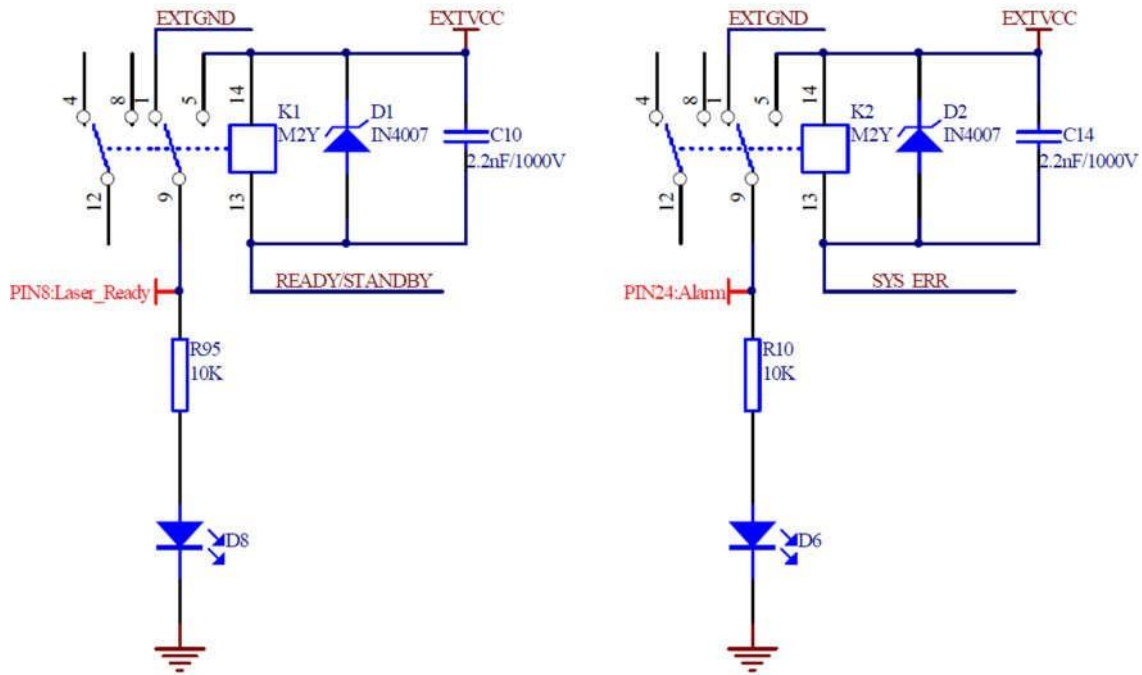

Figure 13 Pin8、24 inner circuit diagram

4.3.4 RS-232 Serial Port

The following figure shows the RS-232 serial port

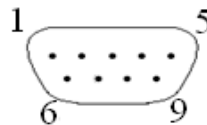

Figure 14 RS232 serial port

Each pin is defined as follows.

Table 11 RS-232 serial port definition

| Model | Definition |
|--------|------------|
| 2 | RX |
| 3 | TX |
| 5 | GND |
| Others | NC |

4.3.5 Ethernet TCP / IP Interface and Connection Steps

The default IP address of the laser is 192.168.0.10 and the laser only supports UDP communication. The communication port of the laser is 8099. The command must be sent as a single string in a single packet.

Table 12 Ethernet interface pin definition

| PIN | Feature | Description |
|-----|---------|----------------|
| 1 | TX+ | Transmit Data+ |
| 2 | TX- | Transmit Data- |
| 3 | RX+ | Receive Data+ |
| 4 | N/C | Not Connected |
| 5 | N/C | Not Connected |
| 6 | RX- | Receive Data - |
| 7 | N/C | Not Connected |
| 8 | N/C | Not Connected |

If conditions permit, please use this interface first to get better communication stability.

Ethernet connection steps:

First Step: Open Raycus PC software, click "Session → RS232(or Ethernet)" to make the host computer communicate with the laser, and then click "Tool → Laser IP Set" to enter the laser IP address setting;

Second Step: The default password is "1122334455667788". After passing the verification, read or set a new laser IP address.

Third Step: If you use the upper computer software of Raycus to control the laser, you need to find the folder where the upper computer software is located, open the laser configuration file config.xml, and write the newly set IP address of the laser; if you do not use the upper computer of Raycus, please directly enter the fourth step;

Fourth Step: Configure the Ethernet network connection on the PC side, select "Use the following IP address:", and manually assign the IP address. The PC side IP address must be on the same network segment as the laser IP address, and assign a subnet mask address. The default is 255.255.255.0. Click the "OK" button to confirm the settings and exit.

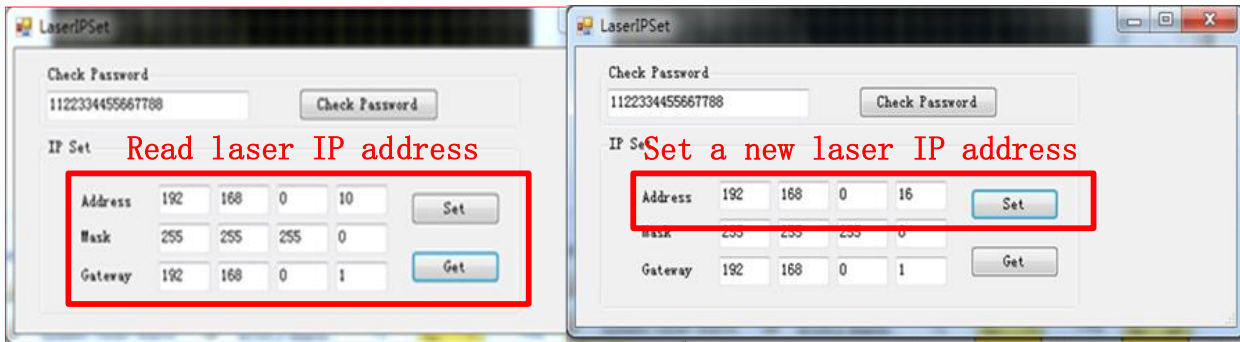

Skip this step if you do not control the laser with a Raycus host computer

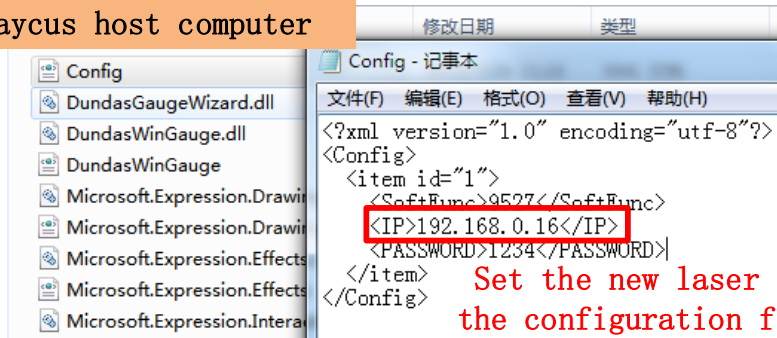

Set the new laser IP address in the configuration file config.xml

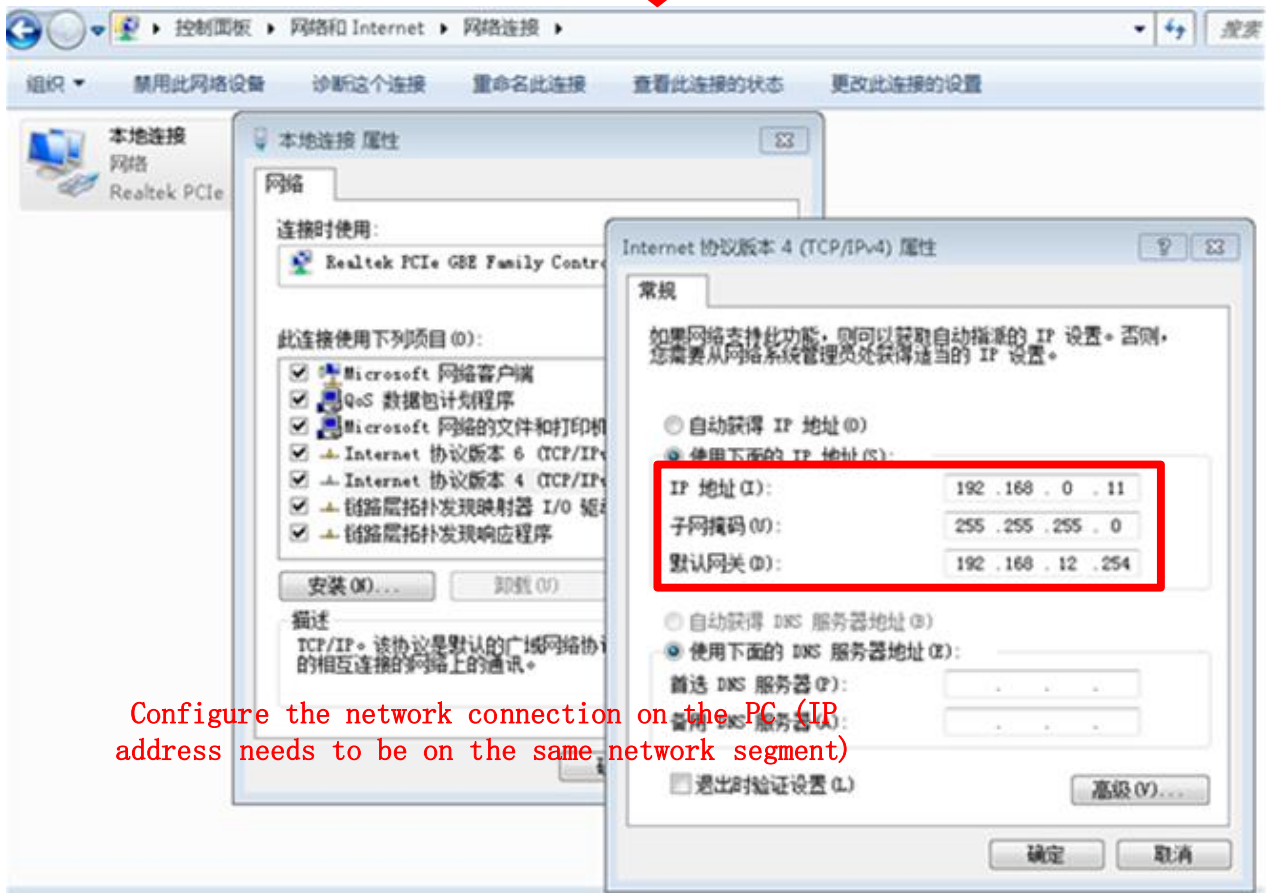

Configure the network connection on the PC (IP address needs to be on the same network segment)

Figure 10 Ethernet connection steps

4.4 Laser Working and Control Mode

The laser has two working modes: continuous and modulation mode. In continuous mode, the output power of laser can be controlled by setting power percentage or analog quantity. In the modulation mode, the output of the laser is pulse laser, and the optical waveform is set by setting the frequency, duty cycle and power percentage.

There are three control modes to choose from: external RS232 control mode, external AD control mode and internal control mode. The external RS232 control mode is to set parameters internally and control light output externally; External AD control mode is to provide external light output conditions (MOD, analog quantity, etc.) and external control light output; The internal control mode is to set parameters and control the light output internally. At the same time, each control mode of the laser can realize two control modes: continuous mode and modulation mode.

4.5 Start Operation Sequence

All electrical connections must be completed before the laser is powered on.

- a) Make sure that Pin6 and pin7 of SERVICE interface has been closed;
- b) Open the water chiller to check whether waterway is normal or not;
- c) Turn on the AC power;
- d) Please short circuit Pin1 and Pin2 of SERVICE interface and start the laser.

4.6 Control Mode Selection

The laser provides the supporting upper computer software (please visit the official website of Raycus to download the upper computer software and software instructions).

The introduction of functional area is shown in Figure 16.

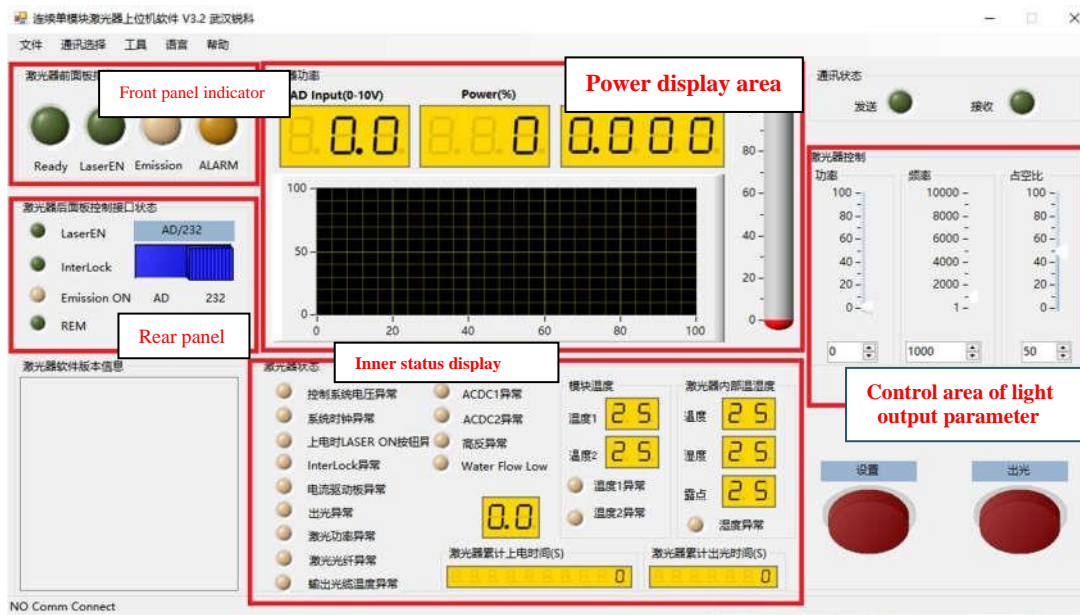

Figure 16 Functional area introductions

Table 13 Functional area descriptions

| Functional area | Descriptions |
|-----------------------------|-----------------------------------|
| Laser front panel indicator | Ready——laser ready |
| | Laser EN——laser enable |
| | Emission——laser is emitting light |

| | |
|---|--|
| | Alarm——laser triggers alarm |
| Rear panel control interface status | Laser EN——Control Interface in which LASER ON pin is high level |
| | Interlock——Control Interface in which InterLock is closed |
| | Emission ON——laser is emitting light |
| | REM——laser is in external control mode |
| | AD——The laser operates in external AD control mode, and the laser power is controlled by external 0-10V |
| | 232——The laser operates in external RS232 control mode, and the laser power is set by software |
| Laser power display | Display the set laser power percentage or analog quantity |
| Laser inner status display | The internal state of the laser is displayed. If the indicator light is on, there will be fault or abnormality |
| Control area of light output parameters | Set the parameters of laser power, frequency and duty cycle |
| | “Set” button——After setting the parameters, you need to click the "set" button to issue the command |
| | “Emission” button——Press the button first and the laser will emit light. Then the button will pop up; at last, turn off the laser and it will emit light |

4.6.1 External RS232 Control Mode Wiring Diagram

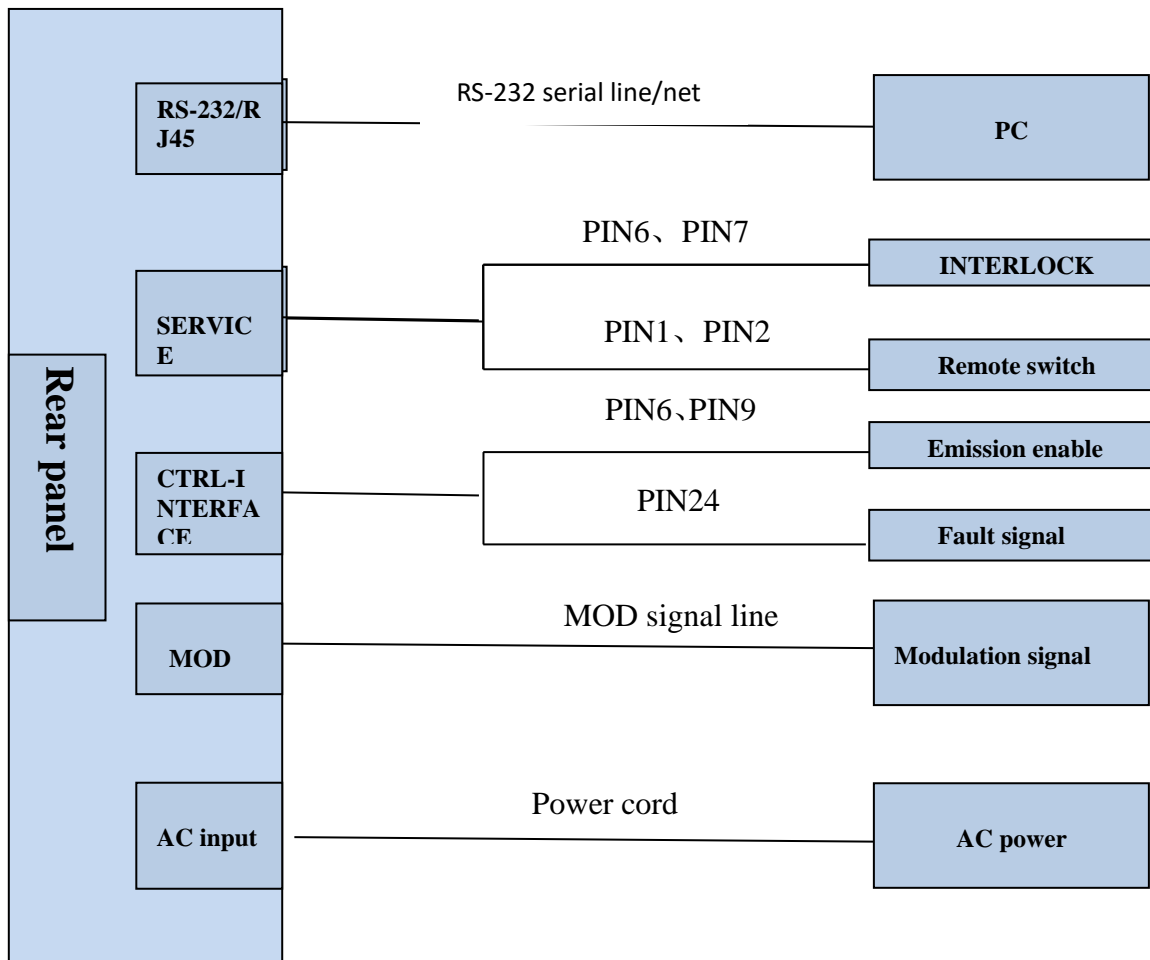

Figure17 External RS232 control mode wiring diagram

4.6.2 External Control Mode Operation Process

- a) Short circuit the pin17 and pin18 of DB25 control interface to select the external control mode;
- b) Please ensure that pin7 and pin9 of DB25 control interface are disconnected to make the laser enter the external control mode before the laser is powered on;
- c) Turn on the AC power and the "power" indicator on the front panel of the laser will be on;
- d) The circuit initialization of internal control panel is completed after waiting for 10s;

- e) The laser power is set in the upper computer software;
- f) The external MOD interface provides the "modulation" signal for the laser;
- g) The laser is given an emission enable signal by one of the following ways:
 - The connection between the pin6 and pin9 of DB25 control interface is 24 V - emission enable
 - The upper computer software sends out light command – emission enable.
 - The pin15 and pin16 of DB25 control interface are short circuited –emission enable

4.6.3 External Control RS232 Time Sequence Diagram

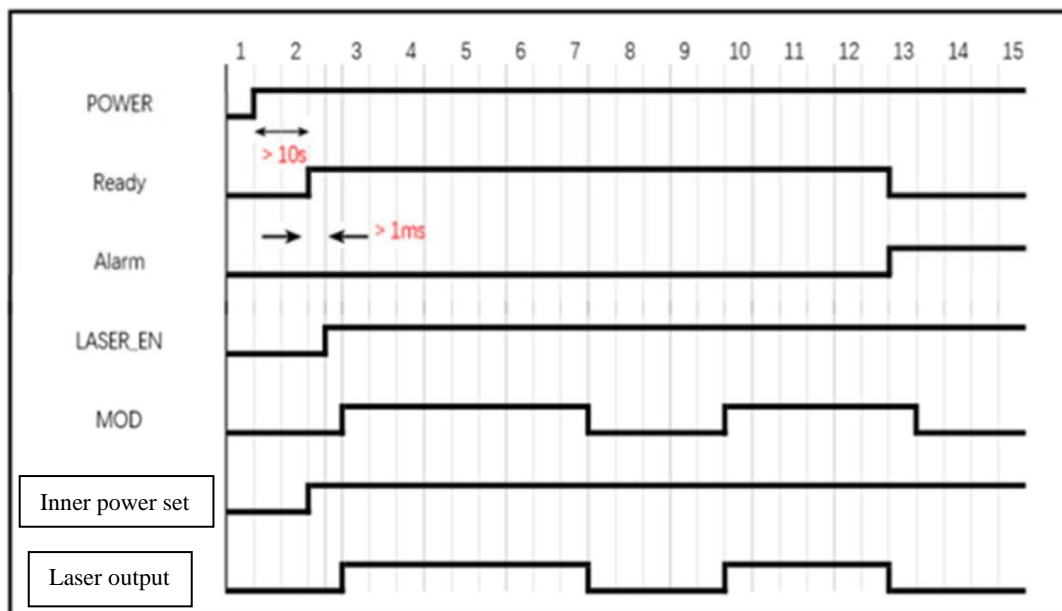

Figure 18 Continuous mode – time sequence diagram

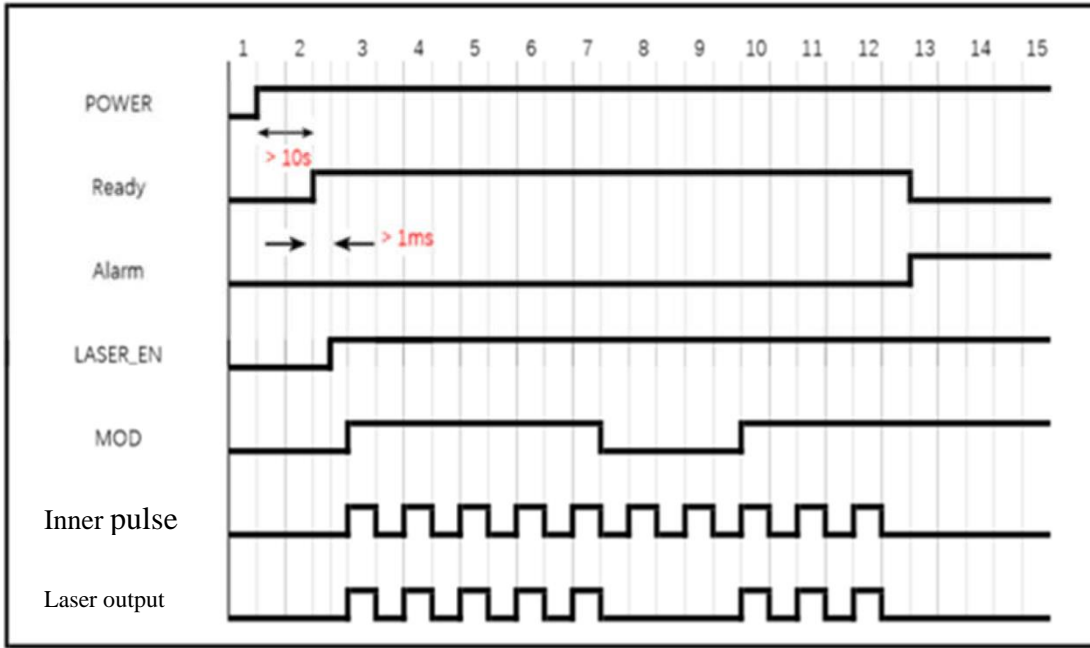

Figure 19 Modulation mode—time sequence diagram

4.6.4 External Control AD Wiring Diagram

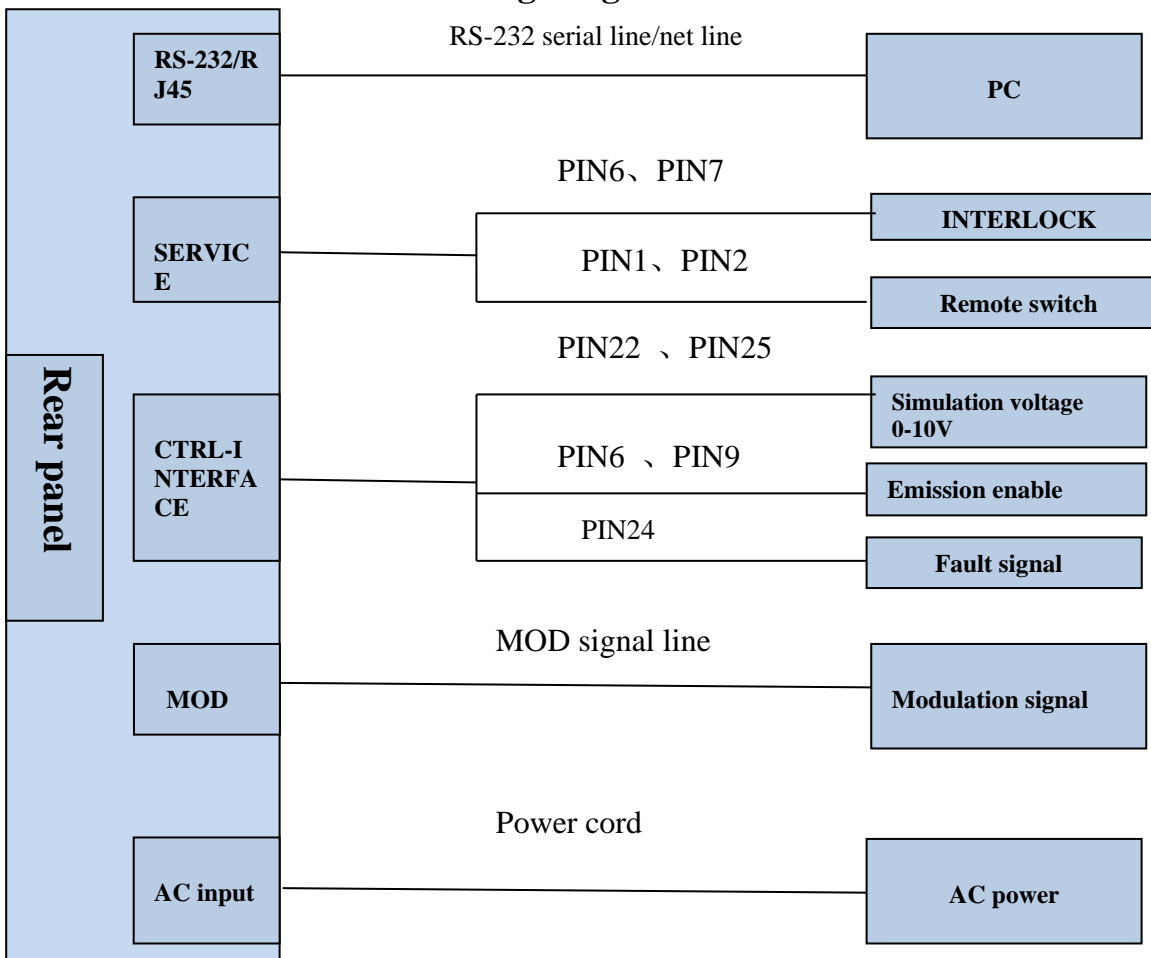

Figure20 External AD control mode wiring diagram

4.6.5 External Control AD Operation Process

- a) Short circuit the pin17 and pin18 of DB25 control interface to select the external control mode;
- b) Please ensure that 24V is connected between pin7 and pin9 of DB25 control interface before the laser is powered on to make the laser enter the AD control mode;
- c) Turn on the AC power and the "power" indicator on the front panel of the laser will be on;
- d) The circuit initialization of internal control panel is completed after waiting for 10s;
- e) The laser output power is controlled by voltage between PIN22 and PIN25;
- f) The external MOD interface provides the "modulation" signal for the laser;
- g) The laser is given an emission enable signal by one of the following ways:
 - The connection between the pin6 and pin9 of DB25 control interface is 24 V - emission enable.
 - The upper computer software sends out light command – emission enable.
 - The pin15 and pin16 of DB25 control interface are short circuited –emission enable

4.6.6 External Control AD Time Sequence Diagram

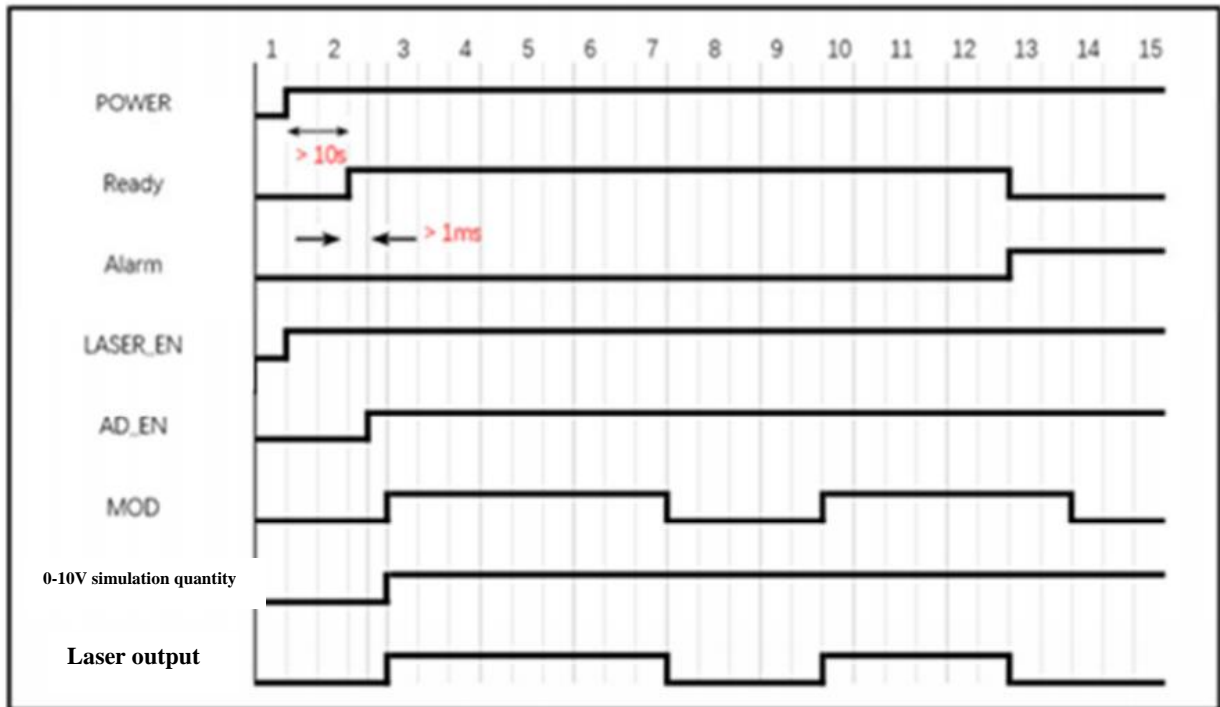

Figure 21 External AD control mode time sequence diagram

4.6.7 Inner Control Mode Wiring Diagram

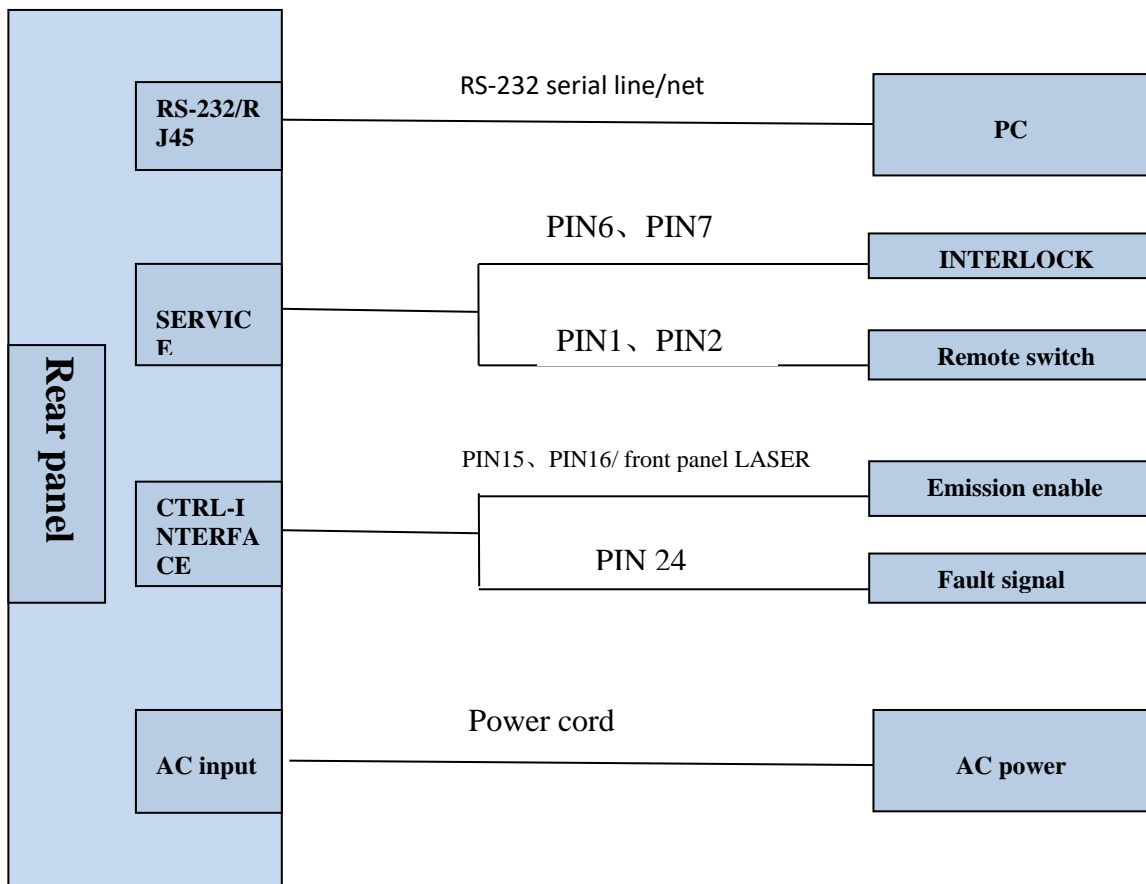

Figure22 Laser inner control mode wiring diagram

4.6.8 External Control AD Operation Process

- a) The pin17 and pin18 of DB25 control interface is disconnected to select the inner control mode;
- b) Turn on the AC power and the "power" indicator on the front panel of the laser will be on;
- c) The circuit initialization of internal control panel is completed after waiting for 10s;
- d) Laser power is set in upper computer software and issue an emission command;
- e) PIN15 and PIN16 of DB25 control interface is short circuited to carry out emission enable.

4.6.9 Inner Control Mode Time Sequence Diagram

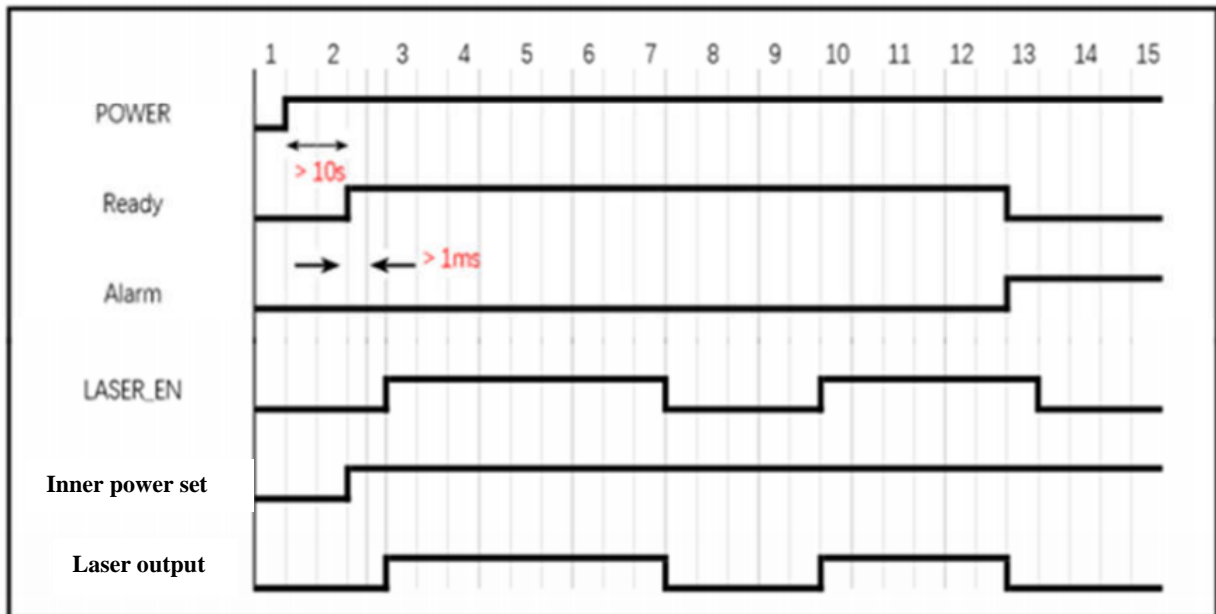

Figure23 Continuous mode- time sequence diagram

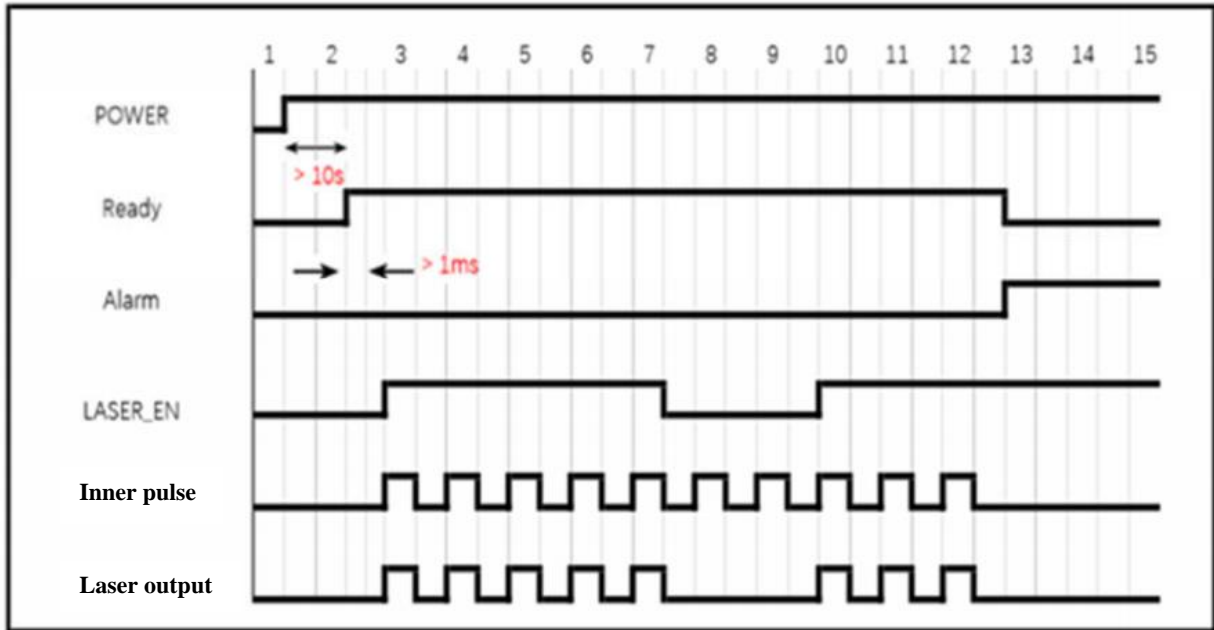

Figure24 Modulation mode-time sequence diagram

4.7 Red Light Control

When the power is connected, “power” green indicator will be on, and red indication light will be output; when the laser emits, red indication light will be turned off; when laser enable is turned off, red indication light will be output.



- ◆ Laser and red indication light cannot be output at the same time. If red light is not output in your using process, please check whether to turn off enable signal.

4.8 Shut-down Operation Sequence

Please turn off the laser according to correct sequence:

- a) Turn off emission enable;
- b) Disconnect the laser power supply;
- c) Turn off the cooling system.

5 Common Alarms and Solutions

5.1 Alarm Display

Connect the computer and open the PC software (download the PC software and its instruction manual, please log on the Raycus official website), after the laser and client software establish normal communication. All laser alarm states can be displayed on the client software interface, as shown in Figure 17. The laser will give an alarm in the case of abnormal internal temperature, abnormal output power, abnormal power supply, abnormal condensation, etc.

When the laser is working, any alarm occurs (except for the abnormal interlock), the upper computer software interface will also display the alarm. At the same time, the alarm light (yellow) on the laser panel will be on, and the laser will stop and lock. After troubleshooting, the laser must be abnormal reset to reset light output

When the laser is abnormal, “Ready” signal output by laser is low level. Meanwhile, the software interface will display abnormal Interlock, but the laser does not lock and yellow alarm light is not on. When Interlock is normal, the laser will be immediately restoring normal light output. “Ready” signal returns to high level.

5.2 Alarm Processing

The instructions and possible solutions of alarms are as follows:

Table14 Error instructions and possible solutions

| Alarm message | Error instructions and possible solutions |
|-----------------------|--|
| System Timer Alarm | <p>Instruction: Internal clock abnormal</p> <p>Solutions: When this alarm occurs, please contact Raycus directly</p> |
| Laser On Button Alarm | <p>Instruction: This alarm occurs when the PIN 15 and PIN16 of laser CTRL-INTERFACE interface has been short circuited before powering on</p> |

| | |
|----------------------|---|
| | <p>Solutions: When this alarm occurs, please power off the laser and make the PIN 15 and PIN16 of laser CTRL-INTERFACE interface disconnected, and then power on the laser again to cancel the alarm. If the alarm continues to occur, please contact Raycus.</p> |
| Inter Lock Alarm | <p>Instruction: It occurs when the laser InterLock is disconnected</p> <p>Solutions: Short the InterLock pins. If this error continues to occur, please contact Raycus.</p> |
| Current Driver Alarm | <p>Instruction: It occurs when internal constant current driver is abnormal</p> <p>Solutions: Restart the Device. If this error continues to occur, please contact Raycus.</p> |
| Laser Power Alarm | <p>Instruction: The alarm is generated when the output power of the laser cannot reach the set value. Power alarm occurs only when the laser is emitting light.</p> <p>Solutions: Restart the Device. If this error continues to occur, please contact Raycus.</p> |
| ACDC1 Alarm | <p>Instruction: AC/DC1 Alarm. Laser power supply out of work or sudden power disconnect of the power supply systems may cause the alarm</p> <p>Solutions: Check whether the input AC voltage is normal. Restart the laser to try when it is normal. If the alarm continues to occur, please contact Raycus.</p> |

| | |
|---------------------------|--|
| <p>T1/T2/T3 /T4 Alarm</p> | <p>Instruction: Laser low / high temperature alarm occurs when the sensor in the laser detects that the internal temperature of the laser is abnormal. A high-temperature / low-temperature error occurs when the temperature at the monitoring point exceeds the set upper / lower limit.</p> <p>Solutions: When high temperature alarm occurs, please check whether the water-cooling system is normally working, the water temperature is set correctly, and if the water connection is set correctly. When the water cooling system works normally and the water temperature drops below 30°C, restart the laser. If the alarm continues, please contact Raycus.</p> <p>When low temperature alarm occurs please check whether the actual water temperature of the water is too low. In addition, a low ambient temperature may also cause a low temperature alarm when the laser is cold. Please wait until the water temperature of the water rises above 10°C and then restart the device. If the alarm continues, please contact Raycus.</p> |
| <p>Hum Alarm</p> | <p>Instruction: The laser detects that the current temperature of the water-cooled plate is lower than the current dew point temperature of the laser. There is a risk of condensation.</p> <p>Solutions: Stop using the laser immediately. When condition reaches the normal status, restart the laser to try. If the alarm continues, please contact Raycus.</p> |

In addition to the above, if there are any other questions or errors, please contact Raycus.

6 Warranty, Return and Maintenance

6.1 General Warranty

After all the products manufactured are delivered according to the order or specifications, Raycus will guarantee the products with material and technical problems and ensure that they meet the specifications under normal use.

Raycus has the right to selectively repair or replace any products with material or technical problems during the warranty period. All products repaired or replaced during the warranty period are guaranteed free warranty only for those products with special problems. Raycus reserves the right to charge the payment for the products with problems under normal use.

6.2 Limitations of Warranty

The warranty does not cover the maintenance or reimbursement of our product of which the problem results from tampering, disassembling, misuse, accident, modification, unsuitable physical or operating environment, improper maintenance, damages due to excessive use or not following the instructions caused by those who are not from Raycus. The customer has the responsibility to understand and follow this instruction to use the device. Any damage caused by fault operating is not warranted.

Power cord, RS-232 serial port line, modulation signal line, other spare parts such as output cable and output head and so on are excluded from this warranty.

According to the warranty, client should write to us within 31 days after the defect is discovered. This warranty does not involve any other party, including specified buyer, end-user or customer and any parts, equipment or other products produced by other companies.



◆ **WARNING:** It is the customer's responsibility to understand and follow operating instructions in this User Guide and specifications prior to operation-failure to do so may void this warranty.

6.3 Service and Repair

- This product has no built-in parts for user maintenance, so all maintenance should be carried out by Raycus technical personnel.
- In case of any alarm during the use of the product, the technical personnel of Raycus shall be informed in time and troubleshooting shall be carried out.

- All repair or replacement products must be placed in the original packaging box provided by Raycus, otherwise any product damage caused by this will not be repaired free of charge by Raycus.
- When you receive Raycus products, please check whether the products are intact in time. If there is any abnormality, please contact the carrier or Raycus in time.

Raycus will continue to develop new products. The product information listed in the manual is subject to change without further notice. All technical parameters are subject to the contract terms.

The above product warranty and service terms of Raycus are for users' reference only, and the formal service and warranty contents are subject to agreement in the contract.