



# Continuous-Wave Fiber Laser

## User Guide

RFL-C3000S

Wuhan Raycus Fiber Laser Technologies Co., Ltd.



## TABLE OF CONTENTS

<b>1 Safety Information .....</b>	<b>5</b>
1.1 Symbols Used in this User Guide .....	5
1.2 Laser Classification .....	5
1.3 Safety Labels .....	6
1.4 Optical Safety .....	7
1.5 Electrical Safety .....	8
1.6 Other Safety Rules .....	8
<b>2 Product Description .....</b>	<b>9</b>
2.1 Features .....	9
2.2 Model Configuration .....	9
2.3 Package Contents .....	10
2.4 Unpacking and Inspection .....	10
2.5 Operation Environment .....	11
2.6 Precautions for Use .....	12
2.7 Specifications .....	13
<b>3 Installation .....</b>	<b>14</b>
3.1 Dimensions .....	14
3.2 Output Head and Installation .....	15
3.3 Cooling Requirements .....	16
3.4 Installation Procedure .....	18
<b>4 Using the Product .....</b>	<b>20</b>
4.1 Front Panel .....	20
4.2 Rear Panel .....	20
4.3 Power Connection .....	22
4.4 Interface Definitions .....	23
4.5 Steps of Installation .....	26
4.6 Steps of Starting .....	27
4.7 Control Modes .....	28
4.8 Steps of shutting down .....	34
<b>5 Alarms and Solutions .....</b>	<b>35</b>
5.1 Alarms Display .....	35
5.2 Alarm solutions .....	35
<b>6 Warranty, Return and Maintenance .....</b>	<b>39</b>
6.1 General Warranty .....	39
6.2 Limitations of Warranty .....	39
6.3 Service and Repair .....	39

## 1 Safety Information

Thank you for choosing Raycus fiber laser. This User Guide provides important safety, operation, warranty and other information. Please read it carefully before you use this product. In order to ensure safe operation and optimal performance of the product, please follow the warnings, cautions, operating procedures and other instructions accordingly.

### 1.1 Symbols Used in this User Guide

	<p><b>WARNING:</b> Refers to a potential hazard that may leads to a personal injury or death.</p>
	<p><b>CAUTION:</b> Refers to a potential hazard that may leads to a minor personal injury or product damage.</p>

### 1.2 Laser Classification

This series of lasers are classified as a high power Class 4 laser instrument according to the European Community standards EN 60825-1, clause 9. This product emits invisible laser radiation at or around a wavelength of 1080nm, and the total light power radiated from the optical output is greater than 1500W~2000W (depending on model). Direct or indirect exposure of this level of light intensity may cause damage to the eyes or skin. Despite the radiation being invisible, the beam may cause irreversible damage to the retina and/or cornea. Appropriate and approved laser safety eyewear must be worn all the time while the laser is operating.



**WARNING:** You must use appropriate laser safety eyewear when this device is operating. The laser safety eyewear is selected according to the range of wavelengths emitted from this product. The end user must ensure that the laser safety eyewear being used protects against light emitted by the device over its entire range of wavelengths. Please verify that the personal protective equipment (e.g. enclosures, viewing windows or viewport, eyewear, etc.) being utilized is adequate for the output power and wavelength ranges listed on the product.

### 1.3 Safety Labels

The position of the safety labels on products varies depending on the model of the continuous-wave fiber laser, as shown in Figure 1:

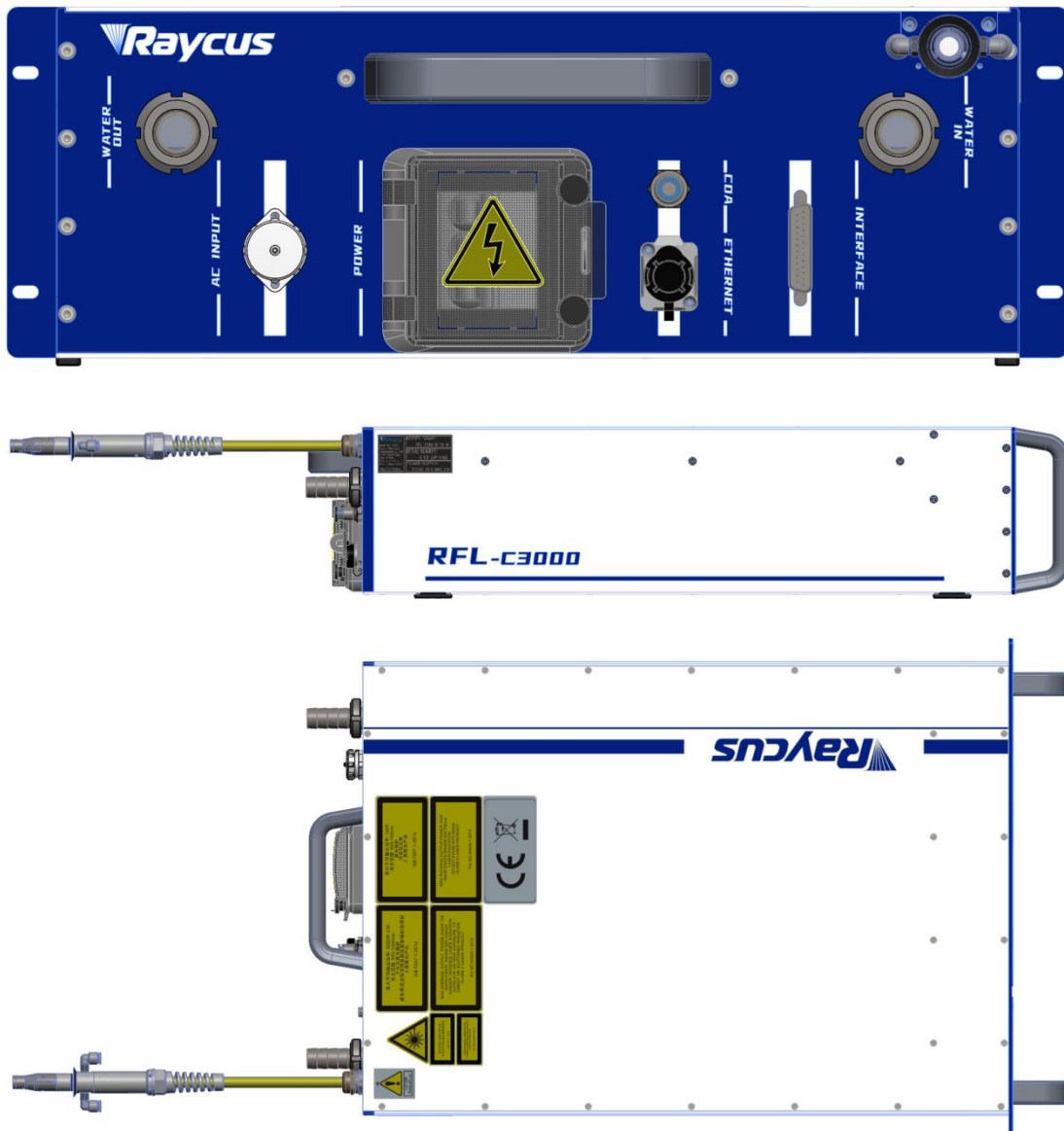

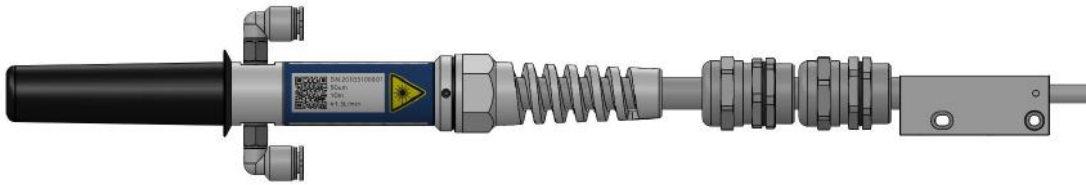

Figure 1: Safety Label Locations of RFL-C3000S

These safety labels include warning labels, apertures through which laser radiation is emitted and labels of certification and identification, etc. Specifications of these labels are as follows:

Table 1: Specifications of Safety Labels

	<p>(Take 500W for example)</p>	
<p>1.Aperture Label</p>	<p>2.Class 4 Laser Product</p>	<p>3.Class 2M Laser Product Label for Guide Laser</p>
<p>4. CE Compliance</p>	<p>5. Identification Plate</p>	<p>6.Laser Radiation Hazard Label</p>
<p>7.Electrical Hazard</p>		

## 1.4 Optical Safety

Any dust on the end of the collimator assembly can burn the lens and damage the laser.



**CAUTION:** If the output of the device is delivered through a lens with an anti-reflection coating, make sure that the lens is of good quality and clean.

## 1.5 Electrical Safety

- a) Make sure your product is grounded through the PE line of the AC power cord. The grounding must be firm and reliable.



**WARNING:** Any interruption from the protective earth will electrify the enclosure, which may result in personal injury.

- b) Make sure that the correct voltage of the AC power source is used.



**CAUTION:** Failure to connect the correct voltage could damage the product.

## 1.6 Other Safety Rules

- a) Never look directly into the laser output port when power is supplied to the laser.
- b) Avoid using the laser in a dim or darkened environment.
- c) If this device is used in a manner not specified in this document, the protection provided by the device may be impaired and the warranty will be voided.
- d) There are no operator serviceable parts inside, and all maintenance must be performed in Raycus or by qualified Raycus personnel. Do not try to remove covers, or electrical shock may be caused, and warranty will be void.

## 2 Product Description

### 2.1 Features

Compared with traditional lasers, Raycus CW fiber laser has higher efficiency electric-optical conversion, lower power consumption and excellent beam quality. The fiber laser is compact and ready to use. It can be used as a stand-alone unit or easily inserted into user's apparatus.

#### **Main Features:**

- Excellent beam quality
- High quality fiber output
- High Power Stability
- Continuously tunable output power, quick switching response
- Maintenance free operation
- High electron-optical efficiency
- Convenient control interface
- High frequency modulation

#### **Applications:**

- Cutting, Welding
- 3D Printing
- Scientific research

### 2.2 Model Configuration

The series of Raycus continuous-wave fiber laser include 1500W and 2000W, and the model designation codes are illustrated in the following table:

Table 2 Model Names and Designation Codes

<p style="text-align: center;"><u>RFL-C 3000S/B/20/W</u></p> <p style="text-align: center;"> <span style="margin-right: 100px;">①</span> <span style="margin-right: 100px;">②</span> <span style="margin-right: 20px;">③</span> <span style="margin-right: 20px;">④</span> <span>⑤</span> </p>	
1	RFL-C series, continuous-wave (CW) fiber laser
2	Power in watts: 3000S--3000W
3	Wavelength: B--1080nm
4	Length of delivery cable in meter, including 15m and 20m, and other length can be customized.
5	Cooling method: W-- water cooling A-- air cooling
<p><b>Note:</b> No air conditioner in this laser series except the RFL-C1500X/C2000X.</p>	

You can find the complete model name on the identification plate.

## 2.3 Package Contents

Please refer to the packing list accompanying the shipment to check actual items included.

## 2.4 Unpacking and Inspection

Raycus CW fiber laser is shipped in a package designed to provide maximum protection. Upon delivery, please inspect all packaging for evidence of mishandling or damage. If you find any evidence of mishandling, please save the damaged material and contact the shipping agent and Raycus immediately.

Remove all the contents from the packing case. Take extra care when removing the unit out of the packing case to ensure that the delivery fiber is not twisted, hauled or damaged. A comprehensive packing list is included with the system documentation. Check all items against the list and contact Raycus immediately if there is any missing item or evident damage to the unit. DO NOT attempt to install or operate the laser, if there is any evident or suspected damage to the unit.

It is recommended to keep the packing materials, as they will be necessary if you ever need to ship the unit back for service at a later date.

	<p><b>CAUTION:</b>The fiber optic cable and output head is precise optic instrument, any vibration or impact to the output head, and twist or excessive bend to the cable will damage the instrument.</p>
---	---

## 2.5 Operation Environment

The basic operation conditions are listed in the table as below:

Table 3 Basic Operation Conditions for the Laser

Model	C3000S
Supply Voltage(V)	380 ± 10% V AC 50/60Hz
Supply Capacity(kW)	10
Installation Requirements	Install on flat surface, no vibration or impact
Ambient Temperature(°C)	10~40
Relative Humidity(%)	30~70

### Warning:

- a) Ensure reliable grounded before using the laser.
- b) The laser output is connected to the output cable. Please check the laser output carefully to prevent dust or other contamination. Use special paper when cleaning the laser output lens.
- c) If the laser is used in accordance without the method specified in this manual, the laser may be in abnormal working status and cause damage.
- d) It is strictly forbidden to install the laser output when the laser is in operation.
- e) Do not look directly into the laser output. Be sure to wear protective glasses when operating the laser.



- ◆ Do not expose this product to high humidity (>95%)
- ◆ Do not let this product work below the dew point temperature

Table 4 The Constant Dew Point Table

AMBIENT DEW POINT									
Room Temperature (°C)	Maximum Relative humidity								
	20%	30%	40%	50%	60%	70%	80%	90%	95%
20	-3.5	2	6	9	12	14.5	16.5	18	19
25	0.5	6	10.5	14	16.5	19	21	23	24
30	4.6	10.5	15	18.5	21.5	24	26	28	29
35	8.5	15	19.5	23	26	28.5	31	33	34
40	13	20	24	27.5	31	33.5	36	38	39
	Laser operating temperature range								

## 2.6 Precautions for Use

- a) Before supplying the power to the device, make sure that the correct voltage of the AC power source is used (See Table 3 for the laser model and corresponding input voltage). Failure to connect power source correctly will damage the device;
- b) Failure to follow the instructions may cause malfunction and damage to the device, such damage is not covered by warranty.
- c) It is very important to ensure the cleanness of the calibrated laser output head, otherwise it will cause irreparable damage to the laser.
- d) Please inspect the output head carefully for dust or other contamination. Use appropriate lens paper to clean it if necessary. Do not touch the output lens at any time; as well as remember to cap the output head when it is not in use, and make sure the cap is clean;
- e) Failure to follow the specified instructions may result in the loss of laser power, and such loss will not be covered by the warranty.

## 2.7 Specifications

The specifications are listed in the following table

Table 5 Specifications

Table 6 Product Specifications Model	C3000S	Test Conditions
<b>Optical Specifications</b>		
Nominal Output Power (W)	3000	
Operation Modes	CW/Modulated	
Polarization State	Random	
Power Adjust Range(%)	10~100	
Emission Wavelength(nm)	1080±5	Nominal Output Power
Output Power Instability(%)	±1.5	Nominal Output Power
		Operation Time: ≥5h
		Ambient Temperature: 22±1℃
Modulation Frequency(Hz)	1~5,000	Nominal Output Power
Red Guide Laser Power(mW)	0.5~1	
<b>Optical Output Characteristics of QBH head</b>		
Beam Quality(mm×mrad)	1.5~2	Nominal Output Power
Fiber Core Diameter(μm)	50 (with 100、200 options)	
Numerical Aperture	0.2	
Delivery Cable Length(m)	20	Length customizable
<b>Electrical Characteristics</b>		
Power Supply	380±10% V AC、50/60Hz	
Max. Power Consumption(W)	10000	
Control Mode	RS-232/AD/Ethernet	
<b>Other Characteristics</b>		
Dimensions(W×H×D) (mm)	485*163.5*736 (include. handles))	
Weight(kg)	<40	
Operating Ambient Temperature (℃)	10~40	
Humidity (%)	30~70	
Storage Temperature (℃)	-10~60	
Cooling Method	Water Cooling	

### 3 Installation

#### 3.1 Dimensions

Figure 2 shows dimensions of RFL-C3000S.

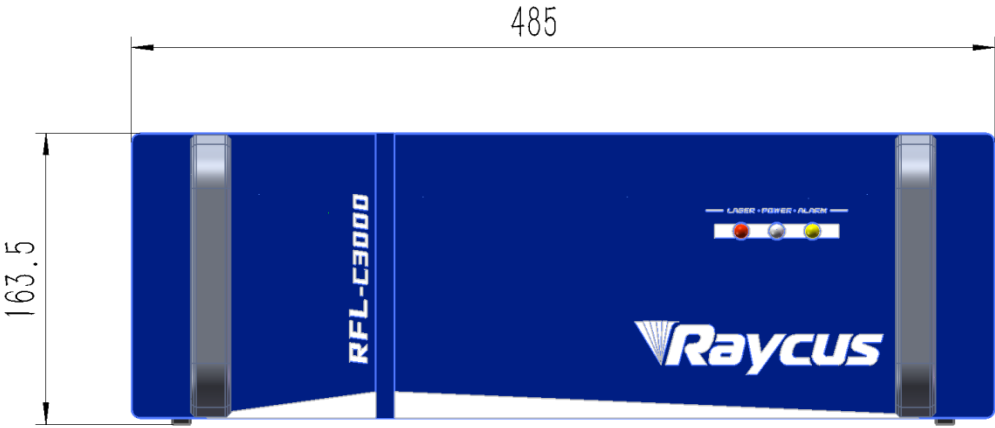

Figure 2 (a) Front panel view of RFL-C3000S(unit: mm)

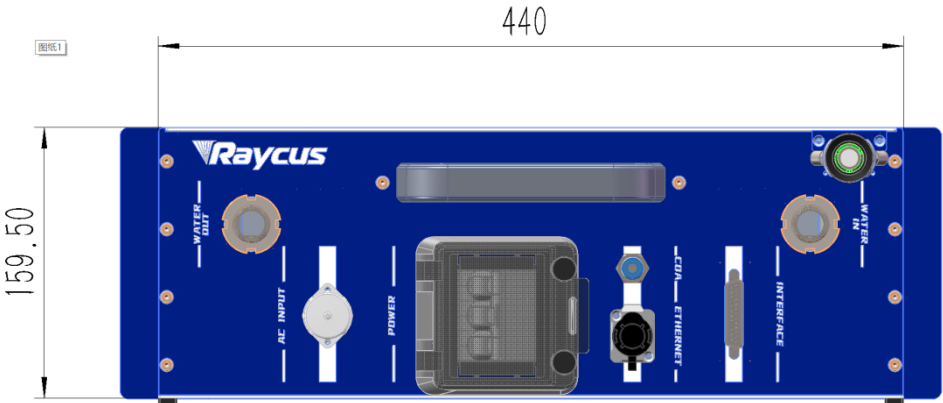

Figure2 (b) Rear panel view of RFL-C3000S (unit: mm)

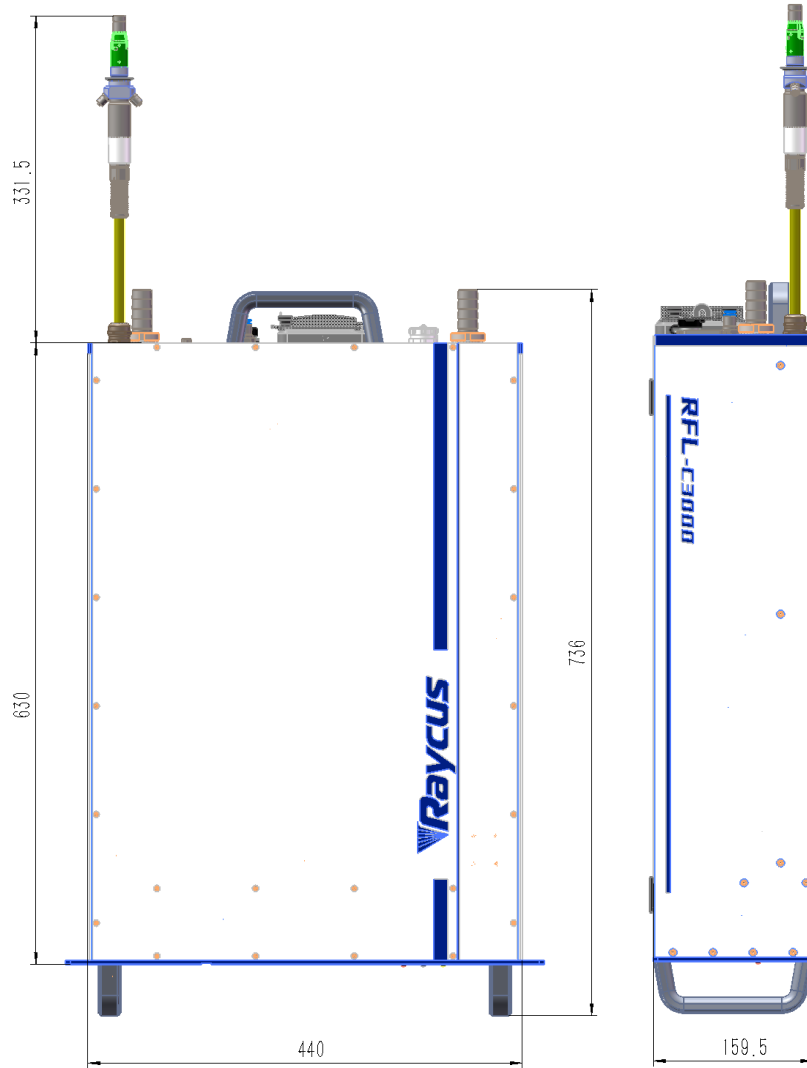

Figure2 (c) Top and Side view of RFL-C3000S (unit: mm)

### 3.2 Output Head and Installation

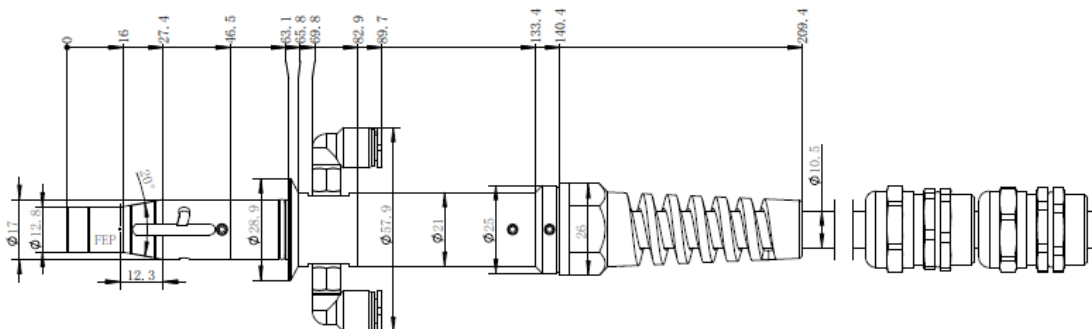



Figure 3B Dimensions of iQB Output Head

The QBH and iQB laser output head of RFL-C3000S are all the standard IQB interface. The specific appearance and dimensions are shown in Figure 3 above.

	<p><b>CAUTIONS:</b></p> <ul style="list-style-type: none"> <li>◆ Inspect the output lens before installing the output head to the processing head. Clean the output lens if necessary.</li> <li>◆ It is strictly prohibited to disassemble the output head by personnel not approved by Raycus, or the warranty is void.</li> </ul>
---	---

### 3.3 Cooling Requirements

Table 6 Cooling Requirements

Model	RFL-C3000S
Cooling Capability(W)	>7500
Minimum Flow(L/min)	22
Maximum Pressure(Bar)	7
Pipe Inner Diameter(mm)	19
Water temperature of cooling system(°C)	$22 \pm 1^{\circ}\text{C}$

- a) The water temperature setting of cooling system:  
 $22 \pm 1^{\circ}\text{C}$  (RFL-C3000S)
- b) Cooling water requirements:
  - It is recommended to use purified water.
  - In order to prevent mould growing that may lead to pipe blockage, we recommend to add alcohol about 10% of the total volume.
  - If the product is used in an environment that ambient temperature is between  $-10^{\circ}\text{C}$  and  $0^{\circ}\text{C}$ , we recommend to use 30% alcohol, and replace it every two months.
  - If the product is used in an environment that ambient temperature is below  $-10^{\circ}\text{C}$ , please use dual-system chillers (with heating function) and ensure uninterrupted operation of the cooling system.
- c) Requirements for output cable cooling system:
  - Rate of liquid flow: 1.7-2.0 L/min;
  - Pressure of liquid flow:  $< 0.6 \text{ MPa}$  at the inflow;

- Type of liquid exchange junction: SMC MS-5H-6:
  - Type of tube: outer diameter 6; inner diameter 4;
  - Direction of cooling liquid: unidirectional; connect the tube with the water-pipe strictly according to direction shown on the layer of the tube;
  - Type of liquid: deionized water, condensed water, pure water;
  - PH value of liquid: 5.5 - 9;
  - Filter is needed for the cooling system, and the size of the solid residual practicals should be within 100um;
  - Maximum temperature of liquid: 45°C:
  - Minimum temperature of liquid: greater than the saturated dew-point 5°C;
  - Additive to the liquid: satisfies the requirements of PH value and size of solid residual practicals as above;
  - Radius of the bending of the armored pipe: off-work state (i.e. transportation and reservation): minimum radius of bending  $\geq 20$  cm; in-work state: minimum radius of bending  $\geq 30$  cm;
  - Long-term vibration  $< 2$  G; Impact action  $< 10$  G.
- d) Other requirements for chiller:
- When starting the cooling system for the first time, check the entire water system and the joint for water leakage. The external water pipe must be installed and connected according to the inlet (IN) and outlet (OUT) by the laser. Otherwise, the laser may not work properly.
  - If you will not use the laser for a long time, water must be emptied from the product, and then both the inlet and outlet must be blocked with the nuts we provide. Failure to do so may lead to permanent equipment damage.



**CAUTION:** Please set the water temperature in strictly accordance with the requirements above. Too low temperature may lead to condensation on the laser module and the output cable. This can cause serious damage to the equipment.





**CAUTION:** Make sure that the water temperature reaches the set point and the cooling system is working well before you start the laser.  
[summer:  $22 \pm 1^\circ\text{C}$  (RFL-C3000S) ; winter:  $22 \pm 1^\circ\text{C}$ ]

### 3.4 Installation Procedure

- a) Place the product in a still and stable position;
- b) Check if the power supply has the correct voltage (See Table 5 for the laser model and corresponding input voltage), and the earth line is connected, make sure it is firm and reliable;
- c) Connect the power cable and control cable to the product when power supply is OFF;
- d) Insert the water pipes into the inlet and outlet port;
- e) Check the output head and clean it if necessary. This procedure must be performed by personnel of Raycus or authorized by Raycus. Make sure the environment is clean, or the output cable may be contaminated.
- f) Prevent the delivery cable from treading, pinching or excessive bending during installation;
- g) During the installation and dis-assembly process, please take care to handle the laser output head gently, avoiding any shock;
- h) In the installation of laser output cable and output head process, please make sure that the surrounding environment is clean, otherwise it may pollute the output head (do not use fans, which actually may bring more dust);
- i) The minimum bending radius of the output fiber cable of the laser should not be less than 20 cm under the non-working conditions, and the minimum bending radius should not be less than 30 cm when the laser is working.

	<p><b>CAUTION:</b></p> <ul style="list-style-type: none"><li>◆ All the cables can only be connected when power supply is OFF. Hot plug may damage the laser.</li></ul>
---	--

	<p><b>CAUTION:</b></p> <ul style="list-style-type: none"><li>◆ The laser output optical cable should be kept as natural as possible and not be distorted.</li><li>◆ The too small bending radius of the output fiber cable will damage the laser.</li></ul>
---	---

	<p><b>CAUTION:</b></p> <ul style="list-style-type: none"><li>◆ Make sure the aperture and the cavity of the processing head is clean;</li><li>◆ Keep the protective cap properly, prevent it from contamination; Or the aperture will be contaminated when capped.</li></ul>
---	--

## 4 Using the Product

---



Raycus CW fiber laser has stopped using the HyperTerminal, so the HyperTerminal will not work when the laser is powered on. Please clip the address below to download the latest PC software and the relevant manual.

---

### 4.1 Front Panel

Figure 4 shows the front panel of RFL-C3000S (take RFL-C2000 for example):

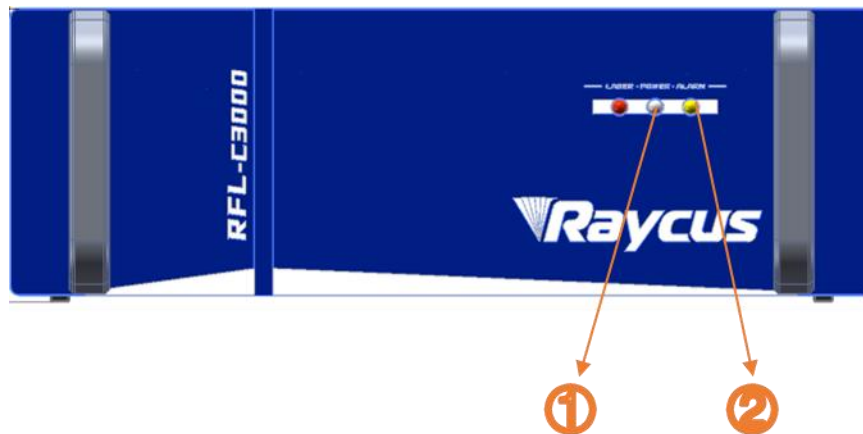

Figure 4 Front Panel of RFL-C3000S

1. **POWER:** Power Indicator, **GREEN**, indicates that the power is switched on.
2. **ALARM:** Alarm indicator, **YELLOW**, indicates an error condition.

### 4.2 Rear Panel

Figure shows the rear panel of RFL-C3000S:

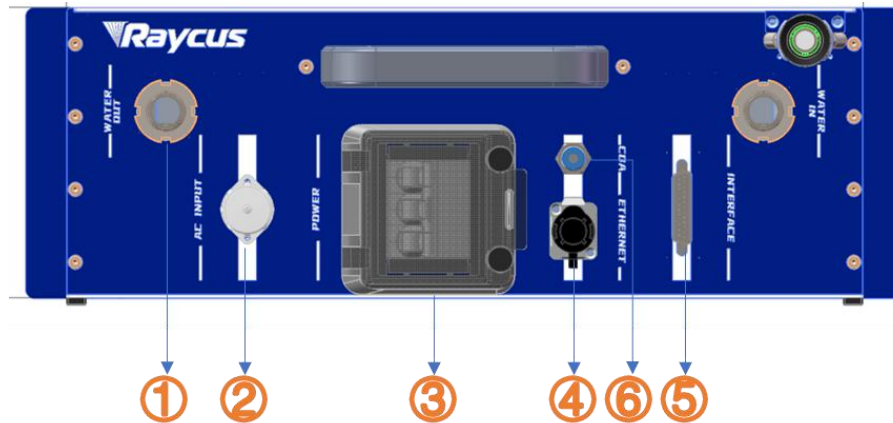

Figure 5 Front Panel of RFL-C3000S

1. **WATER:** Pipe connectors, the inlet and outlet for cooling water to flow in and return.  
(See Table 6 for the laser model and corresponding water pipe size for cooling system requirements)
2. **AC INPUT:** The socket for power supply input that can only be matched with the plug on the power cord we provided.
3. **POWER:** Air switch to control the switching of AC.
4. **ETHERNET:** Ethernet interface. It can provide remote control and storage alarm information for the laser.
5. **CTRL-INTERFACE:** Control interface, this interface is a male 24-needles connector and it's multi-functional. The end users can set the control mode and input analog control signal with the interface, as well as get the fault signal from it.
6. **CDA:** Clean Dry Air input. Clean dry air is input here to prevent dew formation.

The application of CDA:

If the CDA is provided by the customer, it must be cooled and dried by the dryer, then filtered by 5 $\mu$ m-particle and 0.3 $\mu$ m-particle filter, and 0.1 $\mu$ m atomized lubricator. The temperature of CDA must be in the range of 5~40 $^{\circ}$ C, and the highest dew point is 0 $^{\circ}$ C (It is suggested the temperature of CDA is 5 $^{\circ}$ C below the temperature of cooling water). The pressure of CDA is below 0.1MPa, the flow rate is 10 LPM, and the outer diameter of pipe mated with the connector is 6mm.

If the CDA filter module provided by Raycus is used, the CDA should be also cooled and dried by the dryer, and the pressure should be below 0.8MPa, the outer diameter of pipe mated with the connector is 6mm.

The CDA should be input 30 min before the start of the laser. If the ambient temperature is below 25°C and the humidity is below 50%, the CDA is unnecessary.

### 4.3 Power Connection



	<p><b>CAUTION:</b> Before connecting the product to AC supply source, you must check for sure that the AC supply you will apply is in accordance with the specifications provided in Table 3 or Table 5.</p>
---	--

Table 7 Power Connection Requirements

Model	RFL-C3000S
Supply Source	380±10% V AC 50/60Hz
Power Cord	
One End of Power Cord	Four wires labeled L1, L2, L3 and PE.
Sign Description	L1, L2, L3-> Phase Line PE-> Protective Earth
Note	One end of the power cord is a plug, insert it into the socket 'AC INPUT' on the rear panel. Notice that the plug is wrong-side preventing. After inserting it, lock it with the lever.

## 4.4 Interface Definitions

### 4.4.1 CTRL-INTERFACE Definitions

The CTRL-INTERFACE is for laser control, the designation and definition is below:

Table 8 Definitions of 24 pin Ctrl Interface

PIN No.	Name	LineMark	Type	Level	Drive Current	Typical Response Time	Description
1	NULL		Contact Closure Input	5VDC	<1A	<500ms	Dry contacts pair, connect or disconnect only
2	Interlock1A	ITL-A					
3	Interlock1B	ITL-B					
4	NULL						
5	RS232Tx	TX				120ms	Transmit Data
6	RS232Rx	RX					Receive Data
7	RS232Com	GND					RS-232 Return
8	Remote Key Switch	RPA	Contact Closure Input	24VDC	<1A	<1s	Activates the internal main power supply in REMOTE mode
9		RPB					
10	NULL						
11							
12	Analog Input to Control Current	0-10V	Analog Input	1-10VDC	1 mA	300us	Analog Input 1-10 VDC= 10 – 100% Setpoint
13	Analog Output Power Monitor	AOUT	Analog Output	0-5.0VDC	10mA	30 μs	Analog Output 0-5 VDC (Refer to factory inspection report for details)
14	Isolated Analog Com	AGND	Return				Return for signals on pins 12, 13
15	Modulation+	MOD+	Digital Input	24VDC	6 mA	20 μs	5 -24 VDC Input
16	Modulation-	MOD-	Return				Return for signal on pin 15
17	EXTVCC	EVCC	Source Input	24VDC	100mA	1ms	External Source Input
18	Emission Enable	LAS-C	Digital Input	24VDC	6 mA	1ms	Positive edge activates emission in REMOTE mode
19	READY	RDY	Digital output	24VDC	100mA	120ms	High=Laser is ready

Table 8 Definitions of 24 pin Ctrl Interface (Renew)

PIN No.	Name	LineMark	Type	Level	Drive Current	Typical Response Time	Description
20	System Common	EGND	Return				Return for pin 17、 18、 19、 21
21	AD/RS	AD/RS	Digital Input	24VDC	6 mA	120ms	In REMOTE mode, connect pin 21 to 24V, the laser enters AD mode; connect to 20 or left unconnected, laser enters RS232 mode
22	System error (ERROR)	S-ERR	Digital output	24VDC	100mA	120ms	High=System error
23	NULL						
24	NULL						
25	NULL						

#### 4.4.2 SERVICE Security interface

The Service Security Interface is pin 2 and pin 3 of CTRL-INTERFACE.

- If the two pins 2 and 3 are disconnected, the laser will immediately stop emitting light, and the laser Ready signal output will change to low level. Be sure to short-circuit pins 2 and 3 before using the laser. If it is not short-circuited, the laser will display Interlock alarm after power-on.

	<p>Interlock interface must not be connected to active signal, otherwise it will cause interface damage and laser alarm.</p>
---	--

### 4.4.3 TCP/IP Interface Configuration

The default IP address of this product is 192.168.0.10, only supporting UDP communication. The laser listens for connection on port is 8098, and the command must be sent in a single data string.

Table 9 The pin definitions of Ethernet interface

PIN	FUNCTION	DESCRIPTION
1	TX+	TRANSMIT+
2	TX-	TRANSMIT-
3	RX+	RECEIVE+
4	N/C	NONE
5	N/C	NONE
6	RX-	RECEIVE-
7	N/C	NONE
8	N/C	NONE

For better communication stability, recommend to use this interface first.

#### Steps of Ethernet connection:

- Step 1:** Open the RaycusPC software, click "Session→RS232 (or Ethernet)" to make the PC communicate with the laser, and then click "Tool→Laser IP Set" to enter the laser IP address setting;
- Step 2:** The default password is "1122334455667788". After the verification is passed, read or set the new laser IP address;
- Step 3:** If you use Raycus software to control the laser, you need to find the folder where the Raycus software is located, open the laser configuration file "config.xml", and write the newly laser IP address. If you do not use Raycus software, please go to step 4;
- Step 4:** Configure TCP/IP, select "Use the following IP address:", manually assign an IP address, and the IP address of your computer must be in the same network segment as

the laser IP address, and assign a subnet mask address. The default is 255.255.255.0, click the "OK" button to confirm the settings and exit.

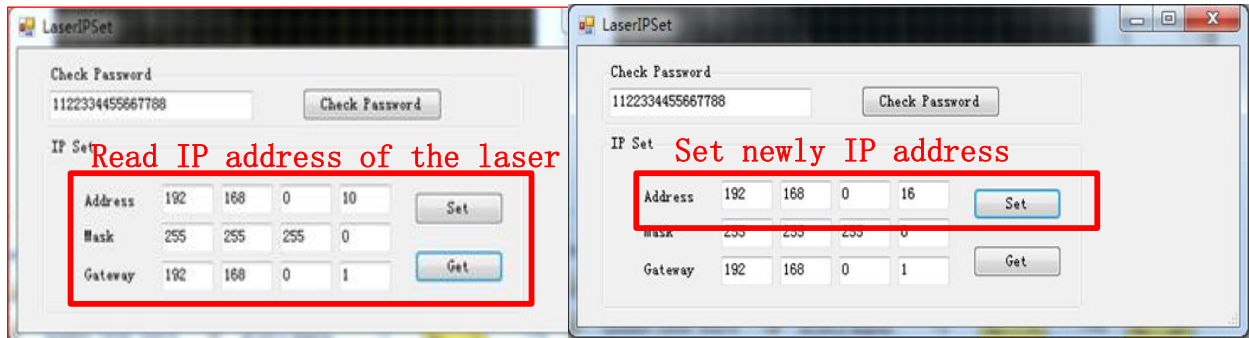

If you do not use Raycus software, please go to the step 4

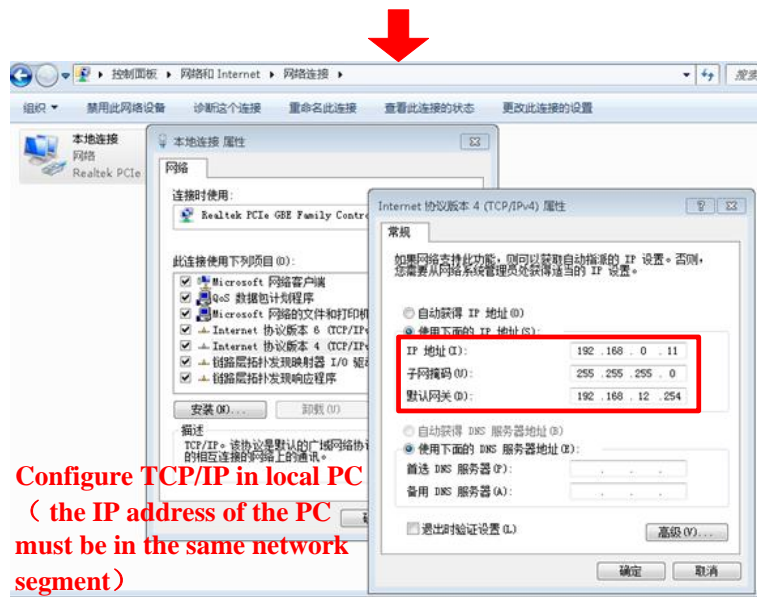
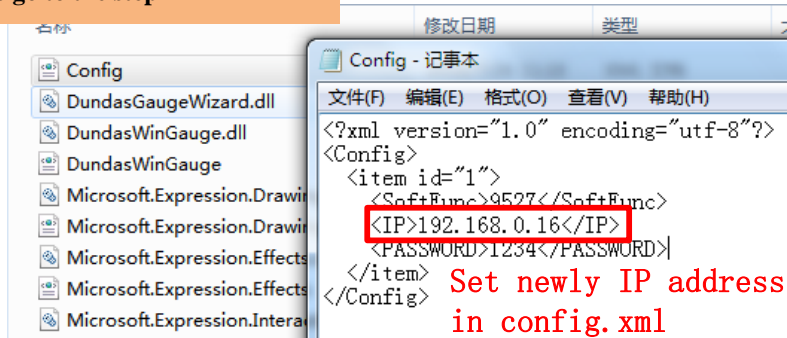

Figure 6 Steps of Ethernet Connection

## 4.5 Steps of Installation

- a) Carefully takeout the laser from the box and move it to the installing position and then lock the casters;

- b) Remove the output cable protective cap and check the output lens for dust with strong light and clean it if necessary, then cover the output cable protective cap;
- c) Install the output cable on the processing equipment according to the actual situation (install the output head cooling water pipe at the same time), pay attention to the output cable and head, then remove the protective cap and confirm that the output lens is clean and install the output head.;
- d) Connect cooling water pipe;
- e) Connect the control line and power according to the control mode.

## 4.6 Steps of Starting

All electrical connections must be finished before the laser is powered on;

Make sure the air switch is OFF and the emergency stop button (EMERGENCE STOP) on the front panel of the laser has been pressed down.

- a) Make sure that the pins 2 and 3 of the 24-pin are closed;
- b) Turn on the chiller and check leakage. If there is no water leakage, turn off the chiller and wait for the laser to turn on.
- c) Turn on the air switch and release the emergency stop switch.

**Note:** RFL-C3000S has an air conditioner and it starts to run as the emergency stop switch is released. In order to avoid damage the laser caused by condensation when the working temperature and relative humidity of the laser are in the dew point area [*the blue area in Table 4*], for RFL-C3000S please wait for the air conditioner to run for 30 minutes before operate the laser later and for RFL-C100~ RFL-C1000 please improve the working environment.

- d) Let the chiller work;  
Turn on the key switch and start the laser.

# 4.7 Control Modes

## 4.7.1 Wiring in different modes

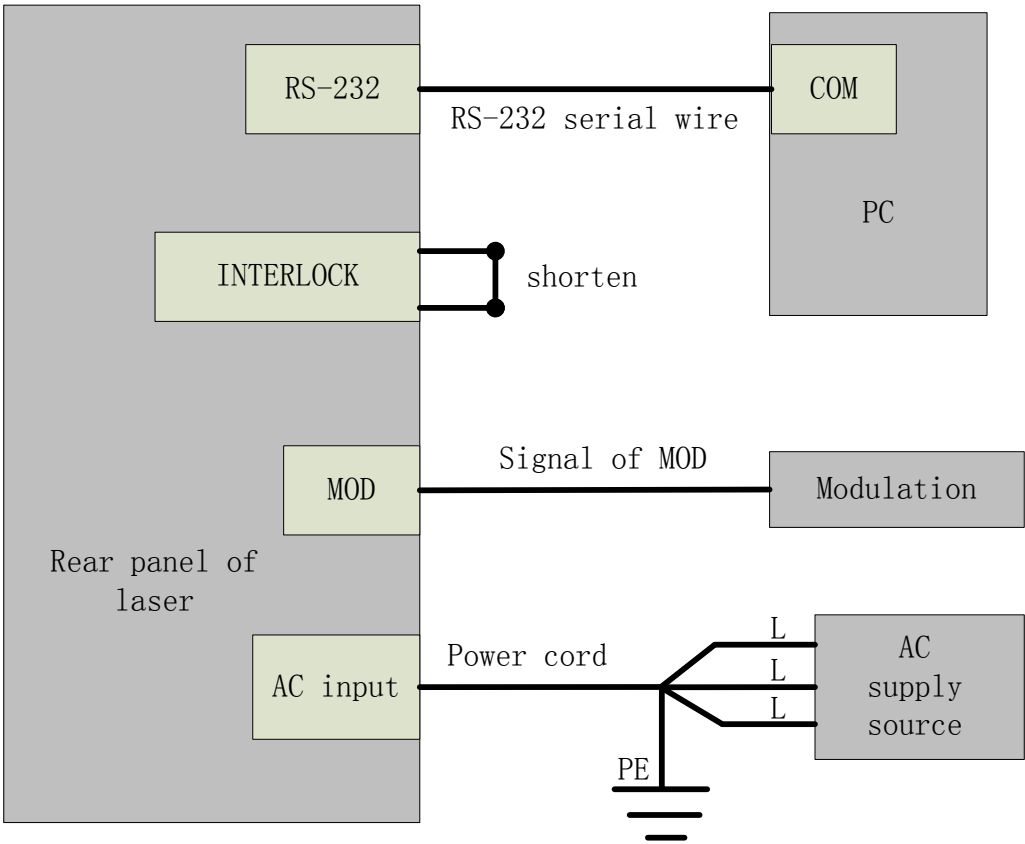

Figure 7 Wiring in RS-232 mode

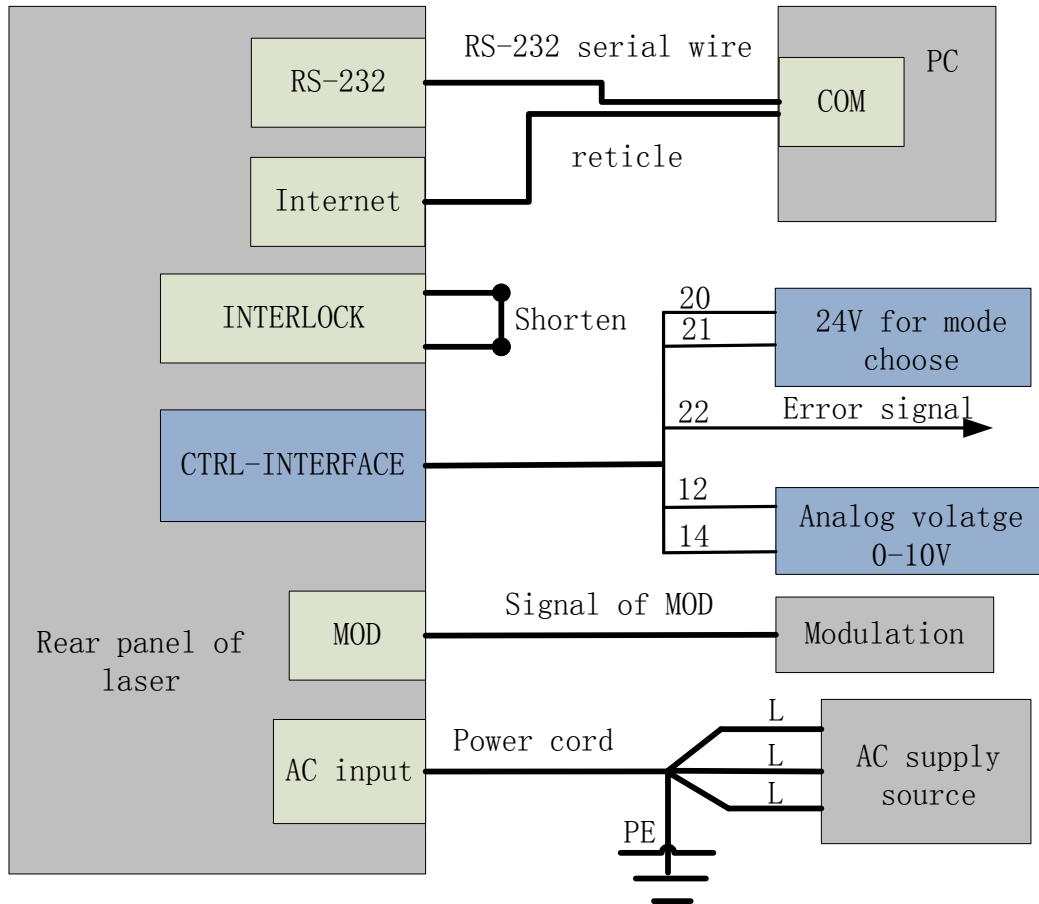

Figure 8 Wiring in AD mode

#### 4.7.2 Internal control mode

- a) Clockwise the key switch to the “ON” position and the “Power” indicator on the front panel illuminates;
- b) Waiting for 10s until the internal main control board circuit initialization is completed;
- c) Set the power of the laser (the power is set by 0-10V analog single when the AD mode is enabled, and the power is set by the PC software when the AD mode is disabled.) ;
- d) Press the “Laser” button (enable hardware emission) on the front panel;
- e) Send the start or stop emitting command to control the emission via RS-232.

See 4.8 to get the process of laser shutting down.

### 4.7.3 External control mode

**Modulation Mode:** When the duty cycle of the internal pulse is set to 100%, the laser operates in external modulation mode. The laser is controlled by the user's "modulation" signal provided by the external MOD interface. For the time sequencediagram, see [4.7.5 Control sequence diagram].

**Gate Mode:** When the duty cycle of the internal pulse is less than 100%, the laser operates in Gate mode. The laser is controlled by the MOD signal and internal frequency. MOD signal is used to start and stop internal pulse signal. For the time sequencediagram, see [4.7.5 Control sequence diagram].

The laser operates on external modulation mode by default.

- a) Turn the key switch to the “REM” position (or turn the key switch to OFF, short the 24-pin interface PIN 2, 3) and the “Power” indicator on the front panel light on;
- b) Wait for 10s until the internal main control board circuit initialization is completed.
- c) Set the power of the laser (the power is set by 0-10V analog single when the AD mode is enabled, and the power is set by the PC software when the AD mode is off.) ;
- d) Give the emission enable signal in one of the following ways:
  - Press the “Laser” button (enable hardware emission) on the front panel;
  - PIN 18, 20 of the 24-pin control interface is applied to 24V (enable hardware emission);
  - Send the start or stop emitting command (enable hardware emission) to control the emission by Raycus software;
- e) The laser is controlled by the user's "modulation" signal provided by the external MOD interface.

See 4.8 to get the process of laser shutting down.

#### 4.7.4 AD mode

When PIN 20, 21 of the 24-pin control interface is applied to 24V, the laser enters the external AD mode, and the power of the laser is controlled by the voltage obtained by PIN12-14(1V-10% power, 10V-100% power).

When PIN 20, 21 is applied to 0V or left floating, the power of the laser is set by serial port or Ethernet.

#### 4.7.5 Control sequence diagram

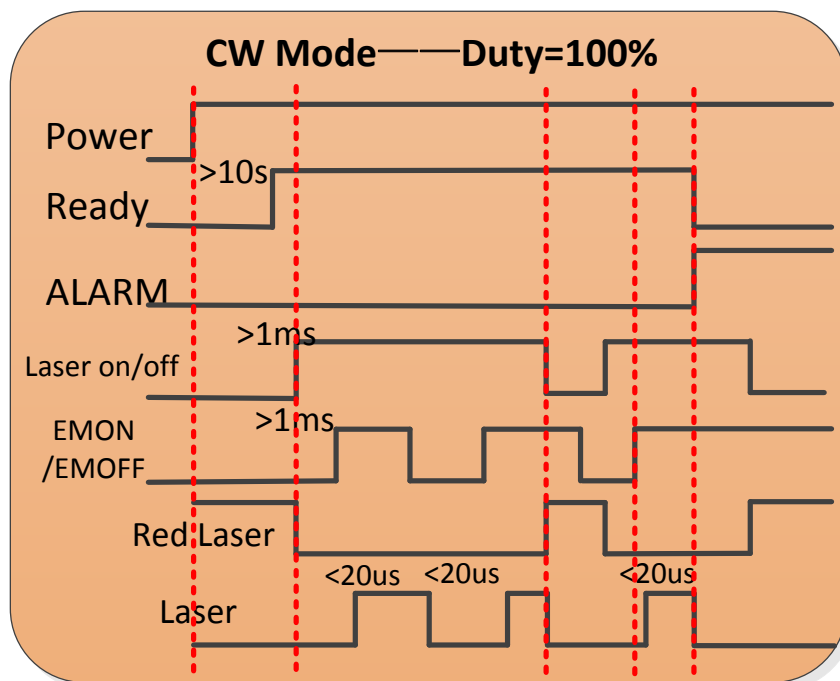

Figure 9 Control sequence diagram of CW mode

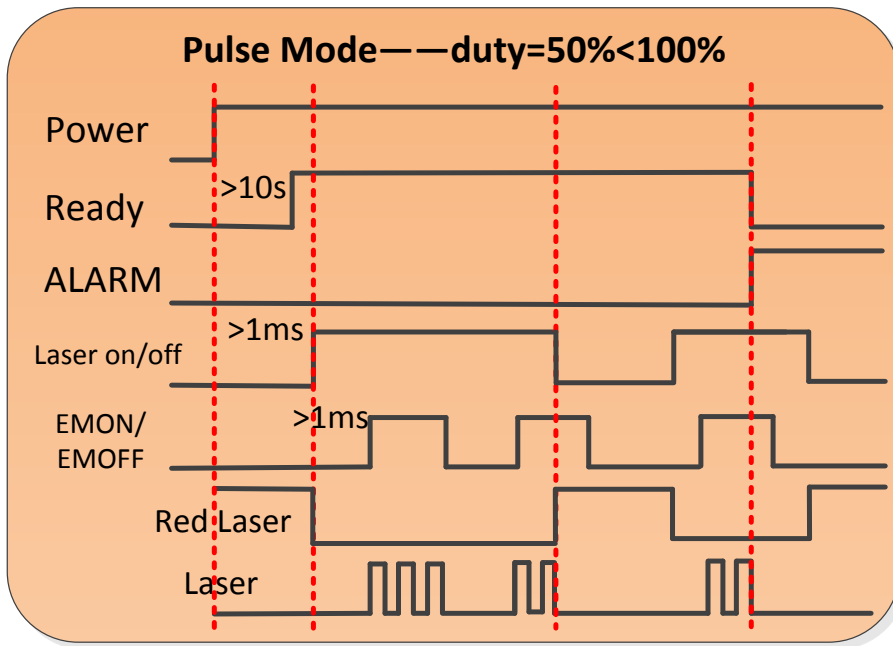

Figure 10 Control sequence diagram of Pulse mode

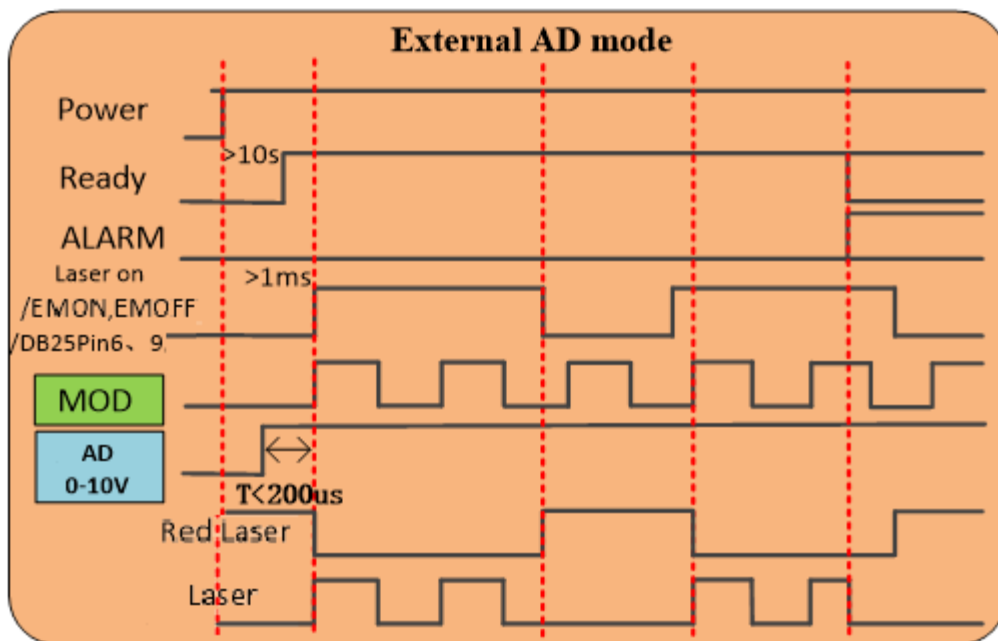

Figure 11 Control sequence diagram of External AD mode

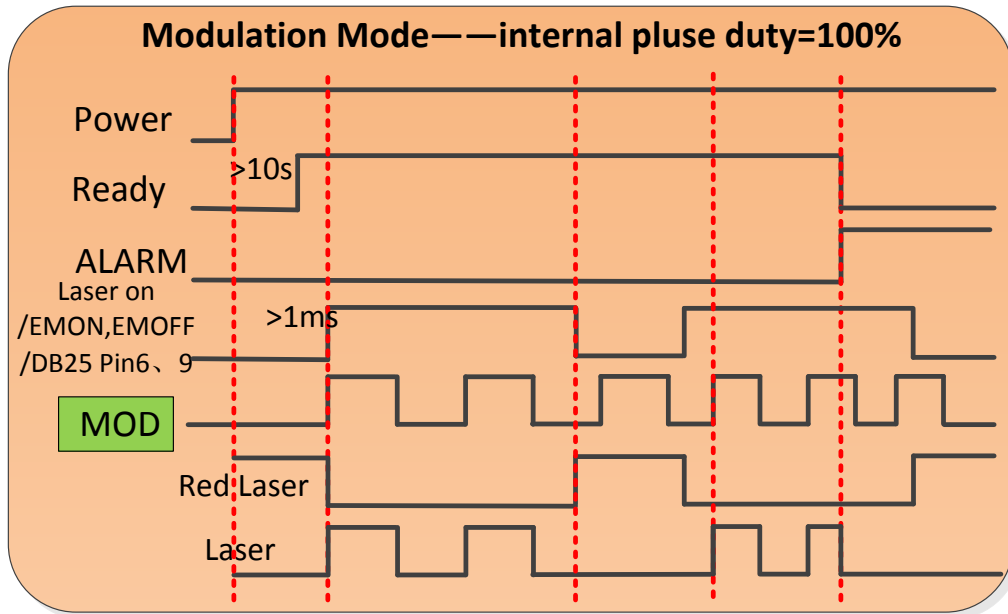

Figure 12 Control sequence diagram of Modulation mode

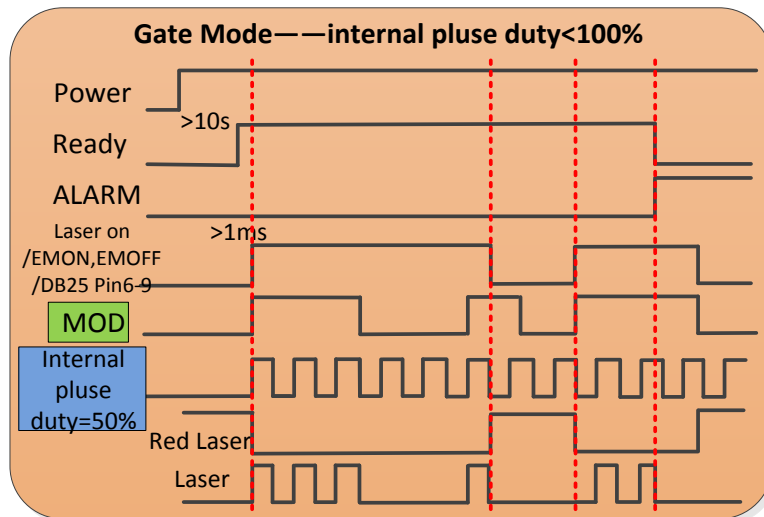

Figure 13 Control sequence diagram of Gate mode

### 4.7.6 Guide Lasercontrol

Turn the key switch to the "REM" or "ON" position and power on the laser, "POWER" green indicator is illuminated and the red guide laser is output. The red guide laser is off when "LASER" button in front panel is pressed down or command "EMON" is sent via RS-232, while the red laser is on when "LASER" is released or command "EMOFF" is sent via RS-232.



CAUTION: The red laser and the laser emission cannot be output at the same time. If there is no red light output, please check if the "LASER" button is released and command "EMOFF" is sent.

## 4.8 Steps of shutting down

Please turn off the laser in the order below:

- a) Turn off the emission;
- b) Turn the key switch to the "OFF" position and release "LASER" button;
- c) Turn off the chiller;
- d) If the product have air conditioner please waiting 10 minutes for the air conditioner to continue working. If the laser does not have air conditioner, please ignore this step;
- e) Disconnect the air switch;
- f) Cover the output head protection cap;

## 5 Alarms and Solutions

### 5.1 Alarms Display

When the laser establishes communication with the client software, all alarm states of the laser can be displayed on Raycus software homepage, as shown in Figure .(Download the Rsyncus software and software manual, please log in to Raycus official website)

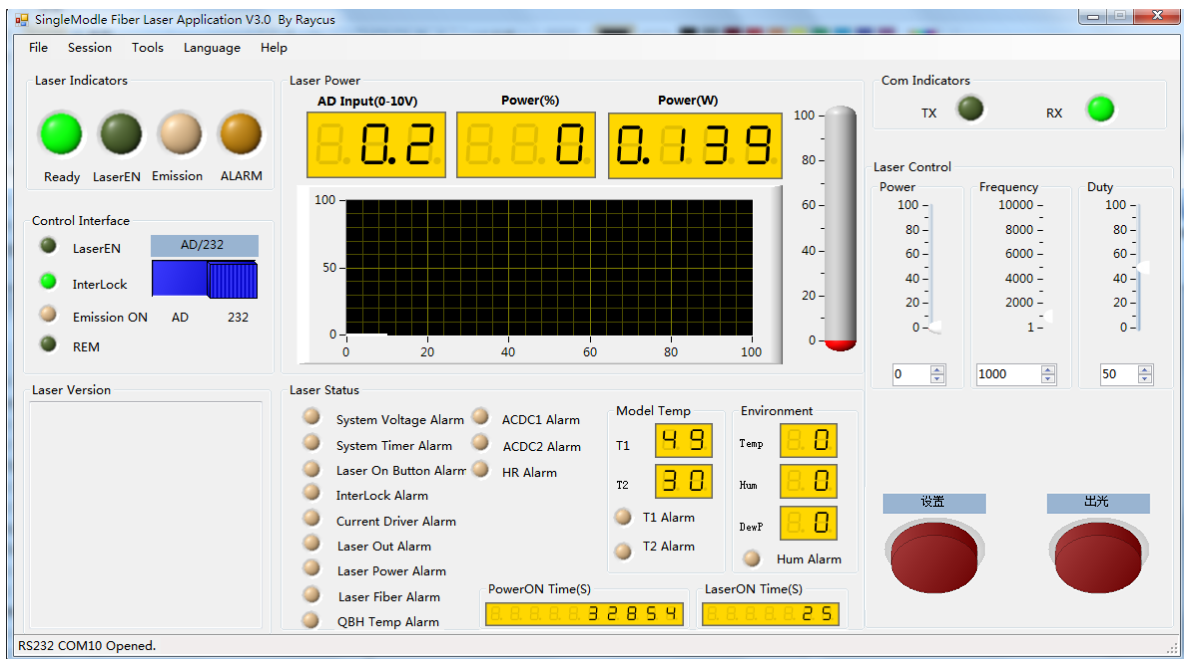

Figure 14 The homepage of Raycussoftware

If any alarm occurs (except for Interlock alarm) when the laser is running, the homepage will display the alarm that occurs, and the ALARM light (yellow) on the front panel of the laser will light up, the laser will stop emitting and lock.

When the Interlock is abnormal, the output of Ready signal is low, and the Interlock state is abnormal in the software homepage, but the laser is not locked, and the ALARM light (yellow) is not lit. The output of Ready signal is on high level when the Interlock is normal.

### 5.2 Alarm solutions

The instructions and solutions of alarms are as follows:

Table 10 Instructions and solutionsfor alarms of laser

Alarm name	Alarm instructions and solutions
System Timer Alarm	<p><b>Instruction:</b> The internal clock of laser is abnormal.</p> <p><b>Solution:</b> If it displays this alarm, please contact Raycus.</p>
Laser On Button Alarm	<p><b>Instruction:</b> This alarm occurs when the “LASER” button on the front panel of the laser has been pressed before the laser was powered on.</p> <p><b>Solution:</b> Please power off the laser and pop upthe”LASER” button. Re-power the laser and check if the alarm is released. If this alarm continues to occur, please contact Raycus.</p>
Interlock Alarm	<p><b>Instruction:</b> Occurs when the Interlock is disconnected.</p> <p><b>Solution:</b> Short the Interlock pins and restart the laser to try. If this error continues to occur, please contact Raycus.</p>
Current Driver Alarm	<p><b>Instruction:</b> Current Driver Alarm,thiserror occurs when the constant current driver board inside the laser is abnormal.</p> <p><b>Solution:</b> Restart the laser, If this error continues to occur, please contact Raycus</p>
Laser Out Alarm	<p><b>Instruction:</b> 1. Laser Out Alarm immediately occurs when the laser is powered.</p> <p><b>Solution:</b> The laser will auto-lock after two times of this error occurs successive, please contact Raycus.</p> <p>2. The laser will get this error when it does not emit with correct settings.</p> <p><b>Solution:</b> Close the shutter and pop up the “LASER” button on the front panel of the laser to check if the red guide light is output normally when it isn’t emitting. If there is no red guide light, please stop using the laser immediately and contact Raycus. If the red guide light output normally, please restart the laser to try, if the alarm continues to occur, please contact Raycus.</p>

Table 10 Instructions and solutions for alarms of laser (Renew)

Alarm name	Alarm instructions and solutions
Laser Power Alarm	<p><b>Instruction:</b>            The alarm is generated when the emission of the laser cannot reach the set value. Power error occurs only when the laser is emitting.</p> <p><b>Solution:</b>            Restart the laser, if this error continues to occur, please contact Raycus.</p>
ACDC1 Alarm	<p><b>Instruction:</b>            ACDC1 Error, failure of the laser power supply or sudden power failure of the power supply system may cause an alarm.</p> <p><b>Solution:</b>            Check if the input AC voltage is normal. Restart the laser, if this error continues to occur, please contact Raycus.</p>
ACDC2 Alarm	<p><b>Instruction:</b>            ACDC1 Error, Overcurrent or overvoltage inside the laser may generate this error.</p> <p><b>Solution:</b>            Check if the input AC voltage is normal. Restart the laser, if this error continues to occur, please contact Raycus.</p>
T1/T2 Alarm	<p><b>Instruction:</b>            Low temperature/high temperature alarm of the laser. The sensor in the laser detects an abnormal temperature inside the laser. A high-temperature / low-temperature error occurs when the temperature at the monitoring point exceeds the set upper / lower limit.</p> <p><b>Solution:</b>            High temperature alarm, please check if the water-cooling system is normally working, the water temperature is set correctly, and the water connection is correct. When the water cooling system works normally and the water temperature drops below 30 °C, restart the laser. If the alarm continues, please contact Raycus.</p> <p>Low temperature alarm, please check if the actual water temperature of the water is too low. In addition, a low ambient temperature may also cause a low temperature alarm when the laser is cold. Please wait until the water temperature of the water rises above 10 °C. If the alarm continues, please contact Raycus.</p>

Table 10 Instructions and solutions for alarms of laser (Renew)

Alarm name	Alarm instructions and solutions
Hum Alarm	<p><b>Instruction:</b> The Hum Alarm of the laser, the internal temperature of the laser detects that the current water-cooled plate temperature is lower than the internal dew point temperature, and there is a risk of condensation.</p> <p><b>Solution:</b> Immediately stop using the laser. For RFL-C100~RFL-C1000, please improve the working environment and after the ambient temperature is lower than internal temperature of the laser, restart the laser (advice to configure alone Air-conditioned room for the laser). For RFL-C100~RFL-C1000, please wait for the air conditioner to run for 30 minutes before restart the laser. If the alarm continues to occur, please contact Raycus.</p>

In addition to the above, if there are any questions or errors in using of the laser, you can contact Raycus to get help.

## 6 Warranty, Return and Maintenance

### 6.1 General Warranty

Raycus warrants that all Raycus fiber laser products are conformed to applicable product specifications under normal use and are free from defects in materials and workmanship. The warranties start on the date of shipment from Raycus for a period of time as set forth in the applicable purchase contracts or product specifications. Raycus has the right to choose to repair or replace any product that proves to be defective in materials and workmanship selectively during the warranty period. Only products with particular defects are under warranty. Raycus reserves the right to issue a credit note for any defective products produced in normal conditions.

### 6.2 Limitations of Warranty

The warranty does not cover the maintenance or reimbursement of our product of which the problem results from tampering, disassembling, misuse, accident, modification, unsuitable physical or operating environment, improper maintenance, damages caused by those who are not from Raycus due to excessive use or not following the instructions. Customer has the responsibility to understand and follow this instruction to use the device. Any damage caused by fault operating is not warranted. Accessories and fiber connectors are excluded from this warranty.

According to the warranty, client should write to us within 31 days after the defect is discovered. This warranty does not involve any other party, including specified buyer, end-user or customer and any parts, equipment or other products produced by other companies.

	<p><b>WARNING:</b> It is the customer's responsibility to understand and follow operating instructions in this User Guide and specifications prior to operation-failure to do so may void this warranty. Accessories and fiber connectors are not covered by this warranty.</p>
---	---

### 6.3 Service and Repair

- Do not open the device. There are no user serviceable parts, equipment or assemblies for user in this product. All service and maintenance shall be performed by qualified Raycus personnel.
- Please contact Raycus as soon as possible when problems under warranty about maintenance happened to the product.
- The product returned with permission should be placed in a suitable container.

➤ If any damage happened to the product, please notify the carrier in document immediately.

**We reserve the right to make changes in design or constructions of any of our products at anytime without incurring any obligation to make changes or install the same on units previously purchased.**

**All the items about warranty and service above provided by Raycus are for user's reference; formal contents about warranty and service are subject to the contract.**

---

**© 2022 Wuhan Raycus Fiber Laser technologies Co. Ltd, All Rights Reserved.**