



# Continuous-Wave Fiber Laser User Guide

适用机型: RFL-C2000S-HP RFL-C3000S-HP  
RFL-C4000S-HP RFL-C6000S-HP

Wuhan Raycus Fiber Laser Technologies Co., Ltd

## TABLE OF CONTENTS

<b>1. Safety Information .....</b>	<b>4</b>
1.1 Symbols Used in this User Guide .....	4
1.2 Laser Classification .....	4
1.3 Safety Labels .....	4
1.4 Optical Safety .....	6
1.5 Electrical Safety .....	6
1.6 Other Safety Rules .....	6
<b>2. Product Description .....</b>	<b>7</b>
2.1 Features .....	7
2.2 Package accessories .....	7
2.3 Unpacking and inspections .....	7
2.4 Operation Environment .....	8
2.5 Attentions .....	9
2.6 Specifications .....	10
<b>3. Installation .....</b>	<b>11</b>
3.1 Dimensions .....	11
3.2 Size and installation of output optical cable .....	12
3.3 Cooling system installation and requirements .....	12
3.4 Installation considerations .....	15
<b>4. Guiding .....</b>	<b>16</b>
4.1 Front panel .....	16
4.2 Rear Panel .....	17
4.3 Power connections .....	19
4.4 Control interface definition and connection .....	19
4.5 Laser installation sequence .....	30
4.6 Steps of Starting .....	30
4.7 Functions of Raycus software .....	30
4.8 Control mode selection .....	40
4.9 Red guide beam control .....	42
4.10 Laser power slow rise and fall mode .....	43
4.11 Programming Mode (Waveform Editing) .....	43
4.12 Steps of close .....	52
<b>5.Common alarms and handling measures .....</b>	<b>53</b>
5.1 Alarm display .....	53
5.1 Alarm Handling .....	54

<b>6. Warranty, Return and Maintenance</b> .....	<b>56</b>
6.1 General Warranty .....	56
6.2 Limitations of Warranty .....	56
6.3 Service and Repair .....	57
6.4 Scrapping Requirements .....	57

## 1 Safety Information

Thank you for choosing Raycus fiber laser. This User Guide provides important safety, operation, warranty and other information. Please read it carefully before you use this product. In order to ensure safe operation and optimal performance of the product, please follow the warnings, cautions, operating procedures and other instructions accordingly.

### 1.1 Symbols Used in this User Guide

	◆ <b>WARNING:</b> Refers to a potential hazard that may leads to a personal injury or death.
---	--

	◆ <b>CAUTION:</b> Refers to potential a hazard that may leads to a minor personal injury or product damage.
---	---

### 1.2 Laser Classification

This series of lasers are classified as a high power Class 4 laser instrument according to the European Community standards EN 60825-1, clause 9. This product emits invisible laser radiation at or around a wavelength of 1080 nm, and the total light power radiated from the optical output is greater than 300W~6000W (depending on model). Direct or indirect exposure of this level of light intensity may cause damage to the eyes or skin. Despite the radiation being invisible, the beam may cause irreversible damage to the retina and/or cornea. Appropriate and approved laser safety eyewear must be worn all the time while the laser is operating.

	◆ <b>WARNING:</b> The laser safety eyewear shall be used when this device is operating. The laser safety eyewear is selected according to the range of wavelengths emitted from this product. The end user must ensure that the laser safety eyewear being used protects against light emitted by the device over its entire range of wavelengths. Please verify that the personal protective equipment (e.g. enclosures, viewing windows or viewports, eyewear, etc.) being utilized is adequate for the output power and wavelength ranges listed on the product.
---	---

### 1.3 Safety Labels

The safety labels is as shown in Figure 1:

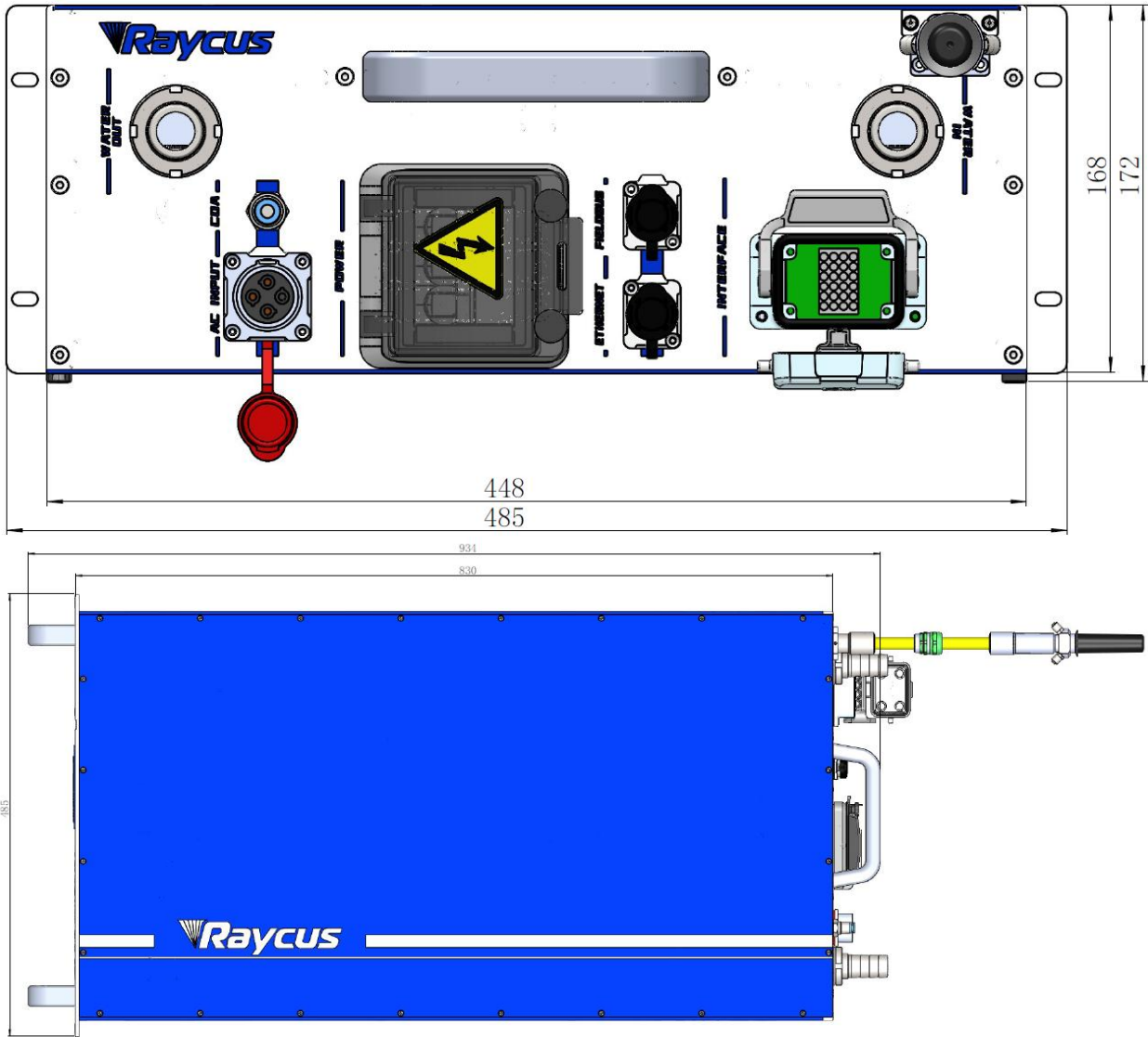



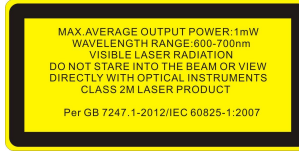







Figure 1 Safety labels

Laser safety labels include safety warning, laser output head warning, product certification, and product nameplate. The detailed description of the security identifier is as follows:

Table 1 Specifications of Safety Labels

 <p>English Label</p>  <p>Chinese Label</p>	 <p>English Label(eg:4000W)</p>  <p>Chinese Label(eg:4000W)</p>	 <p>English Label</p>  <p>Chinese Label</p>
<p>1: Laser Head Warning</p>	<p>2: Class IV Laser Product</p>	<p>3: Class 2M Laser Product Label for 1mW Guide Laser</p>

		
<p>4: CE Certification</p>	<p>5: Laser Label</p>	<p>6: Laser Radiation Hazard</p>
		
<p>7: Strong electric Hazard</p>		

### 1.4 Optical Safety

Any dust on the end of the collimator assembly can burn the lens.

	<p>◆ <b>CAUTION:</b> DO NOT emit laser when the protective cap is not removed, otherwise the lens or crystal will be damaged.</p>
---	---

### 1.5 Electrical Safety

- a) Make sure the product is firmly grounded through the PE line of the AC power cord

	<p>◆ <b>WARNING:</b> Any interruption from the protective earth will electrify the enclosure, which may result in personal injury for operators.</p>
---	--

- b) Make sure that the correct voltage of the DC power source is used.

	<p>◆ Wrong wiring mode or power supply voltage will cause an irrecoverable damage to the laser device.</p>
---	--

### 1.6 Other Safety Rules

- Do not directly look the laser fiber delivery cable connector when laser emitting.
- Do not use fiber lasers in dark environment.
- If this device is used in a manner not specified in this document, the protection provided by the device may be impaired and the warranty will be voided.
- There are no user serviceable parts, equipment or assemblies inside the product. All service and maintenance shall be performed by Raycus. In order to prevent electric shock, please do not break the seal or uncover the shield. Failure to comply with this instruction will void the warranty.

## 2 Product Description

### 2.1 Features

Raycus fiber laser, compared with traditional laser, has higher electro-optical conversion efficiency, lower power consumption and more excellent beam quality. It is compact and ready to use. Because of flexible laser output mode, it can be easy to integrate the device.

Main Features:

- Excellent beam quality
- High reliable and sealing
- High power stability
- Power continuously adjustable and fast switch response
- Maintenance-free operation
- High Electro-optical Conversion Efficiency
- Anti-reflection Capacity
- High modulation frequency and editable waveform Applications:
- Welding、5G、Infrastructure
- 3D printing
- Laser research

Applications:

- Welding、5G、Infrastructure
- 3D printing
- Laser research

### 2.2 Package accessories

Please refer to package accessories in the packing box.

### 2.3 Unpacking and inspections

Raycus fiber laser is delivered with the specially designed package to offer the fiberlaser maximal safety. Nevertheless, in order to prevent the occurrence of unpredictable circumstances during the transportation, please inspect all packaging once receiving the delivery. If you find any evidence of mishandling or damages, please keep the damaged material and contact the shipping agent and Raycus immediately.

Please double check if each listed content is included inside the package; and contactRaycus as soon as possible if there are any issue.

Take extra care when removing the unit from the package and make sure the fiber optic cable stays away from any possible collision and vibration. Please do NOT distort, bend or pull the output cable when unpacking the device; and avoid any collision to the fiber delivery cable connector.



◆ **CAUTION:** The fiber optic cable and fiber delivery cable connector are precise optic instrument, ANY vibration or impact to the fiber delivery cable connector, and twist or excessive bend to the cable will damage the instrument.

## 2.4 Operation Environment

The operation conditions are listed as the following table:

Table 2 Laser operation environment

Model	RFL-C2000S-HP	RFL-C3000S-HP	RFL-C4000S-HP	RFL-C6000S-HP
Power Voltage (V)	360~510V AC 50/60Hz			
Power Capacity (kVA)	7.5	11.5	15	22
Installation Environment	Flat and no vibration			
Ambient Temperature (°C)	10~40			
Relative Humidity (%)	30~70			

### Warning:

- a) Make sure the product is properly grounded before use.
- b) The laser output head is connected with fiber optic cable. Please inspect the output head carefully to prevent dust or other contaminations. Use appropriate lens paper to clean it if necessary.
- c) Failure to follow the instructions when operating the laser may cause malfunction and damage.
- d) It is not allowed to install the output head when the laser is in operation.
- e) Do not look into the output head directly. Wear appropriate protective eye glasses all the time when operating the laser



	<ul style="list-style-type: none"> <li>◆ Do not expose this product to high humidity (humidity&gt;95%)</li> <li>◆ Do not allow this product to operate at a temperature below the ambient dew point. (As shown in Table 3)</li> </ul>
---	---

Table 3 Comparison table of constant dew point at ambient temperature and relative humidity

Constant dew point table at ambient temperature and relative humidity									
Ambient temperature (°C)	Maximum relative humidity								
	20%	30%	40%	50%	60%	70%	80%	90%	95%
20	-3.5	2	6	9	12	14.5	16.5	18	19
25	0.5	6	10.5	14	16.5	19	21	23	24
30	4.6	10.5	15	18.5	21.5	24	26	28	29
35	8.5	15	19.5	23	26	28.5	31	33	34
40	13	20	24	27.5	31	33.5	36	38	39
Laser operating temperature range									

	<ul style="list-style-type: none"> <li>◆ Green areas: dew point temperature lower than laser cooling water temperature 22 °C, belongs to the scope of security</li> <li>◆ Red areas: dew point temperature is higher than 22 °C, more than laser cooling water temperature 22 °C, will produce condensation, measures must be taken prior to use. Measure 1, see Section 4.2. Access clean and dry air from CDA port to reduce relative humidity Measure 2, Install a cabinet air conditioner to lower the ambient temperature.</li> </ul>
---	--

## 2.5 Attentions

- a) Make sure that the correct voltage is used before connecting AC current. Failure to connect power supply will damage the device.
- b) Failure to operate the laser in accordance with the control or adjustment methods specified in this manual may cause damage.
- c) For the output laser collimated by the collimating lens, it is important to keep the collimating lens clean, otherwise it will damage the device.
- d) Please cap the output head when it is not in use. Do not touch the output lens at any time. Use appropriate lens paper and alcohol to clean it if necessary.
- e) Failure to follow the instructions may cause laser power loss, and such loss is not covered by warranty.

## 2.6 Specifications

Table 4 Product Specifications

Model	RFL-C2000S-HP	RFL-C3000S-HP	RFL-C4000S-HP	RFL-C6000S-HP	Test Conditions
<b>Optical Characteristics</b>					
Output Power(W)	2100±100	3100±100	4100±100	6100±100	
Operation Mode	CW/Modulated				
Polarization	Random				
Power Range(%)	10~100				
Emission Wavelength	1080±5				Nominal Output
Output Power Instability (%)	±1.5				Nominal Output Power Duration: ≥2h Operating Temp.: 22±1℃
Modulation Frequency(Hz)	1~5,000				
Red Guide Laser Power(mW)	0.5~1				
<b>Output Characteristics</b>					
BPP (mm*mrad)	3-4				Nominal Output Power
NA	0.2				
Fiber core ( μ m)	100				Customizable
Output cable length (m)	20				Customizable
<b>Electrical Characteristics</b>					
Power Supply	360~510 V AC、50/60Hz				
Max. Power (kW)	6	9	12	18	
Control Mode	Ethercat/AD/ PROFINET/Ethernet				
<b>Other Characteristics</b>					
Dimensions(W×H×D) (mm)	448×934×168(handleincluded)				
Weight(kg)	<65	<70	<75	<85	
Operating Ambient Temperature Range (°C)	10~40				
Humidity(%)	30~70				
Storage Temperature(°C)	-10~60				
Cooling Method	Water cooling				

RFL-C2000S-HP /RFL-C3000S-HP /RFL-C4000S-HP/RFL-C6000S-HP

### 3 Installation

#### 3.1 Dimensions

Figure 2 shows the external dimensions of the RFL-C2000S-HP/RFL-C3000S-HP/  
RFL-C4000S-HP/ RFL-C6000S-HP.(take C4000S as an example)

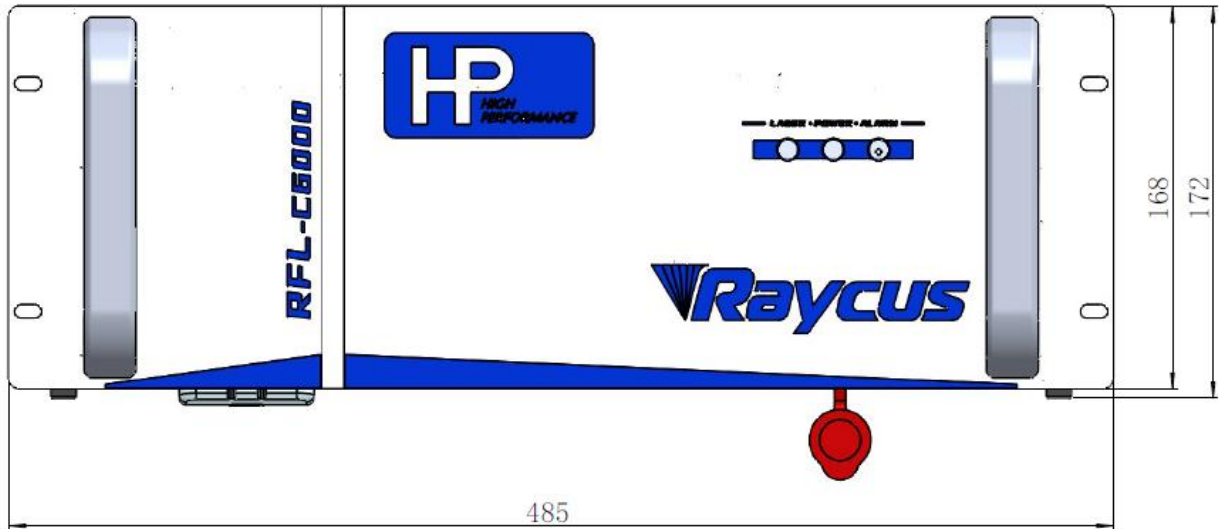

Figure 2 (a) Front view (Unit: mm)

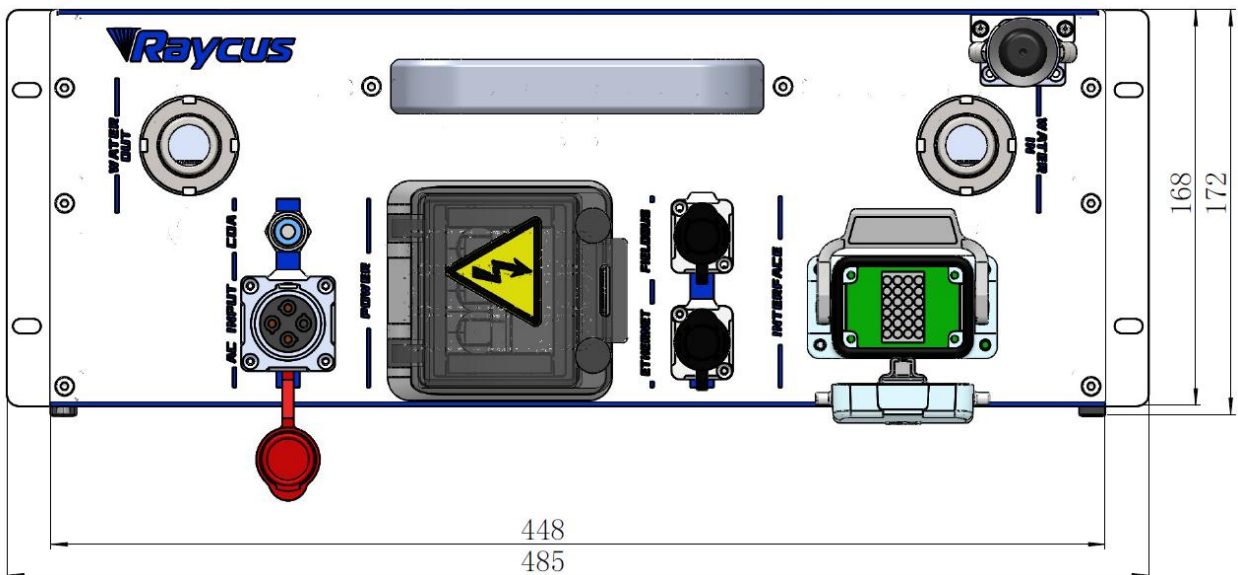

Figure 2 (b) Rear view (unit: mm)

RFL-C2000S-HP /RFL-C3000S-HP /RFL-C4000S-HP/RFL-C6000S-HP

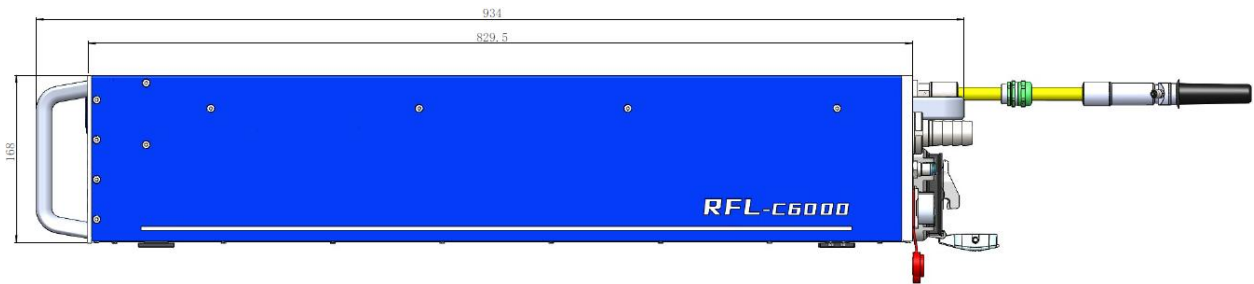

Figure 2 (c) Side view (Unit: mm)

### 3.2 Size and installation of output optical cable

The standard output cables of Raycus RFL-C2000S-HP/RFL-C3000S-HP/RFL-C4000S-HP/RFL-C6000S-HP fiber lasers are QBH output cables. The specific appearance dimensions are shown in Figure 3 below:

Compared with other types of laser output cable, there are differences in the size of the protective end cap. The protective end cap of this type is lengthened.

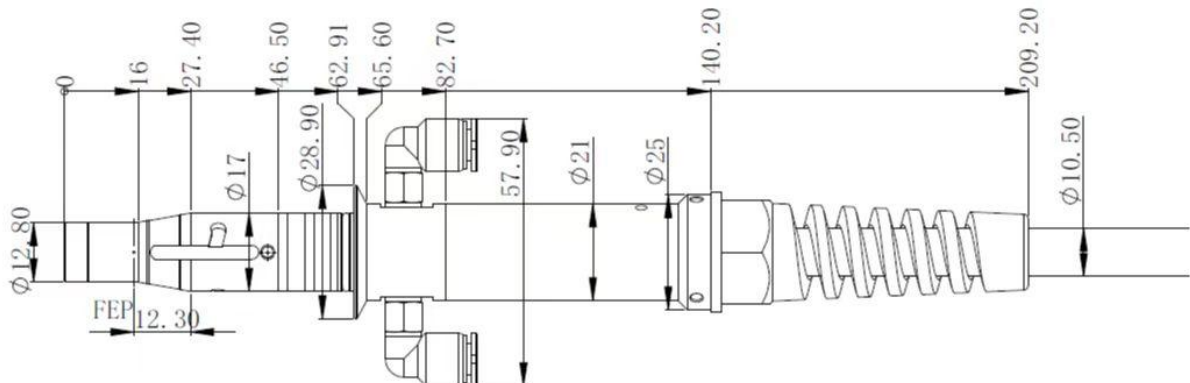



Figure 3 Dimensional drawing of QBH output optical cable (unit: mm)

	<ul style="list-style-type: none"> <li>◆ Before installing the output cable in the processing head, the lens of the output cable must be inspected. If the lens is dirty, it must be cleaned.</li> <li>◆ It is forbidden to disassemble the output lens by anyone other than Raycus, otherwise the warranty will be invalid.</li> <li>◆ Before the laser is used, it is necessary to ensure that the two copper rings of the output cable are fitted with the cutting head to form a short connection state.</li> </ul>
---	---

### 3.3 Cooling system installation and requirements

Table 5 Cooling system requirements

RFL-C2000S-HP /RFL-C3000S-HP /RFL-C4000S-HP/RFL-C6000S-HP

<b>Model</b>	<b>RFL-C2000S-HP</b>	<b>RFL-C3000S-HP</b>	<b>RFL-C4000S-HP</b>	<b>RFL-C6000S-HP</b>
Cooling capacity W	>5000	>7500	>10000	>15000
Minimum flow rate L/min	36		40	52
Max. input pressure Bar	7			
Water pipe size inner diameter mm	25			
Cooling system water temperature (°C)	22±1			

- a) Cooling system water temperature setting: 22±1°C
- b) Coolant requirements:
  - 1) The cooling water is pure water and it is recommended that pure drinking water can be used.
  - 2) To prevent the growth of mould in the water in the chiller leading to blocked pipes, it is recommended to add ethanol at a volume ratio of 10% when refilling with pure water.
  - 3) When the ambient temperature around the equipment is between -10° C and 0° C, an ethanol solution with a volume ratio of 30% must be used and changed every two months.
  - 4) When the ambient temperature around the equipment is below -10° C, a dual system (with heating function at the same time) chiller must be used and the cooling system must be guaranteed to run uninterrupted.
- c) Output fiber optic cable water cooling requirements:
  - 1) Water cooling flow: 1.7-2.0L/min。
  - 2) Water cooling pressure: Water inlet less than 0.6Mpa.
  - 3) Type of inlet and outlet fittings: SMC MS-5H-6.
  - 4) Type of water pipe: Outer diameter 6, inner diameter 4.
  - 5) Cooling water direction: unidirectional, connected to the water pipe in strict accordance with the inlet and outlet directions marked on the housing.
  - 6) Cooling water quality: deionized water, distilled water, pure water.
  - 7) Cooling water PH value: 5.5-9.

RFL-C2000S-HP /RFL-C3000S-HP /RFL-C4000S-HP/RFL-C6000S-HP

- 8) The water cooler needs to be equipped with a filter cartridge with a particle size of less than 100um.
  - 9) Maximum cooling water temperature: 45° C.
  - 10) Minimum cooling water temperature: greater than 5° C above the saturation dew point temperature.
  - 11) Additives in cooling water: meet the above PH and solid particle size requirements.
  - 12) Bending radius of the armoured tube: In non-working conditions such as transport and storage, the minimum bending diameter shall not be less than 30cm. In the laser outgoing condition, the minimum bending diameter shall not be less than 40cm.
  - 13) Long-term vibration, less than 2G; shock, less than 10G.
- d) Other requirements for cooling systems:
- 1) When first starting up the cooling system, the entire water system and joints should be checked for leaks. The external water pipes must be installed and connected according to the water inlet (IN) and water outlet (OUT) marked on the laser, otherwise the laser may not work properly.
  - 2) The laser should be emptied of cooling water inside the cooling system and inside the laser if it is not used for a long time, otherwise it will cause irrecoverable damage to the laser.

	<ul style="list-style-type: none"><li>◆ Please set the water temperature of the cooling system correctly. A high water temperature setting will result in the laser not working properly and a low water temperature setting will result in condensation inside the laser or on the laser output cable, which will cause irreversible damage to the laser.</li><li>◆ Please clean the water inlet filter assembly promptly. A blockage in the water inlet filter assembly will trigger a laser flow alarm or high temperature alarm.</li></ul>
---	--

	<ul style="list-style-type: none"><li>◆ Before switching on the laser, it must be ensured that the cooling system is working properly and that the water temperature is at a suitable temperature. [ Water temperature setting: <math>22 \pm 1^{\circ}\text{C}</math> ]</li></ul>
---	---

### 3.4 Installation considerations

- a) Place the laser horizontally in a suitable position and make the necessary fixings.
- b) Before powering up the laser, please check that the laser power supply voltage is stable (see Table 4 for laser models and corresponding power supply voltages) and that the grounding wire is good.
- c) Connect all the power cables of the laser as well as the control cables in an unpowered state.
- d) Connect the cooling system to the laser and the output fiber optic cable according to the inlet and outlet water markings.
- e) Please check the laser output head and clean it as necessary before installing it into the unit. If you find any dust or foreign objects on the laser output head that cannot be cleaned, please contact RESET in good time and do not proceed with the installation or operation of the laser for the time being.
- f) Do not step on, squeeze or excessively bend the yellow/metallic armoured protective sleeve during installation of the output cable to avoid damage to the fiber.
- g) During installation and disassembly, please take care to handle the laser output cable gently and do not subject it to vibration.
- h) During the installation of the laser output cable and output head, ensure that the surrounding environment is clean, otherwise the output head may be contaminated (do not use fans to avoid raising dust).
- i) The minimum bending diameter of the laser output cable should not be less than 30cm in the non-working state such as transportation and storage, and 40cm in the outgoing state.

	<ul style="list-style-type: none"><li>◆ All control cable connections to the laser should be made in a non-energised state; installing control cables with electricity may cause damage to the laser.</li></ul>
---	---

	<ul style="list-style-type: none"><li>◆ The laser output cable must be placed in as natural a state as possible and it is forbidden to twist the output cable.</li><li>◆ Too small a coiled diameter of the output fiber optic cable can lead to damage to the laser.</li></ul>
---	---

RFL-C2000S-HP /RFL-C3000S-HP /RFL-C4000S-HP/RFL-C6000S-HP

	<ul style="list-style-type: none"><li>◆ The lens and cutting head cavity must be clean and free of contamination before the laser output optical cable is assembled.</li><li>◆ Keep the protective cap on the output head in a safe place to prevent it from being contaminated; otherwise indirect contamination of the output head will occur when the cap is closed.</li></ul>
---	---

## 4 Guiding

---

---



**Please use the new version of the Raycus software and the instruction manual for the Raycus software.**

---

---

### 4.1 Front panel

Figure 4 shows the front panel style of the RFL-C2000S-HP/RFL-C3000S-HP/RFL-C4000S-HP/RFL-C6000S-HP laser (take C6000S as an example):

RFL-C2000S-HP /RFL-C3000S-HP /RFL-C4000S-HP/RFL-C6000S-HP

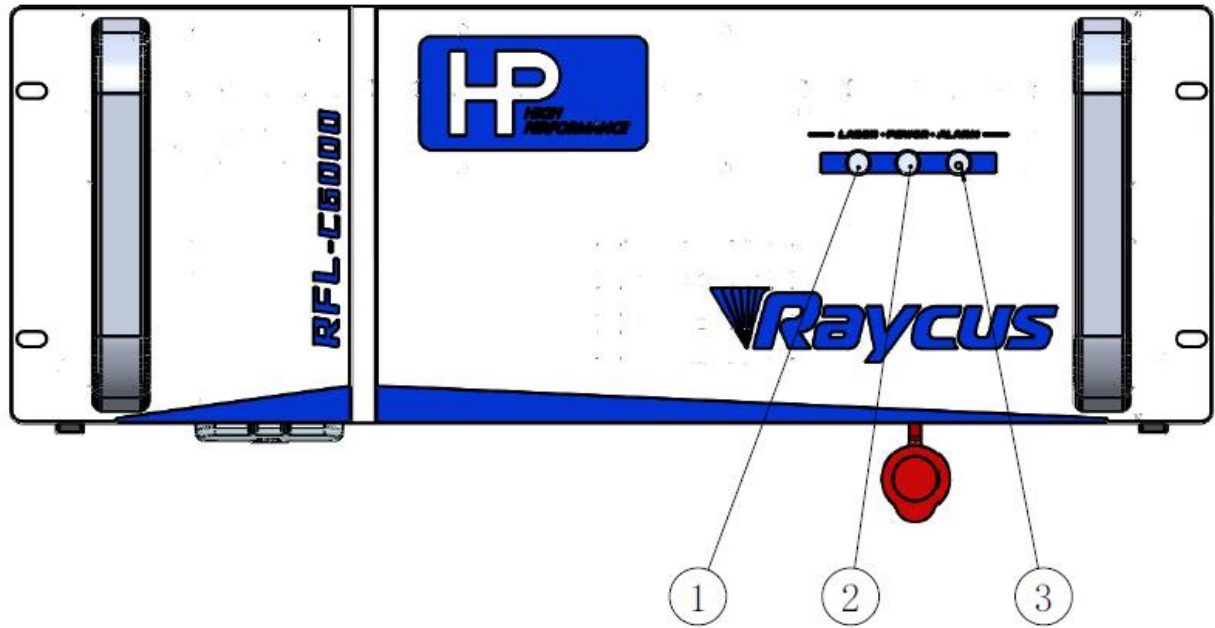

Figure 4 Front Panel of RFL-C6000S-HP fiber laser

- ① **LASER:** Emission indicator, laser out light Laser red light on.
- ② **POWER:** Control power indicator, white light indicates that the control system is on.
- ③ **ALARM:** Alarm indication, when the yellow light is on it means that an alarm has occurred on the machine.

## 4.2 Rear Panel

Figure 5 Rear Panel of RFL-C2000S-HP/ RFL-C3000S-HP/ RFL-C4000S-HP/ RFL-C6000S-HP Fiber laser (take C6000S as an example) :

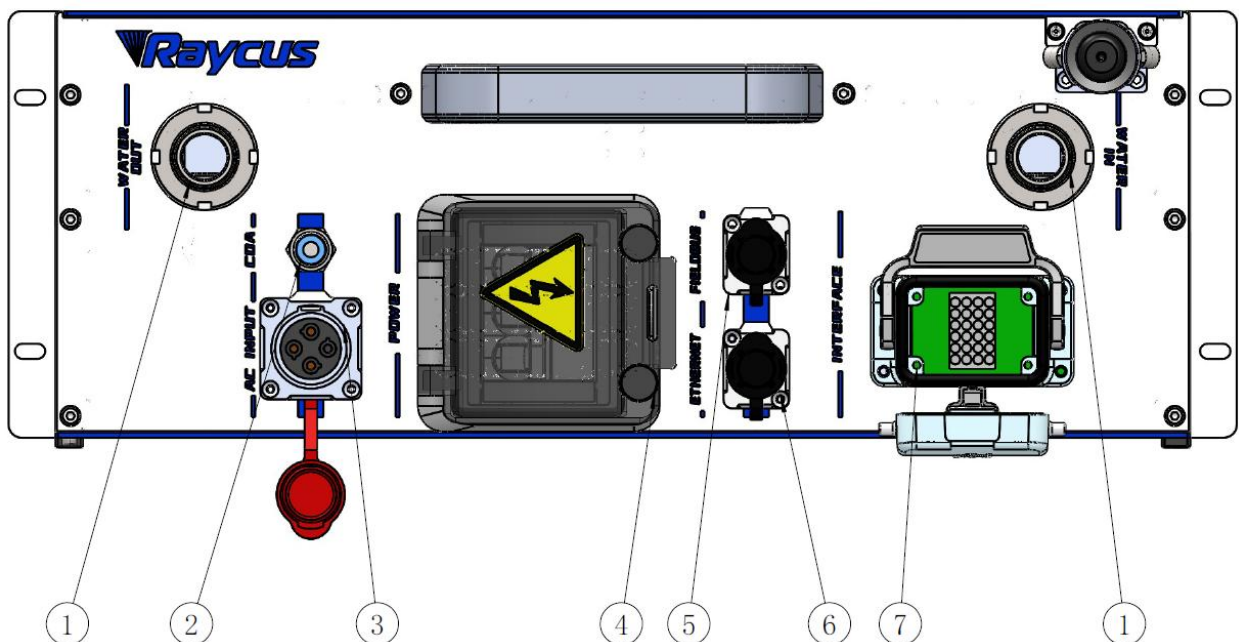

Figure 5 Rear Panel of RFL-C6000S-HP Fiber laser

① **WATER:** The water pipe interface, inlet and outlet are connected to the inflow and outflow of cooling water respectively, please connect this interface to the PU pipe of the corresponding outer diameter size according to the laser model (see Table 5 for laser model and corresponding water pipe size).

② **CDA :** Clean and dry air connection for access to clean and dry air to prevent condensation on the laser.

③ **AC INPUT :** The power input socket must be connected to the corresponding input voltage according to the laser model (see Table 4 for laser model and corresponding input voltage), and the matching plug provided by Roca must be used.

④ **POWER:** Air switch to control the on/off of AC power.

⑤ **FIELDBUS:** Bus interface (reserved).

⑥ **ETHERNET:** Ethernet interface. Provides remote control of the laser and storage of alarm information.

⑦ **CTRL-INTERFACE:**Control interface, CTRL-INTERFACE interface (24-pin), multi-functional multiplex port, which allows the user to set the control mode, input the analogue voltage signal, modulate the 24 V signal and is also the alarm signal output interface.

How to use the CDA:

- a) When using a CDA, the CDA should be dried and cooled by a chiller and filtered by a 5um and 0.3um particle filter and a 0.1um oil mist filter, respectively, at a temperature in the range of 5-40°C, with a maximum dew point of 0°C (it is recommended that the compressed air temperature be 5°C below the cooling water temperature), an air pressure of less than 0.1 MPa, a flow rate setting of 10 LPM and a connection pipe diameter of 6 mm.
- b) When using CDA filter components supplied by Roca, the incoming compressed air is to be dried and cooled by a chiller with an air pressure of less than 0.8 MPa and a connection tube diameter of 6 mm.
- c) Ventilation must be started 30 minutes before the start of the machine, but in winter, when the temperature is below 10°C and the humidity is below 50%, ventilation may not be used.

RFL-C2000S-HP /RFL-C3000S-HP /RFL-C4000S-HP/RFL-C6000S-HP

### 4.3 Power connections



	<p>◆ Before connecting AC power, verify that the laser model and the supplied AC power supply are the same as those listed in Table 2 or Table 4.</p>
---	---

Table 6 Power connection requirements

Model	RFL-C2000S-HP	RFL-C3000S-HP	RFL-C4000S-HP	RFL-C6000S-HP
Power Supply	360~510VAC50/60Hz			
Power Cable				
End of Cable	Four strands of wire, diameter 4 mm <sup>2</sup> , Labelled L1, L2, L3 and PE			
Descriptions	L1, L2, L3->Phase line PE->Protective earth wire			
Remarks	The plug at the end of the power cord is inserted into the socket marked "AC INPUT" on the rear panel. Note that this plug has an anti-reversal function and that it is locked with the latch after insertion.			

### 4.4 Control interface definition and connection

#### 4.4.1 Control interface definition

Control is carried out using the CTRL-INTERFACE interface (24-pin), which is defined as follows:

RFL-C2000S-HP /RFL-C3000S-HP /RFL-C4000S-HP/RFL-C6000S-HP

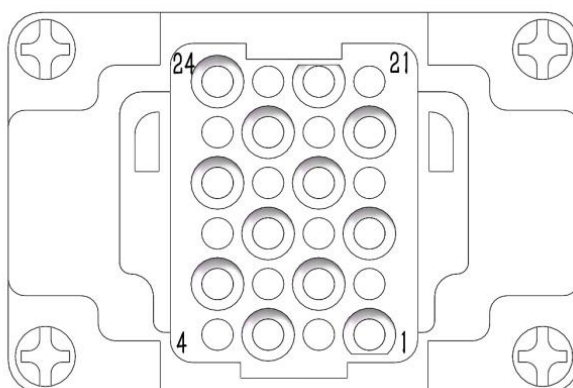

Figure 6 CTRL-INTERFACE Schematic

Table 7 Definition of the 24-pin interface for laser control

Pin	Signal Name	Signal Type	Signal Level	Signal Drive	Typical Response Time	Description
1	Interlock Ch1A	Contact Closure Input	24Vdc	0.1A	<500ms	According to "EN954-1" or "ISO13849-1 Cat.3PLd". Passive contact, not to be connected to external voltage or earth.
2	Interlock Ch2A					
3	Interlock Ch2B					
4	Interlock Ch1B					
5	RS232Tx	---	---	---	120ms	Transmit Data
6	RS232Rx	---	---	---		Receive Data
7	RS232Com	Return	---	---		RS-232 Return
8	Remote Key Switch	Contact Closure Input	24Vdc	>1A (Contact s and cables)	20s	Starts the internal main control board power supply. Passive contact, not to be connected to external voltage or earth.
9						
10	Remote Start Button	Contact Closure Input	24Vdc	10mA	1s	Start the internal main power supply. Passive contact, no external voltage or earth connection.
11						
12	Analog Input to control	Analog Input	1-10 Vdc	1 mA	100μs	Current setting analog inputs. 1-10VDC = 10-100% current.
13	Analog Output Power Monitor	Analog output	0-8.0 Vdc	11mA	20μs	Analog output 0-8VDC=0-Pnom
14	Isolated Analog Com	Return	---	---	---	Return for signals on pins 12, 13
15	Modulation+	Digital	5-	6 mA	20μs	5-24VDC Input

		Input	24Vdc			
16	Modulation-	Return	---	---	---	Return for signal on pin 15
17	Guide Control	Digital Input	5- 24 Vdc	6 mA	120ms	Positive edge turns On red guide laser in Guidelaser external control mode
18	Emission Enable	Digital Input	5- 24Vdc	6 mA	120ms	Positive edge activates emission in external enable mode
19	Laser Error	Digital Output	24Vdc	100mA	120ms	High indicates a laser error status
20	System Common	Return	---	---	---	Return for signals on pins 17-19, 21-24
21	Error reset	Digital Input	5-24V dc	6 mA	120ms	Positive edge resets all resettable errors
22	Laser ready	Digital Output	24Vdc	100mA	120ms	High indicates laser is ready
23	Main power on	Digital Output	24Vdc	100mA	120ms	High indicates Main powered on
24	Emission ON	Digital Output	24Vdc	100mA	100us	High indicates laser is emitting



◆ Please check the level of the control signal to ensure that it meets the requirements. The laser may be damaged if the voltage exceeds or fluctuates.

The Interlock interface is 24 pin, pin 1 and 4, 2 and 3. If these two pins are disconnected, the laser will interrupt the output of light immediately, the laser Ready signal output will become low, and the laser will display Interlock abnormality.

When one of the Interlock channels is open circuited, it is impossible to start the main laser power supply until the other Interlock channel is also open circuited, and then close both channels before starting the main laser power supply.

For safety, pins 10 and 11 of the control interface cannot be shorted at the same time or in advance with pins 8 and 9, the control system inside the laser starts to detect the rising edge of pins 10 and 11 and executes the power on command of the main power supply after the power on operation self-test is completed.

RFL-C2000S-HP /RFL-C3000S-HP /RFL-C4000S-HP/RFL-C6000S-HP

	<ul style="list-style-type: none"> <li>◆ The Interlock interface shall not be connected to the active signal, otherwise the interface will be damaged and the laser will alarm;</li> <li>◆ After all interlocks are closed, short circuit CTRL INTERFACEpin10 and 11for more than 0.5s, and power on the main power supply; If any Interlock is disconnected, the main power supply will be turned off immediately;</li> <li>◆ After the main power supply is disconnected, wait at least 10s before re shorting CTRL INTERFACEpin 10 and 11.</li> </ul>
---	--

#### 4.4.2 Ethernet TCP/IP interface settings

Table 8 Definition of Ethernet interface pins

Pin	Function	Description
1	TX+	Data transmission+
2	TX-	Data transmission-
3	RX+	Data reception+
4	N/C	Noconnection
5	N/C	Noconnection
6	RX-	Data reception-
7	N/C	Noconnection
8	N/C	Noconnection

If conditions permit, please give priority to this interface to obtain better communication stability. The laser and computer must be in the same LAN.

Table9 LaserIP address

LaserdefaultIPaddress	
IP address	192.168.0.10
Subnetmask	255.255.255.0

IPconfiguration:

- a) Open “Local Area Connection” on your PC, and then click “Properties” ;
- b) Select “Internet Protocol Version 4” (TCP/IP 4);
- c) Click “Properties” button;
- d) Select "Use the following IP address:" to manually assign IP addresses;
- e) Assign an IP address of 192.168.0. x (x cannot be 10, because 192.168.0.10 has been assigned to the laser), and then assign a subnetmask address, which is 255.255.255.0 by default;
- f) Click “OK” to confirm the settings and exit. See Figure 7 for details.

RFL-C2000S-HP /RFL-C3000S-HP /RFL-C4000S-HP/RFL-C6000S-HP

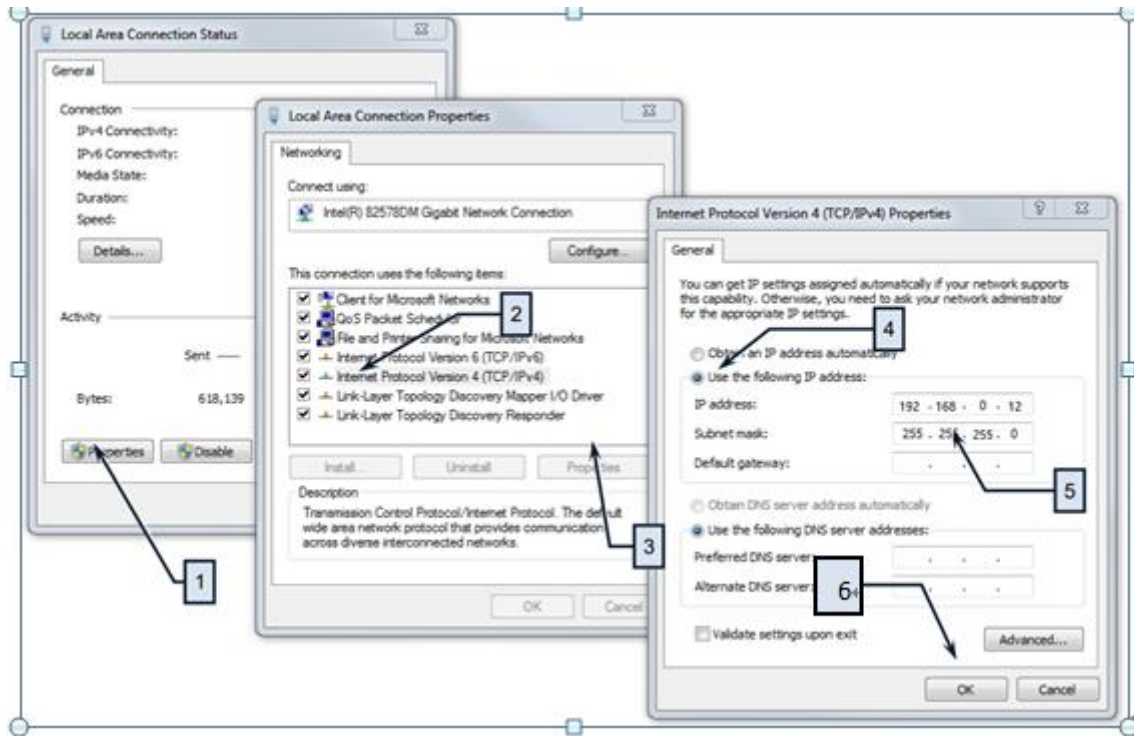

Figure 7 IP Settings on PC Side

After the IP setting is completed, open the Raycus software, and the connection status in the corresponding text box on the Raycus software menu shows: connected, indicating that the micro-controller program runs normally and the communication connection is normal. The display menu is shown in below Figure 8.

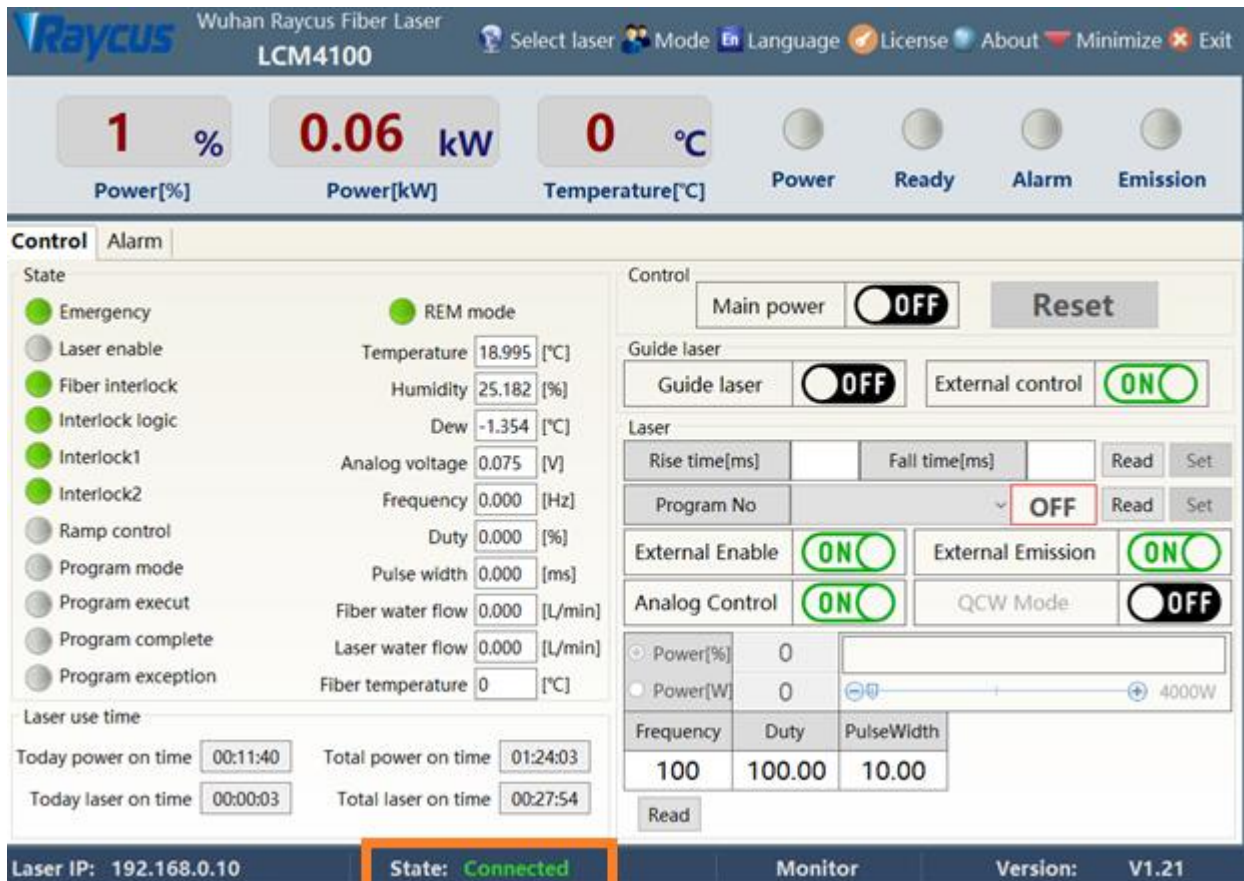

Figure 8 Main menu of normal communication connection

### 4.4.3 RS232 and INTERNET communication command

#### 4.4.3.1 Port configuration

RS-232 configuration as below:

Baud rate: 9600, data bit: 8, stop bit: 1, no parity bit and no flowcontrol.

Ethernet port configuration as below:

Laser default IP address: 192.168.0.10

Laser TCP port: 10001

Laser UDP port: 8099

#### 4.4.3.2 Laser communication protocol (network port & serial port)

All commands and return values in this protocol are composed of ASCII characters. The following points should be noted when entering:

- The command is generally composed of 3 or 4 letters, sometimes with additional values.
- All commands and return values end with a carriage return character (CR, 0x0D, \r). If

RFL-C2000S-HP /RFL-C3000S-HP /RFL-C4000S-HP/RFL-C6000S-HP

the product receives a string with a "carriage return" character, but the command is invalid, it will return "BCMD\r".

- c) For easy identification, all commands are uppercase letters, but in fact, this product does not distinguish between uppercase and lowercase letters. To facilitate identification, a space is added between the command and the parameter.
- d) The product will send a return value for each command received. The return value generally contains the command content itself. If the returned content contains numeric values or error types, ":" will be used to separate the returned command content from numeric values or error types.

Please see table 10 for specific agreement contents and command examples.

Table 10 Specific Agreement Contents and Command Examples of Laser

Command	Description	Command Example
ABF	Aiming Beam OFF –Turn off red beam	Send: "ABF\r" Return: "ABF\r"
ABN	Aiming Beam ON – Turn on red beam	Send: "ABN\r" Return: "ABN\r"
DEABC	Disable External Aiming Beam Control –Turn off the external red beam control	Send: "DEABC\r" Return: "DEABC\r"
EEABC	Enable External Aiming Beam Control – Switch to external red beam control	Send: "EEABC\r" Return: "EEABC\r"
DEC	Disable External Control – Turn off AD control mode	Send: "DEC\r" Return: "DEC\r"
EEC	Enable External Control – Switch to AD control mode	Send: "EEC\r" Return: "EEC\r"
DLE	Disable Hardware Emission Control –Forbid to enable the laser from the control interface	Send: "DLE\r" Return: "DLE\r"
ELE	Enable Hardware Emission Control – Allow to enable the laser from the control interface	Send: "ELE\r" Return: "ELE\r"
DGM	Disable Gate Mode – Turn off external modulation mode	Send: "DGM" Return: "DGM"
EGM	Enable Gate Mode – Turn on external modulation mode	Send: "EGM" Return: "EGM"
EMOFF	Stop Emission –Turn off the laser (or disable it )	Send: "EMOFF\r" Return: "EMOFF\r"

EMON	Start Emission – Turn on the laser (or enable it)	Send: “EMON\r” Return: “EMON\r”
MPWROFF	Main Power OFF – Turn off the main power	Send: “MPWROFF\r” Return: “MPWROFF\r”
MPWRON	Main Power ON – Turn on the main power	Send: “MPWRON\r” Return: “MPWRON\r”
SPW	Set Pulse Width	Send: “SPW 100\r” Return: “SPW: 100\r” (Setpulsewidth100ms) Other return value: “ERR: input Err\r” (input pulse width<0.0001) “ERR: Out of Range\r” (Exceeds the maximum pulse width range) “ERR: Duty Cycle too High\r”(The set of duty cycle too high) “ERR: Duty Cycle too Low\r”(Set pulse width <0.02) “SPW: 100,Duty=100%\r”
SPRR	Set Pulse Repetition Rate	Send: “SPRR 1000\r” Return: “SPRR: 1000\r” Other return value: “ERR: input Err\r” (Input frequency <0) “ERR: Out of Range\r” (Exceeds the maximum pulse width range) “ERR: Duty Cycle too High\r”(The set of duty cycle too high) “ERR: Duty Cycle too Low\r”(Set pulse width <0.02) “SPW: 100,Duty=100%\r”
SDC	Set Diode Current – Set the operating current of the optical module (unit:%).The setting value must be lower than 100% and higher than the minimum current setting value, which can be set to 0. If the set value is bigger than 100, the default is input 100.	Send: “SDC 100\r” Return: “SDC: 100\r” Otherreturn value: “ERR: Input Err\r” (input value <0) “Laser is worked in AD Mode\r” (Working in external AD mode, the command is invalid)
RCS	Read Current Setpoint	Send: “RCS\r” Return: “RCS: 56.7\r” (Present current setting value is 56.7%)

RPRR	Read Pulse Repetition Rate	Send: "RPRR\r" Return: "RPRR: 10\r" (Pulse Repetition Rate 10Hz)
RBT	Read Board Temperature	Send: "RBT\r" Return: "RBT: 36.6\r"
RPW	Read Pulse Width	Send: "RPW\r" Return: "RPW: 5.5\r" (Pulse Width is 5.5ms)
RCT	Read Laser Temperature	Send: "RCT\r" Return: "RCT: 34.5\r"
ROP	Read Output Power – Reads the output power in watts.	Send: "ROP\r" Return: "ROP: 4000.4\r"
RSN	Read Serial Number – Reads the serial number of the device.	Sent: "RSN" Return: "RSN:221200251\r"
PERR	Reset Errors –Clear internal errors	Send: "PERR\r" Return: "PERR\r"
RIP	Read IP – Read the current IP address	Send: "RIP\r" Return: "RIP: 192.168.0.10\r"
RMASK	Read Sub-net Mask – Read the current sub-net mask address	Send: "RMASK\r" Return: "RMASK: 255.255.255.0\r"
SIP	Set IP – Set LaserIP	Send: "SIP 192.168.0.10\r" Return: "SIP: 192.168.0.10\r"
SMASK	Set Sub-net Mask – To set the sub-net mask, append a string of decimal digits with "."	Send: "SMASK 255.255.255.0\r" Return: "SMASK: 255.255.255.0\r"
SIP	Set IP – To set the IP address, you need to attach a string of decimal digits with "."	Send: "SIP 10.0.0.231\r" Return: "SIP: 10.0.0.231\r"
SUT	Set Up Time – Set power rise time (unit: ms)	Send: "SUT 50\r" Return: "SUT: 50\r"
SDT	Set Down Time – Set power drop time (unit: ms)	Send: "SDT 50\r" Return: "SDT: 50\r"
RUT	Read Up Time – Read power rise time (unit: ms)	Send: "RUT \r" Return: "RUT: 50\r"
RDT	Read Down Time – Read power drop time (unit: ms)	Send: "RDT \r" Return: "RDT: 50\r"
PSRT	Program Start	Send: "PSRT 1\r" Return: "PSRT: 1\r"
PSTP	Program Stop	Send: "PSTP\r" Return: "PSTP\r"

RFL-C2000S-HP /RFL-C3000S-HP /RFL-C4000S-HP/RFL-C6000S-HP

Other	Commanderror	Send: "BGM\r" Return: "BCMD\r"	
STA	Read device status – Read the product status. The return value is 32Bit digital information. The meanings of each bit are as follows (undefined or "reserved" bits can be ignored):		
	Bit 0	0-Normal operation 1-Authorization time	
	Bit 1	0-Normal 1-Overheat	
	Bit 2	0-Laser not enabled 1-Laser enabled	
	Bit 3	0-Back Reflection OK 1-High Back Reflection Level	
	Bit 4	0-External AD mode=off 1-External AD mode=ON	
	Bit 5	Reserved Reserved	
	Bit 6	0-Normal 1-Slave communication abnormal	
	Bit 7	Reserved Reserved	
	Bit 8	0-Aiming Beam OFF 1-Aiming Beam ON	
	Bit 9	0-Laser not ready 1-Laser ready	
	Bit 10	0-QCW mode=off 1-QCW mode=on	
	Bit 11	0-main power supply=OFF 1-main power supply=ON	
	Bit 12	0-Modulation Disabled 1-Modulation Enabled	
	Bit 13	Reserved Reserved	
	Bit 14	Reserved Reserved	
	Bit 15	0-Laser does not emit beam	
			Send: "STA" Return: "STA: 4100" The return value 4100 (decimal) can be converted to 0x1004 (hexadecimal), and then converted to binary. It can be seen that Bits2 and 12 have been set. That means"Laser Enable" is turned on and "Modulation" mode is enabled

RFL-C2000S-HP /RFL-C3000S-HP /RFL-C4000S-HP/RFL-C6000S-HP

		1-The laser is emitting beam
Bit 16		0-Gate Mode Disabled
		1-Gate Mode Enabled
Bit 17		Reserved
		Reserved
Bit 18		0-External enable mode=off
		1-External enable mode=on
Bit 19		0-Normal
		1-Laser is Error
Bit 20		0-Slow rise and slow drop mode off
		1-Slow rise and slow drop mode ON
Bit 21		0-The laser operates in "ON"
		1-The laser operates in
Bit 22		0-Programming mode off
		1-Programming mode on
Bit 23		Reserved
		Reserved
Bit 24		0-Normal
		1-Low temperature fault
Bit 25		0-Normal
		1-Humidity alarm
Bit 26		0-Normal
		1-Flow alarm of water flow
Bit 27		0-Aimingbeam internal
		1-Aimingbeamexternal
Bit 28		0-Normal
		1-Flow alarm of water flow
Bit 29		0-Normal
		1-Critical Error
Bit 30		0-Optical Interlock OK
		1-Optical Interlock active
Bit 31		0-Normal
		1-Average power is too high

## 4.5 Laser installation sequence

- a) Take out the laser carefully and move it to the installation position;
- b) Remove the protective cap of the output cable head, and use strong light to check whether the lens at the output end has dust. If yes, please clean it before installation, and then cover the protective cap of the output head;
- c) Install the output cable on the processing equipment according to the actual situation (install the cooling water pipe of the output head at the same time), pay attention to sorting out the output optical cable, and protect the output head. Remove the protective cap, confirm whether the lens at the output end is clean again, and then install the output head;
- d) Connect the cooling system, water inlet filter assembly and laser cooling water pipe;
- e) Connect the control circuit and power supply according to the control mode.

## 4.6 Steps of Starting

- a) Make sure the air switch is OFF, all electrical connections must be finished before the laser is powered on;
- b) Short the 1/4, 2/3 pins of CTRL-INTERFACE;
- c) Turn on the chiller and check leakage. If there is no water leakage, turn off the chiller and wait for the laser to turn on;
- d) Turn on the air switch on the rear panel;
- e) Turn on the chiller;
- f) Short the 8/9 pins of CTRL-INTERFACE and start the laser.

## 4.7 Functions of Raycus software

The RFL-C2000S-HP/ RFL-C3000S-HP/ RFL-C4000S-HP/ RFL-C6000S-HP Raycus software communicates with the main control board through UDP when it is working. Through the background program running in the software and the human-computer interaction operation, the laser parameters are read and set and the control functions are realized. The menu displayed by the software is divided according to functional categories, including control, alarm, about, language selection, authorization, working mode selection and other pages.

### 4.7.1 The control menu

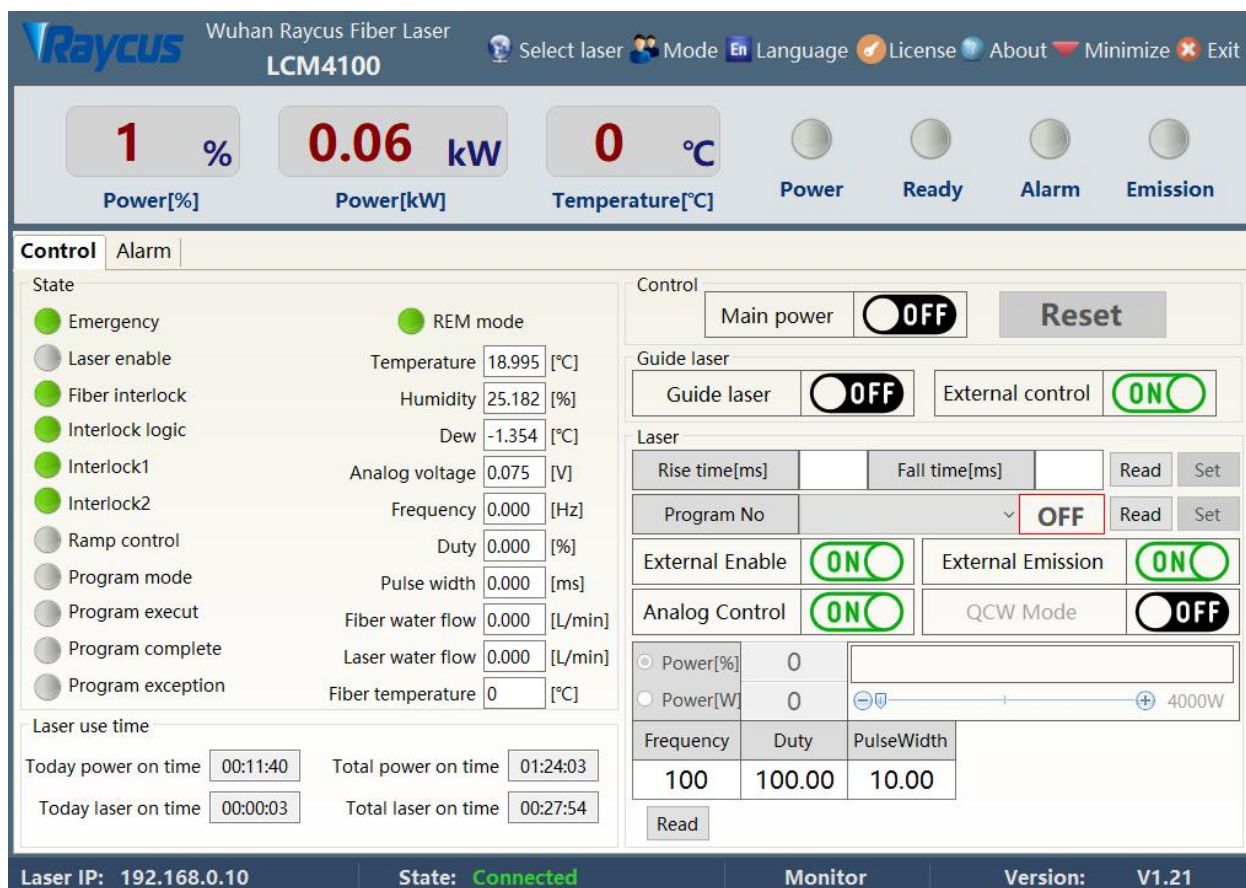

Figure 9 Raycus software control menu

Table 11 Description of the main status display area of the laser

Power [%]	display of the currently set power percentage
Power[kW]	display of the current average output power of the laser in kW
Temperature	display of the current water-cooled plate temperature of the laser, in degrees Celsius
Power indicator	Indicates the current status of the main power supply Green - main power is on Gray - main power is off
Ready indicator	Indicates the Ready status of the current laser Green - the laser is ready to emit laser beam Gray - the laser not ready
Alarm indicator	Indicates the current alarm state of the laser Yellow - the laser is abnormal Gray - the laser is not abnormal
Emission indicator	Indicates the current output state of the laser Red - the laser is outputting laser beam Gray - the laser is not outputting laser beam

RFL-C2000S-HP /RFL-C3000S-HP /RFL-C4000S-HP/RFL-C6000S-HP

Table 12 Description of laser working status display

Emergency	Red - indicates that the emergency stop button on the front panel of the laser is pressed Gray - Indicates that the emergency stop button on the front panel of the laser has been reset C3000S-C4000S-C6000S HP don't have this function
REM	Green - the laser works in REM mode Gray - the laser works in ON mode C3000S-C4000S-C6000S HP don't have this function
Laser Enable	Green - the laser is enabled Gray - the laser not enabled
Fiber Interlock	Green - The Interlock on output cable head is connected Gray - The Interlock on the output cable head is disconnected
Interlock1	Green - pins 1 and 4 on the control interface are connected Gray - pins 1 and 4 on the control interface are disconnected
Interlock2	Green - pins 2 and 3 on the control interface are connected Gray - pins 2 and 3 on the control interface are disconnected
Interlock Logic	Green - Interlock1& 2 meet logic requirements Gray - Interlock1& 2 do not meet logical requirements
Program Mode	Green - The laser is running in programming mode Gray - The laser is not running in programming mode
Ramp Control	Green - the laser is running in power ramp-up and ramp-down mode Gray - the laser is not running in power ramp-down mode
Programexecut	Program is executing
Programcomplete	Program execution complete
Programexception	Abnormal program execution

Table 13 Description of Control Area Icons

Main Power	Click ON, the main power is power on Click OFF, the main power is power off
Guide Laser	Click ON, turn on the red guide beam Click OFF, turn off the red guide beam
Guide Laser External Control	Click ON, turn on the 17-pin red guide beam control function Click OFF, turn off the 17-pin red guide beam control function Mode power off automatic memory
External Enable	Click ON,turn on the 18-pin enable function Click OFF, turn off the 18-pin enable function Mode power off automatic memory
Analog Control	Click ON, turn on the AD analog mode Click OFF, turn off the AD analog mode Mode power off automatic memory
External Emission	Click ON, turn on the 15-pin laser control function Click OFF, turn off the 15-pin laser control function
Reset	Clear the alarm of the current laser
Emission ON	Emit laser
Emission OFF	No emit laser



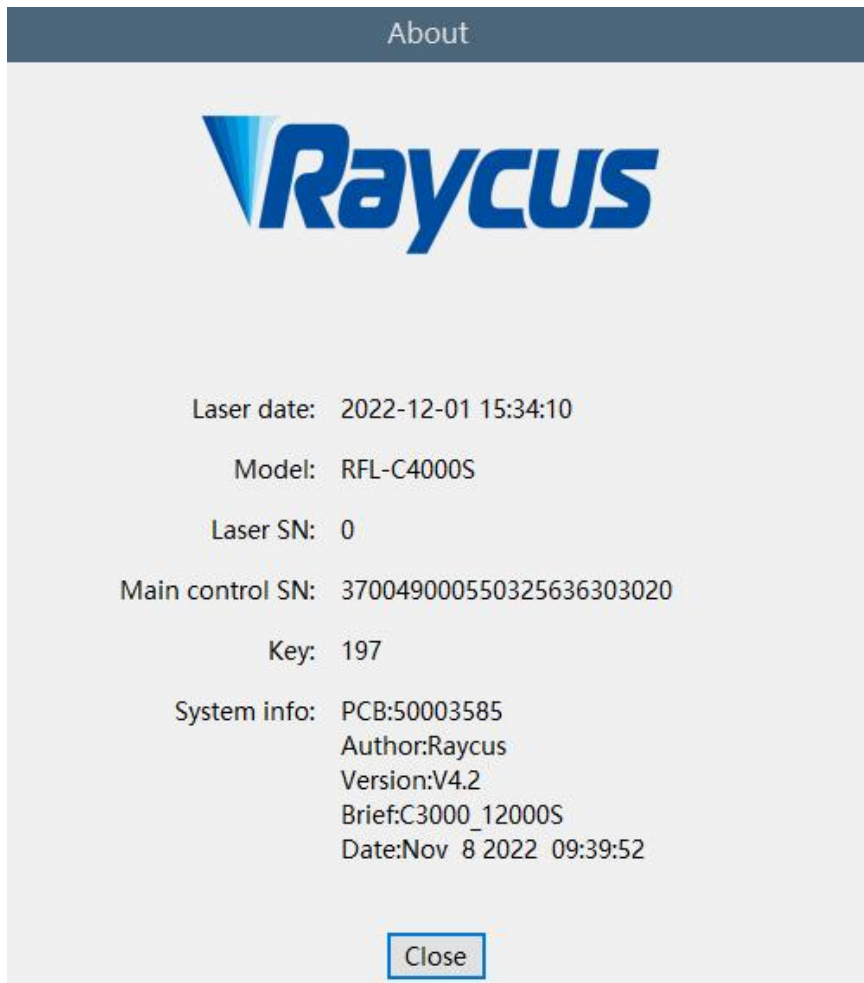

Figure 11 “About” menu

#### 4.7.4 Select language

In the language selection menu, you can set the language used by the software. After selecting the language and clicking OK, the software will automatically convert the content displayed in the software to the language without restarting the software. At the same time, the currently selected language will be saved to the configuration file. When you start the software next time displays in the last language set.

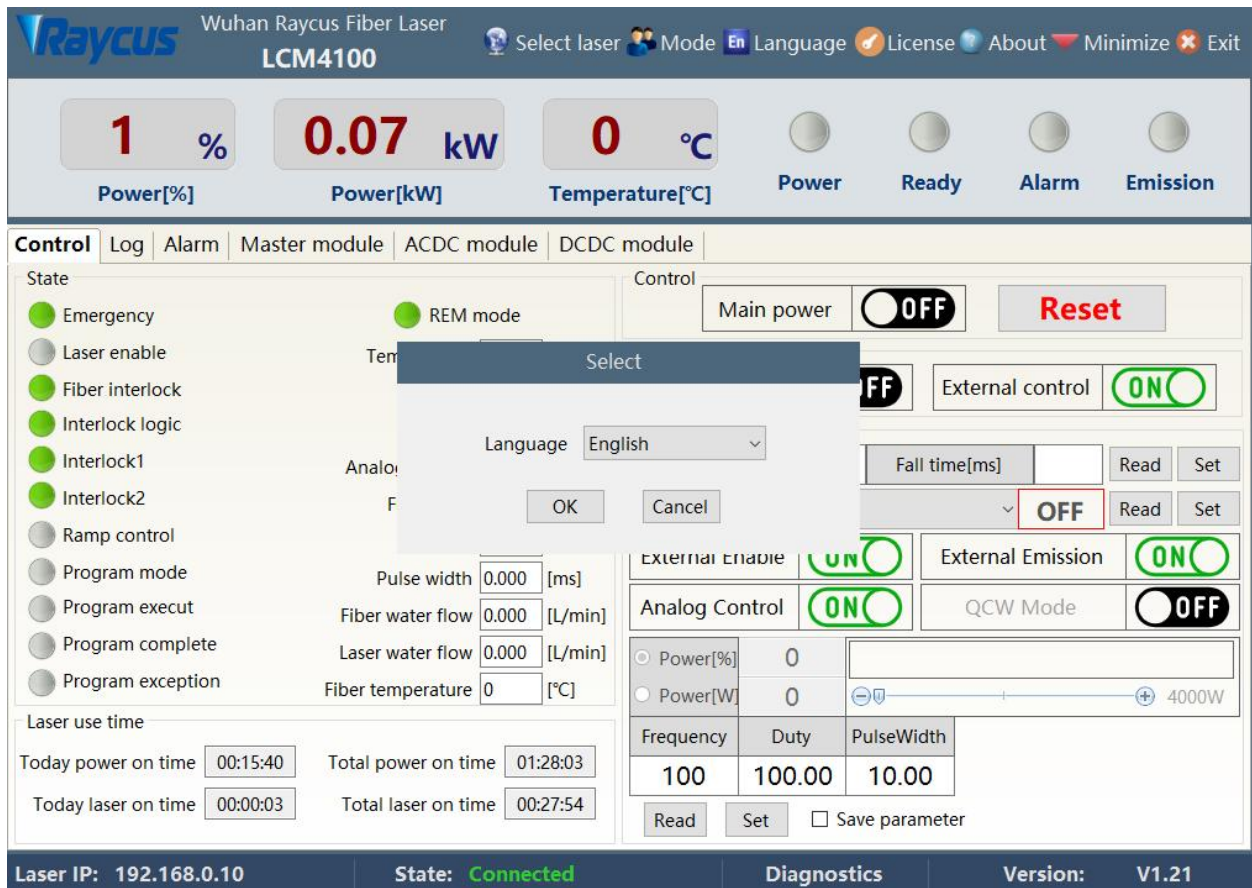

Figure 12 Select language menu

#### 4.7.5 Authorization

The authorization menus used to control the time-limited lock of the laser. When the authorization menus opened, the machine code, laser lock time and lock time are loaded once. The laser lock time is Raycus' time-limited lock for integrators, and the lock time is for integrators to end customers. time-limited lock. On the authorization menu, only the authorization code of Raycus can be set, and the function of calculating the authorization code is implemented in the server, which has nothing to do with the Raycus software. The authorization code used by the integrator can be generated in the authorization menu.

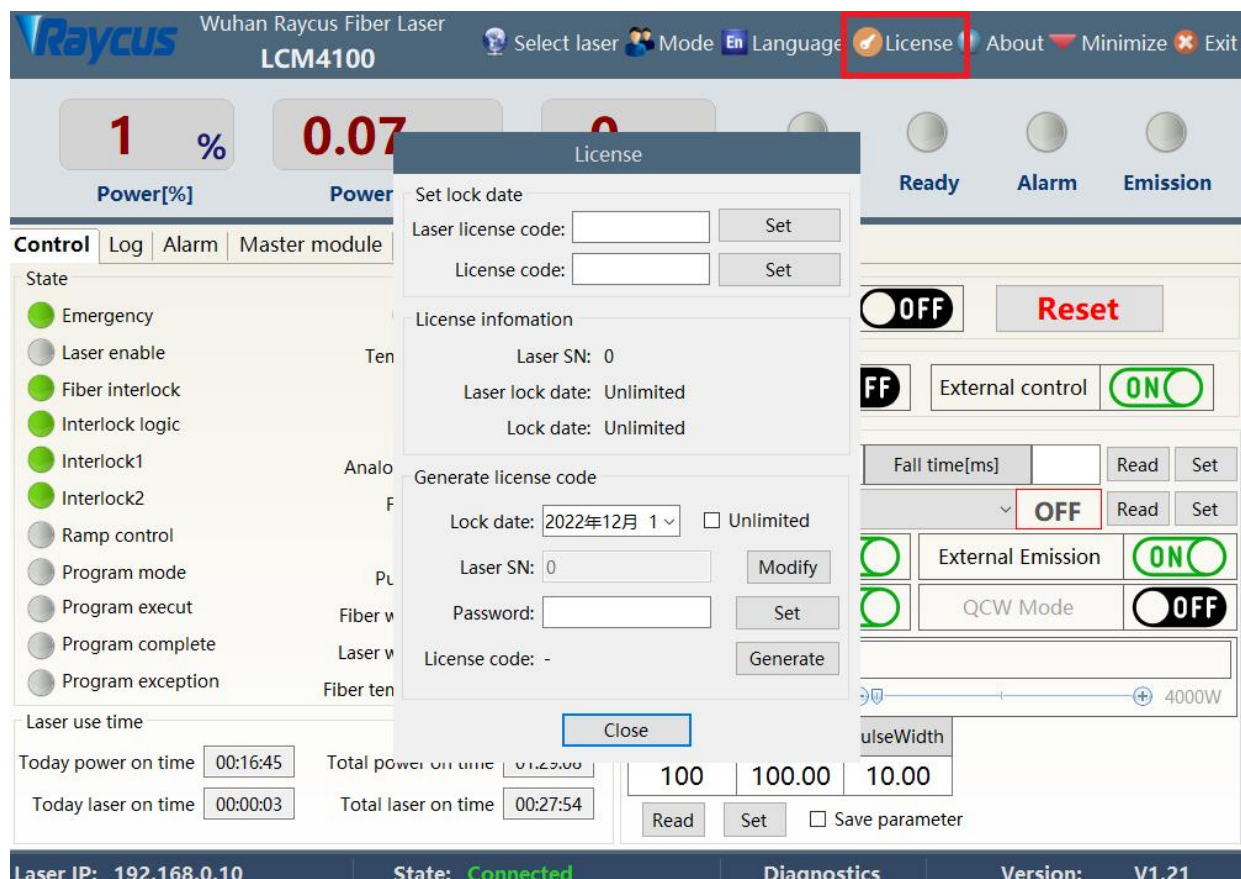

Figure 13 “Authorization”menu

#### 4.7.6 Mode Selection

Mode selection is used to select the mode of the current software, including observation mode, control mode, diagnosis mode and debugging mode.

Observation mode: When the software is opened, the observation mode is selected by default. The most commonly used and concerned information is displayed on the software menu. The observation mode can be used without a password.

Control mode: The control mode adds the function of the operable control menu on the basis of the observation mode. A password is required to enter the control mode. The initial password is 81338818 (the password can be modified).

Debugging mode: On the basis of the diagnostic mode, the debugging mode adds a parameter setting menu, an encryption mode that only Raycus engineers can enter.

Diagnosis mode: When the laser fails and needs to be diagnosed remotely, or the integrator needs to know more status information of the laser, it can enter the diagnosis mode. The diagnosis mode adds the status and alarm information of the main control module, slave control module, ACDC module and DCDC module on the basis of the observation mode. A password is

RFL-C2000S-HP /RFL-C3000S-HP /RFL-C4000S-HP/RFL-C6000S-HP

required to enter the diagnosis mode. The initial password is 81338818 (the password can be modified).

### 4.7.7 Master module

The Master module contains all the status, alarm and system parameters of the main control module, and the status and alarm information are automatically refreshed.

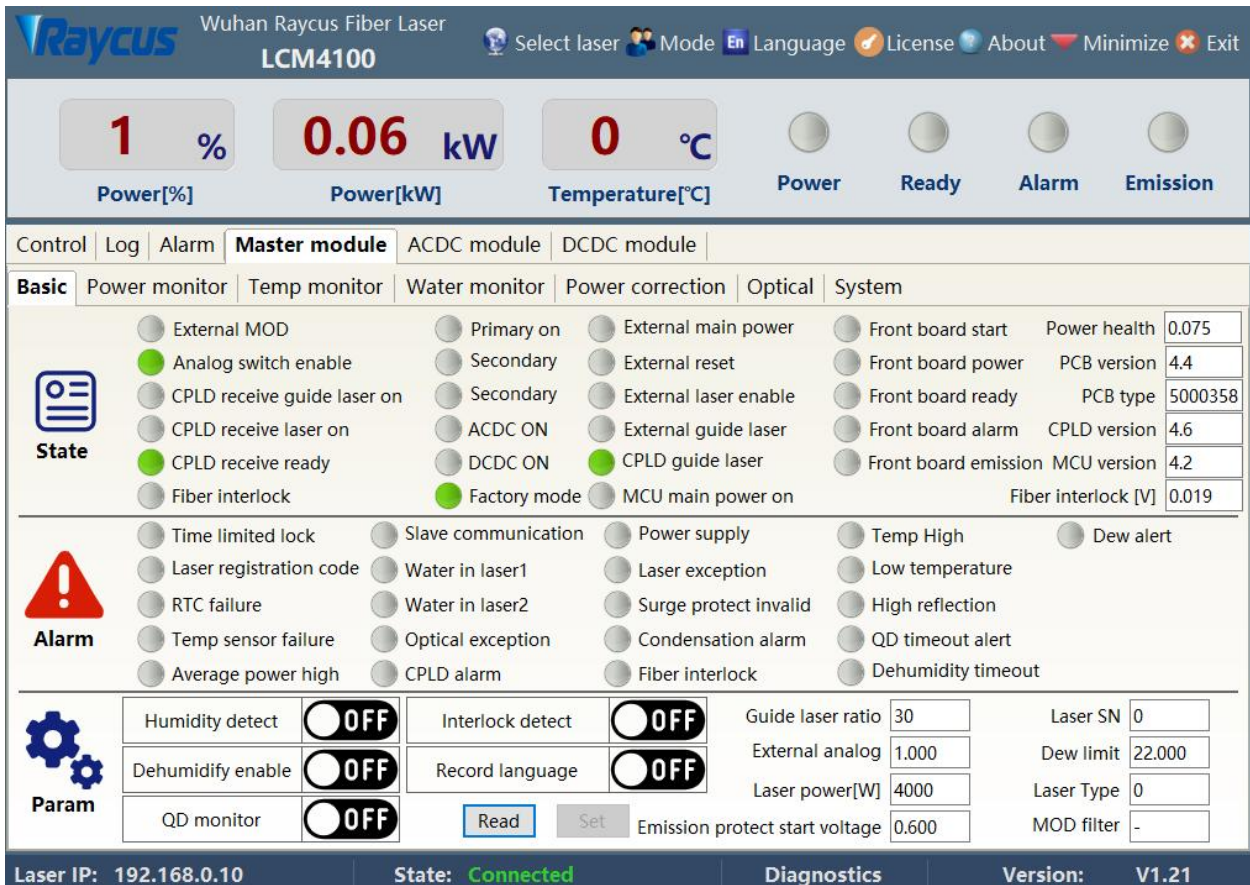

Figure 14 Main control module status information menu

Connect to the network through the main control module system parameter menu:

AP mode: the laser is a WiFi hot-spot (hot-spot name and password can be configured), after the mobile phone is connected to the laser WiFi hot-spot, you can use the Raycus mobile APP to view the real-time status of the laser;

STA mode: The laser can automatically connect to the mobile phone hot-spot or wireless router (the hot-spot name and password can be configured), the laser establishes a connection to Raycus' cloud server through WiFi, and sends real-time data, which can realize remote viewing and parameter setting functions.

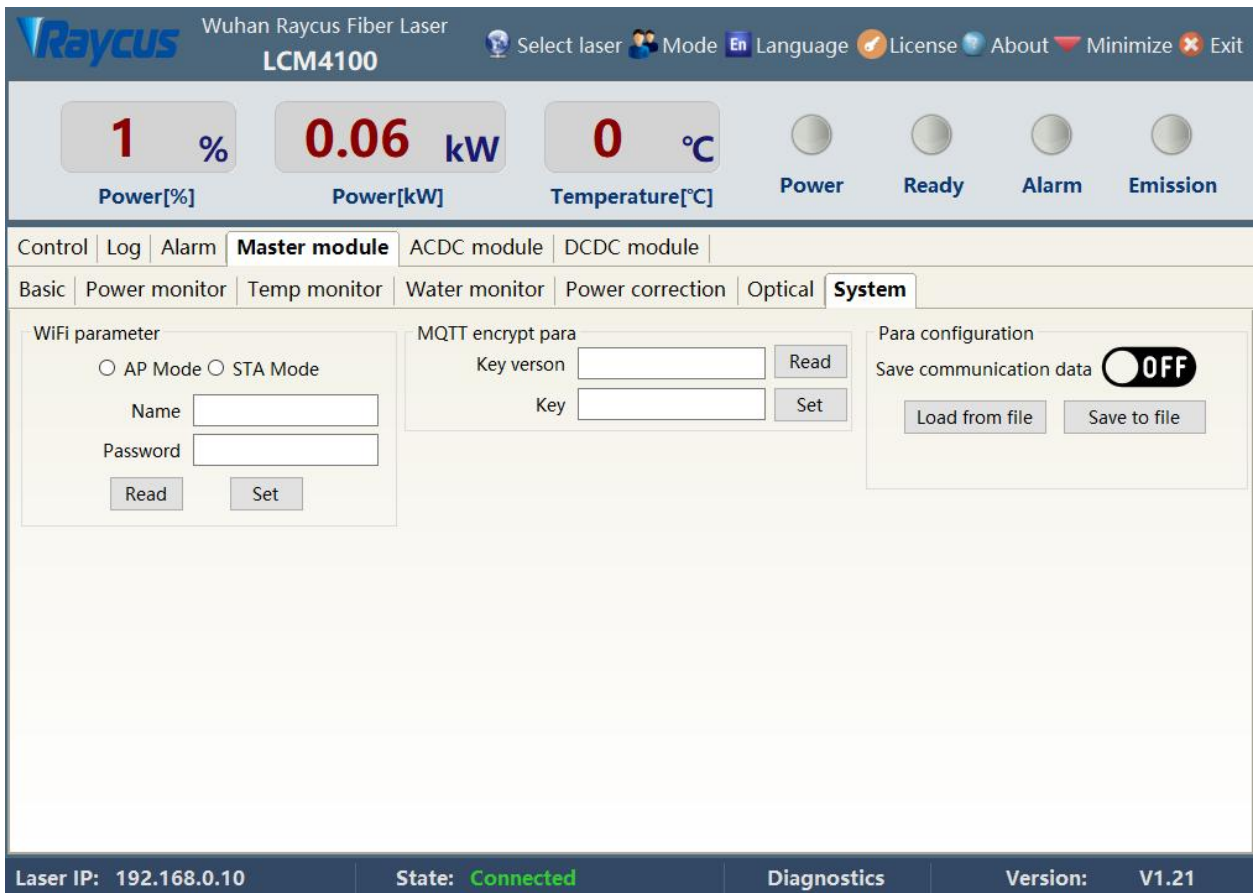

Figure 15 Main control module system parameter menu

#### 4.7.8 ACDC module

The ACDC module page contains the relevant status information of the ACDC module, and the refresh interval of the status information does not exceed 100ms.

RFL-C2000S-HP /RFL-C3000S-HP /RFL-C4000S-HP/RFL-C6000S-HP

Wuhan Raycus Fiber Laser  
LCM410

Select laser Mode En Language License About Minimize Exit

1 % Power[%]  
0.06 kW Power[kW]  
0 °C Temperature[°C]

Power Ready Alarm Emission

Control Log Alarm Master module **ACDC module** DCDC module

	ACDC1	ACDC2	ACDC3	ACDC4		ACDC1	ACDC2	ACDC3	ACDC4
ACDC Input	<input type="checkbox"/>	<input type="checkbox"/>	<input type="checkbox"/>	<input type="checkbox"/>	Version	0.0	0.0	0.0	0.0
ACDC Output	<input type="checkbox"/>	<input type="checkbox"/>	<input type="checkbox"/>	<input type="checkbox"/>	AB voltage	0.0	0.0	0.0	0.0
Hardware enable	<input type="checkbox"/>	<input type="checkbox"/>	<input type="checkbox"/>	<input type="checkbox"/>	BC voltage	0.0	0.0	0.0	0.0
Input over voltage	<input type="checkbox"/>	<input type="checkbox"/>	<input type="checkbox"/>	<input type="checkbox"/>	AC voltage	0.0	0.0	0.0	0.0
Input under voltage	<input type="checkbox"/>	<input type="checkbox"/>	<input type="checkbox"/>	<input type="checkbox"/>	Output voltage	0.0	0.0	0.0	0.0
Input phase loss	<input type="checkbox"/>	<input type="checkbox"/>	<input type="checkbox"/>	<input type="checkbox"/>	Output current	0.0	0.0	0.0	0.0
Input phase unbalance	<input type="checkbox"/>	<input type="checkbox"/>	<input type="checkbox"/>	<input type="checkbox"/>	Temperature	0.0	0.0	0.0	0.0
Input frequency exception	<input type="checkbox"/>	<input type="checkbox"/>	<input type="checkbox"/>	<input type="checkbox"/>	Alarm count	0	0	0	0
Output over voltage	<input type="checkbox"/>	<input type="checkbox"/>	<input type="checkbox"/>	<input type="checkbox"/>	Type				
Output over current	<input type="checkbox"/>	<input type="checkbox"/>	<input type="checkbox"/>	<input type="checkbox"/>					
Output under voltage	<input type="checkbox"/>	<input type="checkbox"/>	<input type="checkbox"/>	<input type="checkbox"/>					
short circuit	<input type="checkbox"/>	<input type="checkbox"/>	<input type="checkbox"/>	<input type="checkbox"/>					
Error	<input type="checkbox"/>	<input type="checkbox"/>	<input type="checkbox"/>	<input type="checkbox"/>					
Temperature exception	<input type="checkbox"/>	<input type="checkbox"/>	<input type="checkbox"/>	<input type="checkbox"/>					
Software enable	<input type="checkbox"/>	<input type="checkbox"/>	<input type="checkbox"/>	<input type="checkbox"/>					
Communication timeout	<input type="checkbox"/>	<input type="checkbox"/>	<input type="checkbox"/>	<input type="checkbox"/>					

Laser IP: 192.168.0.10 State: **Connected** Diagnostics Version: V1.21

Figure 16 ACDC module menu

#### 4.7.9 DCDC module

The DCDC module page contains the relevant status information of the DCDC module, and the refresh interval of the status information does not exceed 100ms.

RFL-C2000S-HP /RFL-C3000S-HP /RFL-C4000S-HP/RFL-C6000S-HP

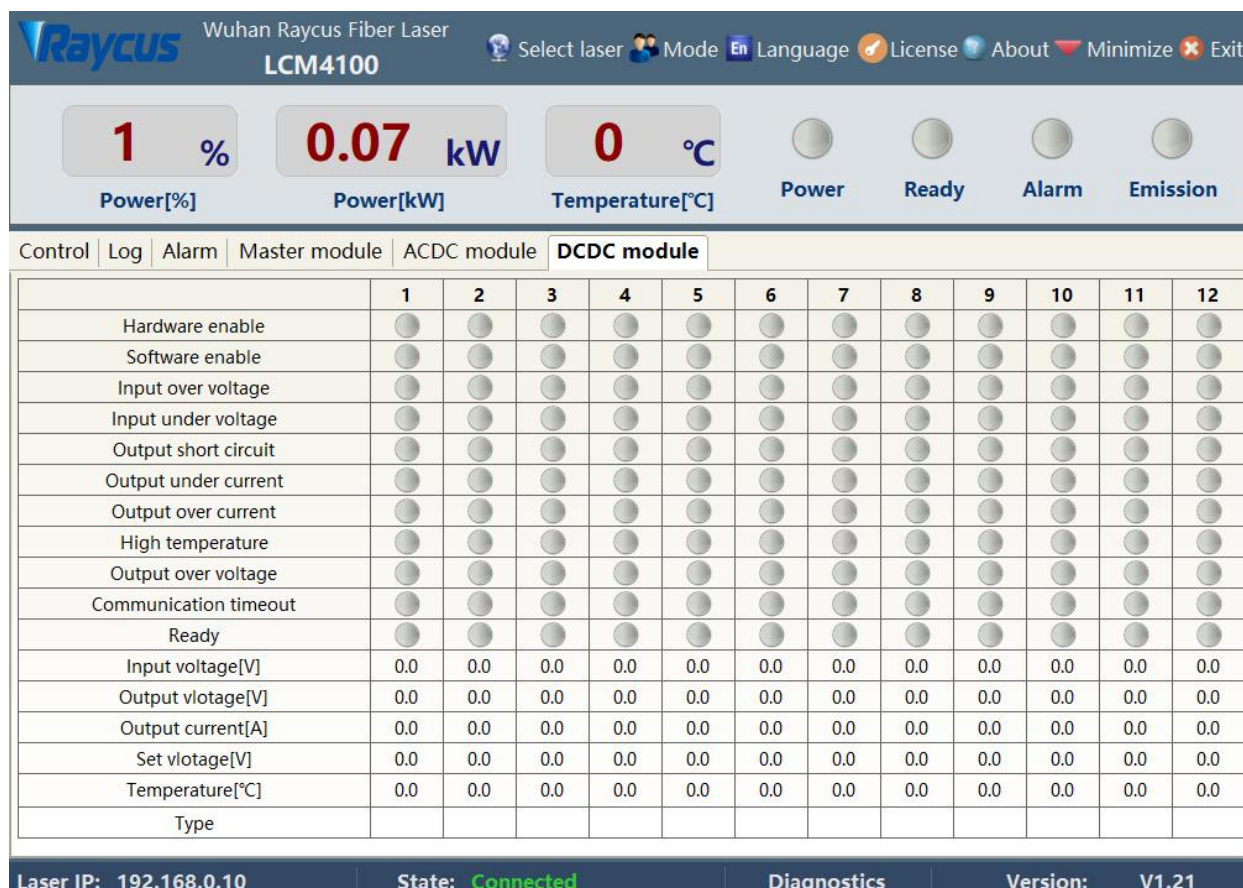

Figure 17 DCDC module menu

## 4.8 Control mode selection

### a) AD mode

Table 14 AD mode settings

AD mode	Laser power
ON	INTERFACE 24-pin 12, 14-pin analog voltage 0~10V 0V——0% 10——100%
OFF	The Raycus software sets the power percentage or the communication command "SDC" setting

### b) External enable

Table 15 External enable settings

External enable	Laser enable
ON	The Positive edge of pins 18 and 20 of INTERFACE 24 pins
OFF	The laser enable button of the Raycus software or the communication command "EMON/EMOFF"

### c) External emit laser

Table 16 External enable settings

External emit laser	Laser emission
---------------------	----------------

RFL-C2000S-HP /RFL-C3000S-HP /RFL-C4000S-HP/RFL-C6000S-HP

ON	The Positive edge of pins 15 and 16 of INTERFACE 24 pins
OFF	The laser emission button or communication command of the Raycus software “EMON/EMOFF”

**4.8.1 Full external control mode control mode wiring diagram (external analog/external enable/external emit laser)**

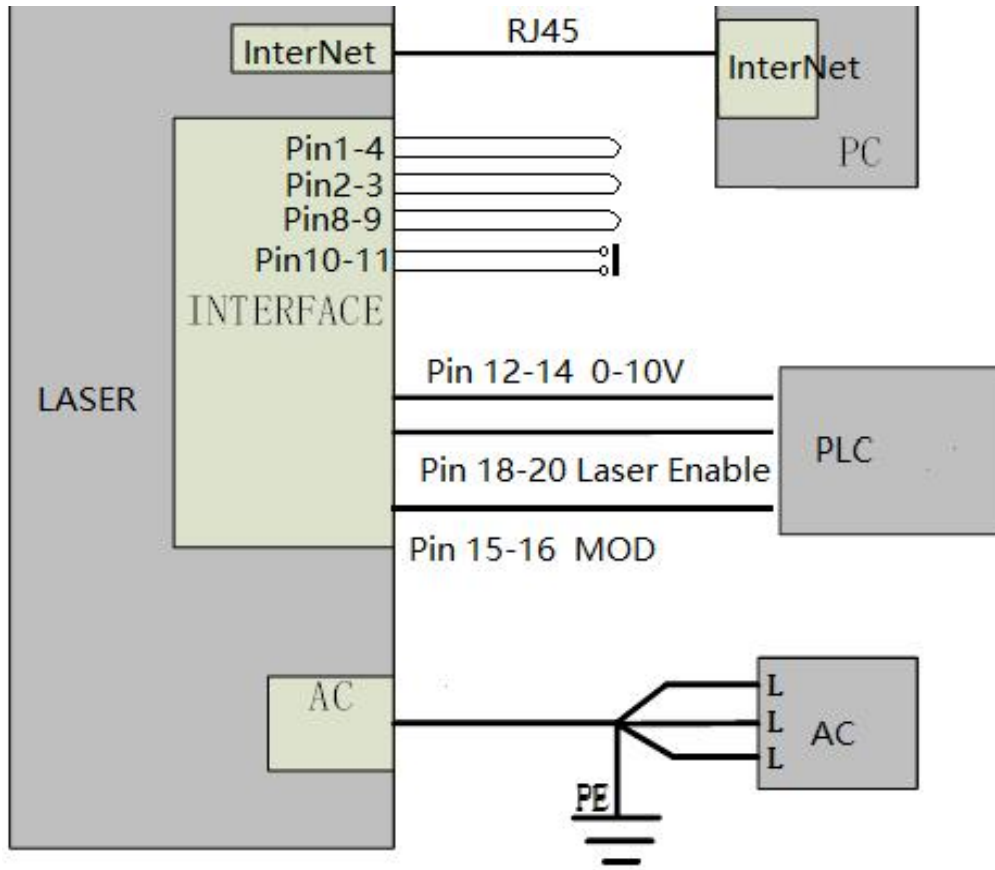

Figure 18 External control wiring diagram

RFL-C2000S-HP /RFL-C3000S-HP /RFL-C4000S-HP/RFL-C6000S-HP

### 4.8.2 Control Sequence Diagram

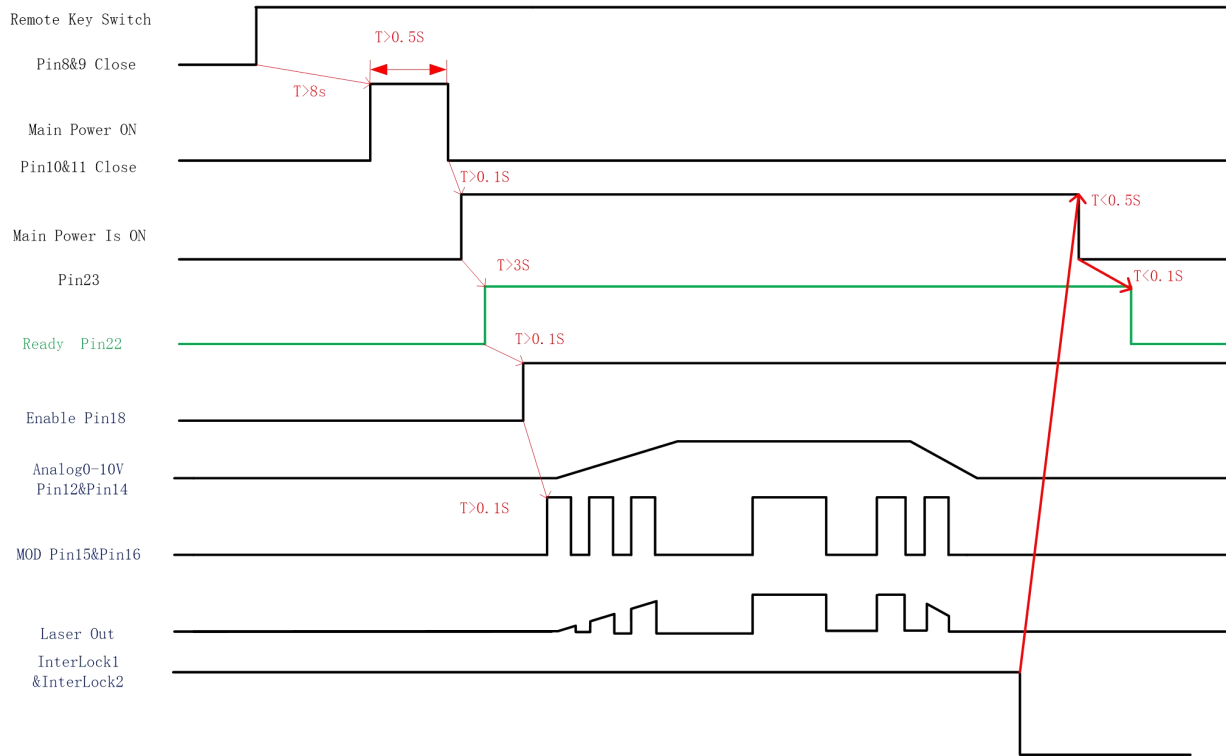

Figure 19 Control Timing Diagram

### 4.9 Red guide beam control

Table 17 Red guide beam external control mode

Red guide beam external control	
ON	17 pin of INTERFACE: Positive edge - turn on the red guide beam; Negative edge - turn off the red guide beam.
OFF	Host software: Red guide beam ON - turn on the red guide beam; Red guide beam OFF - turn off the red guide beam.

## 4.10 Laser power slow rise and fall mode

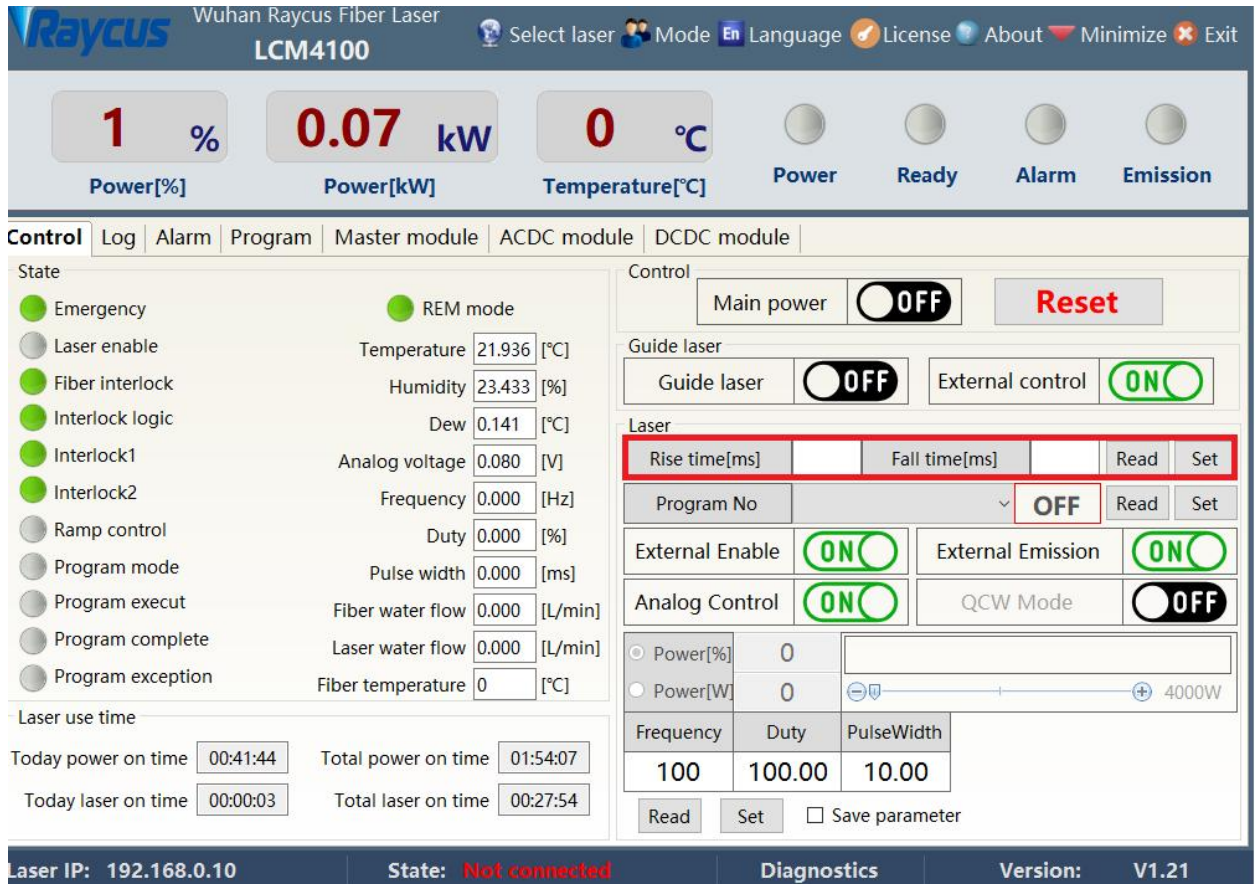

Figure 20 Slow rise and fall parameter menu

In the slow rise and fall setting, if any parameter is not 0, the laser will automatically enter the rise and fall mode, and if all the rise and fall parameters are 0, the rise and fall mode will be automatically turned off.

After the slow rise and fall mode is turned on, the laser performs the ramp-up program to the target power according to the set ramp-up time after the start of laser emission, and executes the ramp-down program to power 0 according to the set ramp-down time after turning off the laser.

## 4.11 Programming Mode (Waveform Editing)

### 4.11.1 Programming mode enabling method

In programming mode, the laser has waveform editing, storage and recall functions.

Table 18 Programming mode enable method

Programming mode	The laser emission is determined by the edited waveform
	Voltage of pins 15 and 16 of INTERFACE 24 pin: Rising edge - start the program to start executing Falling edge - terminate the program running
Closed: the current program number is 0	Do not execute programming

When the current program number of the laser is not 0, the laser is running in programming mode. Please use the Raycus software provided by Raycus to edit the waveform, and select the pre-running program number. The output waveform of the laser is determined by the edited waveform. When all the laser emission conditions are satisfied, the relationship between the laser emission and the programming waveform in the programming mode is as follows:

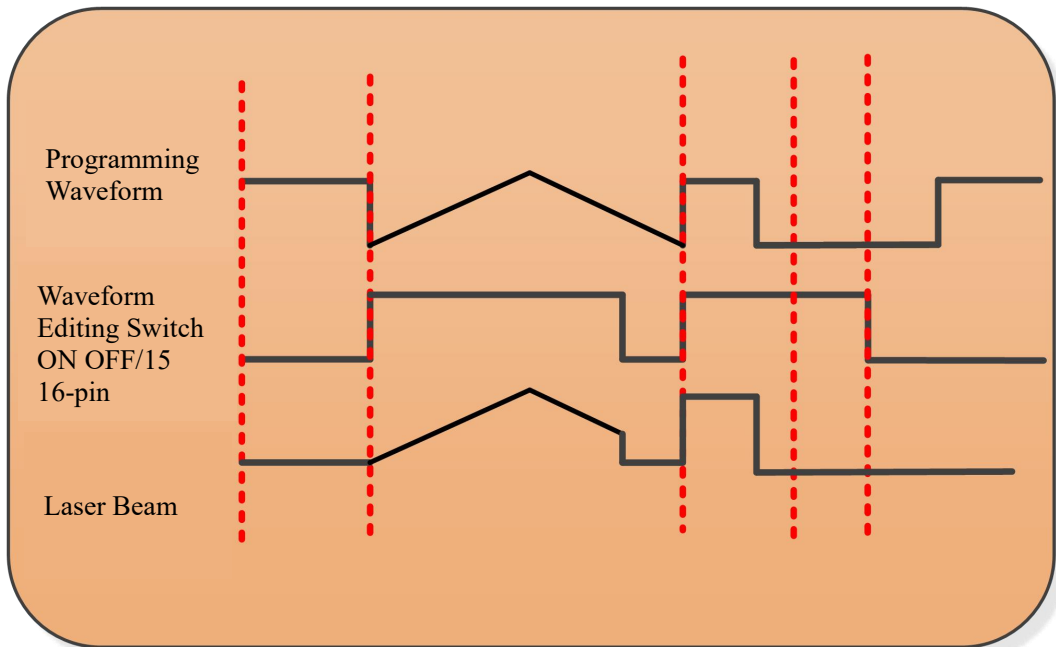

Figure 21 The relationship between laser emission and programming waveform in programming mode

#### 4.11.2 Programming setting menu (waveform editing)

Check "Display Programming Mode" in the "Mode Selection" of the Raycus software.

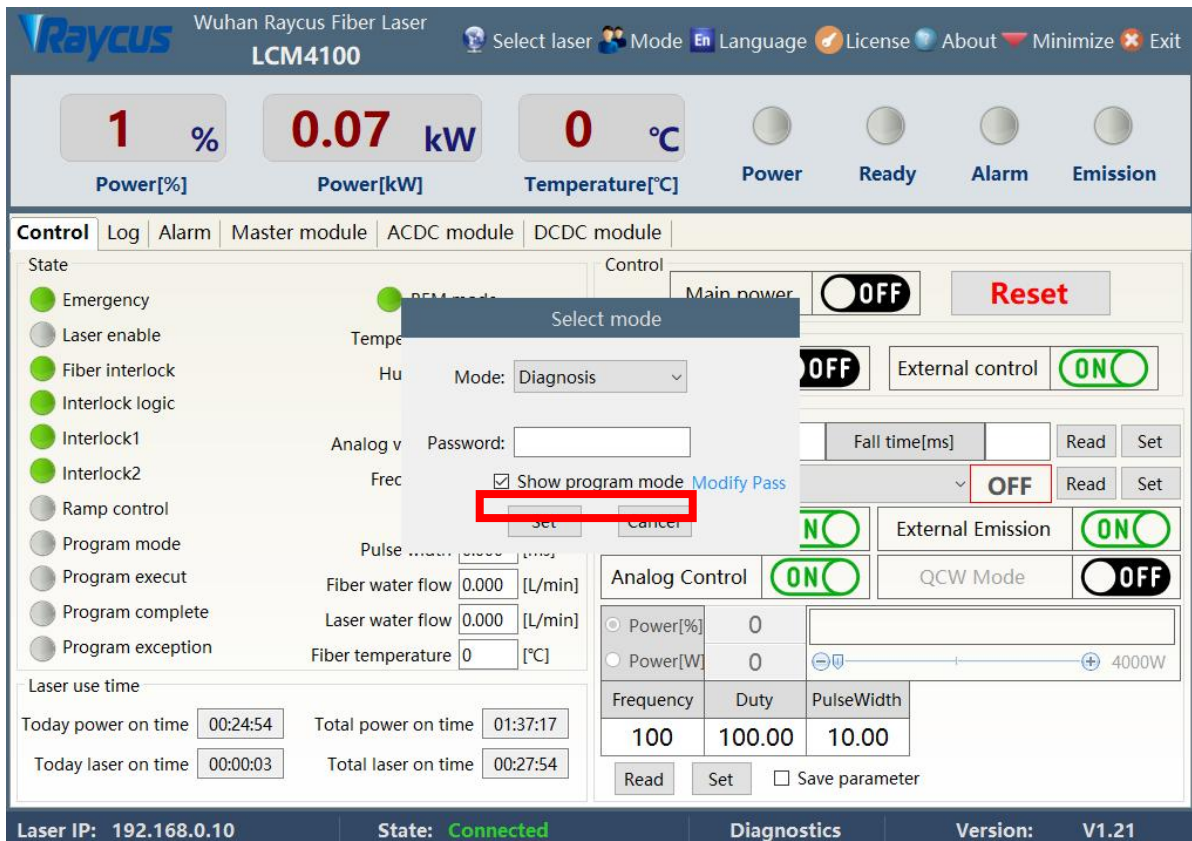

Figure 22 Check the display programming mode menu

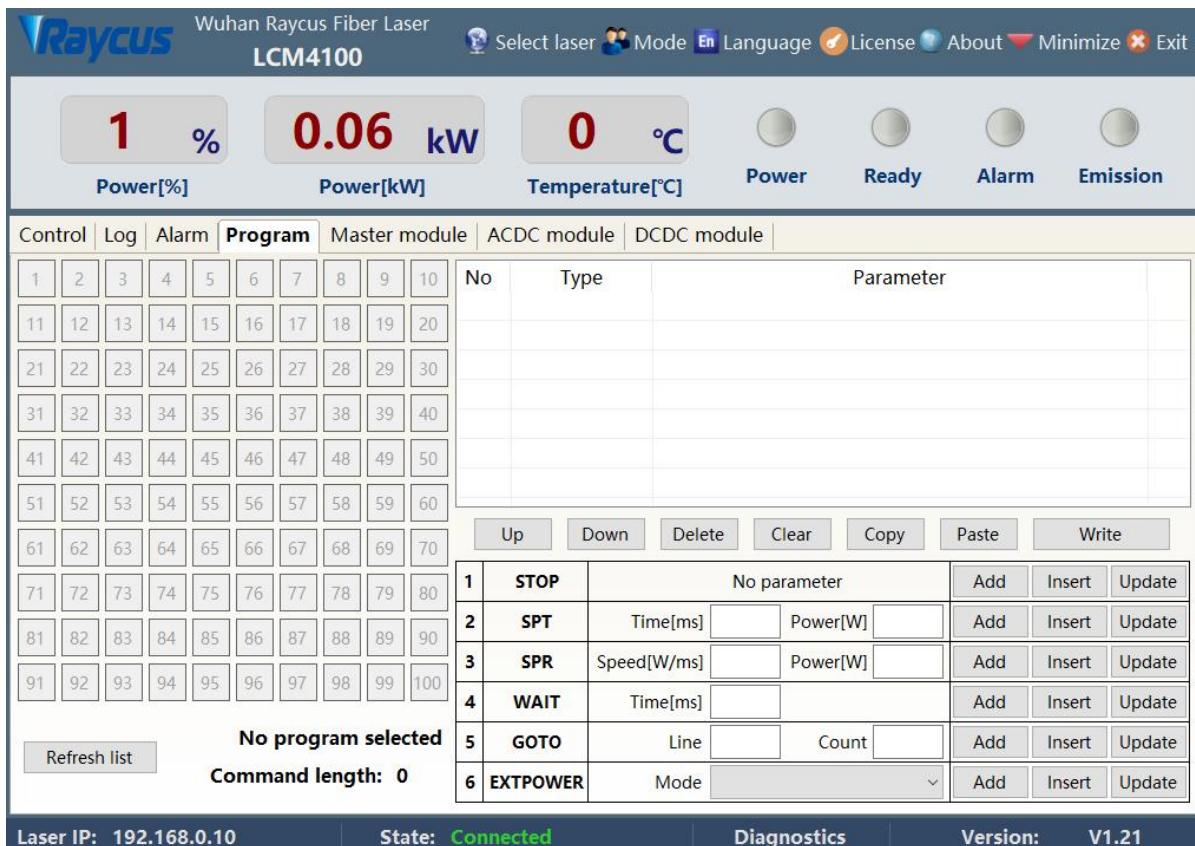

Figure 23 Programming mode menu

RFL-C2000S-HP /RFL-C3000S-HP /RFL-C4000S-HP/RFL-C6000S-HP

### 4.11.3 View the number of waveform

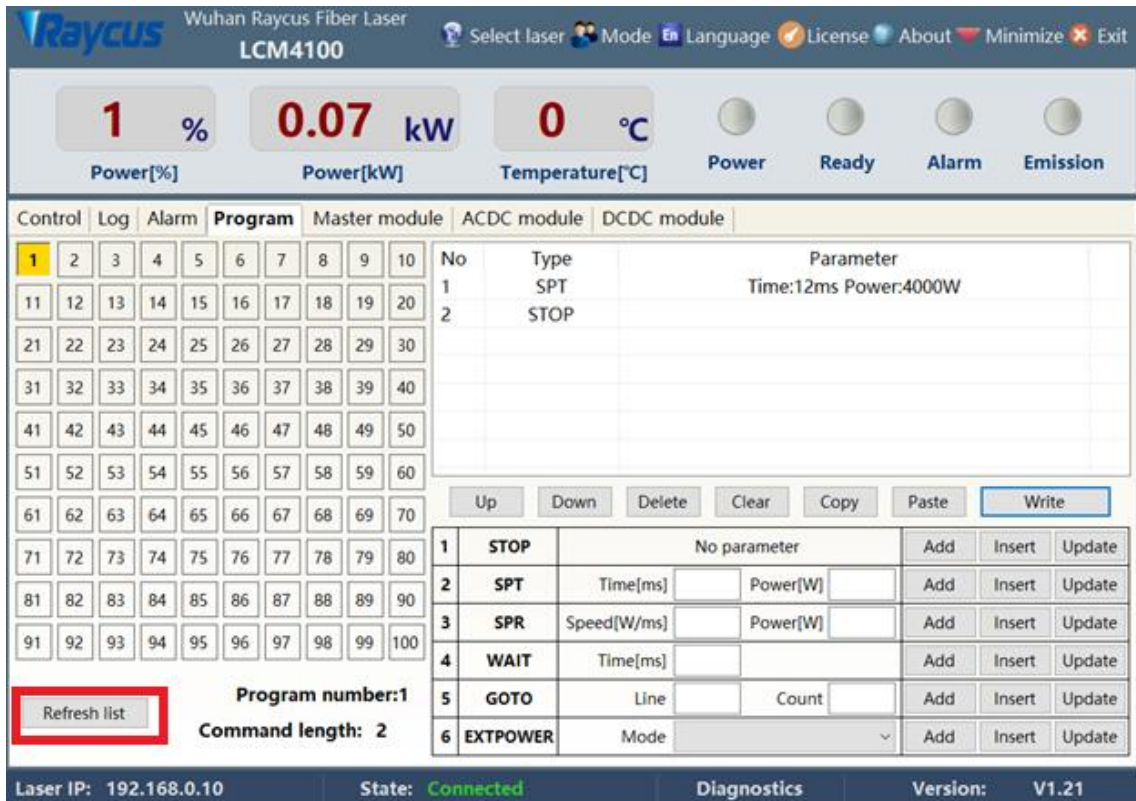

Figure 24 View the number of waveform bars

Click the "Refresh program list" button, the software will automatically list the number of waveform that have been saved, green indicates that this item has a program, and white indicates that this item is empty.

RFL-C2000S-HP /RFL-C3000S-HP /RFL-C4000S-HP/RFL-C6000S-HP

#### 4.11.4 View waveform content

The screenshot shows the Raycus LCM4100 control software interface. At the top, there are status indicators for Power[%] (1), Power[kW] (0.07), and Temperature[°C] (0). Below these are buttons for Power, Ready, Alarm, and Emission. The main interface is divided into tabs: Control, Log, Alarm, Program, Master module, ACDC module, and DCDC module. The 'Program' tab is active, displaying a grid of 100 program slots (1-100) and a list of parameters. A 'Read success' dialog box is overlaid on the interface, indicating that the selected program has been read successfully. The 'Program' list includes commands like STOP, SPT, SPR, WAIT, GOTO, and EXTPOWER, each with associated parameters and 'Add', 'Insert', and 'Update' buttons.

No	Type	Parameter
1	SPT	Time:12ms Power:4000W
2	STOP	

Figure 25 View waveform content

Click the waveform number to be read with the left mouse button, and the program will automatically list the original waveform list.

RFL-C2000S-HP /RFL-C3000S-HP /RFL-C4000S-HP/RFL-C6000S-HP

### 4.11.5 Clear all waveform

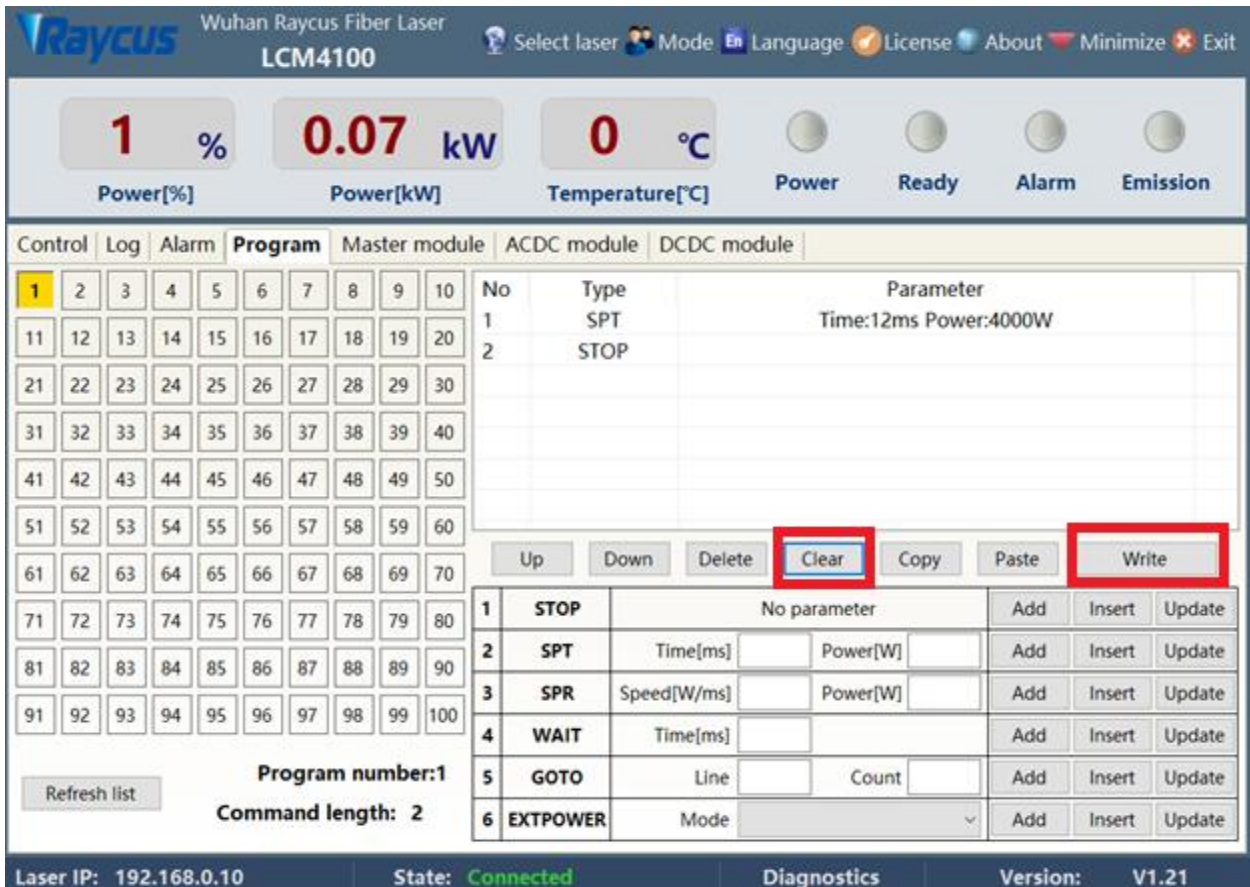

Figure 26 Clear the waveform

Click the program number that needs to be cleared, click "Clear", and then click "Write to Laser", the software will clear the waveform stored in the current laser.

RFL-C2000S-HP /RFL-C3000S-HP /RFL-C4000S-HP/RFL-C6000S-HP

### 4.11.6 Edit waveform

First left click on the pre-edited waveform number:

The screenshot shows the Raycus LCM4100 control software interface. At the top, there are status indicators for Power [%] (1%), Power [kW] (0.07), and Temperature [°C] (0). Below these are buttons for Power, Ready, Alarm, and Emission. The main interface is divided into several sections:

- Control Panel:** Includes buttons for Control, Log, Alarm, Program, Master module, ACDC module, and DCDC module.
- Waveform Grid:** A grid of 100 cells (10 columns by 10 rows) for editing waveform commands. Cell 1 is highlighted.
- Command Table:** A table listing existing commands with columns for No., Type, and Parameter.
 

No.	Type	Parameter
1	SPT	Time:12ms Power:4000W
2	STOP	
- Command List:** A list of command types with their parameters and actions (Add, Insert, Update).
 

No.	Command Type	Parameters	Add	Insert	Update
1	STOP	No parameter			
2	SPT	Time[ms] <input type="text"/> Power[W] <input type="text"/>			
3	SPR	Speed[W/ms] <input type="text"/> Power[W] <input type="text"/>			
4	WAIT	Time[ms] <input type="text"/>			
5	GOTO	Line <input type="text"/> Count <input type="text"/>			
6	EXTPOWER	Mode <input type="text"/>			
- Bottom Status Bar:** Shows Laser IP: 192.168.0.10, State: Connected, Diagnostics, and Version: V1.21.

Figure 27 Edit waveform

Select Command under Command Type, then write the command and click Add.

RFL-C2000S-HP /RFL-C3000S-HP /RFL-C4000S-HP/RFL-C6000S-HP

The screenshot shows the Raycus LCM4100 control software interface. At the top, there are status indicators for Power [%] (1), Power [kW] (0.07), and Temperature [°C] (0). Below these are buttons for Power, Ready, Alarm, and Emission. The main area is divided into tabs for Control, Log, Alarm, Program, Master module, ACDC module, and DCDC module. The Program tab is active, showing a grid of command slots (1-100) and a list of commands. The command list includes: 1 STOP, 2 SPT, 3 SPR, 4 WAIT, 5 GOTO, and 6 EXTPOWER. The 'Add' button for each command is highlighted with a red box. The status bar at the bottom shows Laser IP: 192.168.0.10, State: Connected, Diagnostics, and Version: V1.21.

No	Type	Parameter
1	SPT	Time:12ms Power:4000W
2	STOP	

No	Type	Parameter	Add	Insert	Update
1	STOP	No parameter	Add	Insert	Update
2	SPT	Time[ms] Power[W]	Add	Insert	Update
3	SPR	Speed[W/ms] Power[W]	Add	Insert	Update
4	WAIT	Time[ms]	Add	Insert	Update
5	GOTO	Line Count	Add	Insert	Update
6	EXTPOWER	Mode	Add	Insert	Update

Figure 28 Select command

The command just now appears in the program list on the left. After editing all the commands, click "Write to Laser".

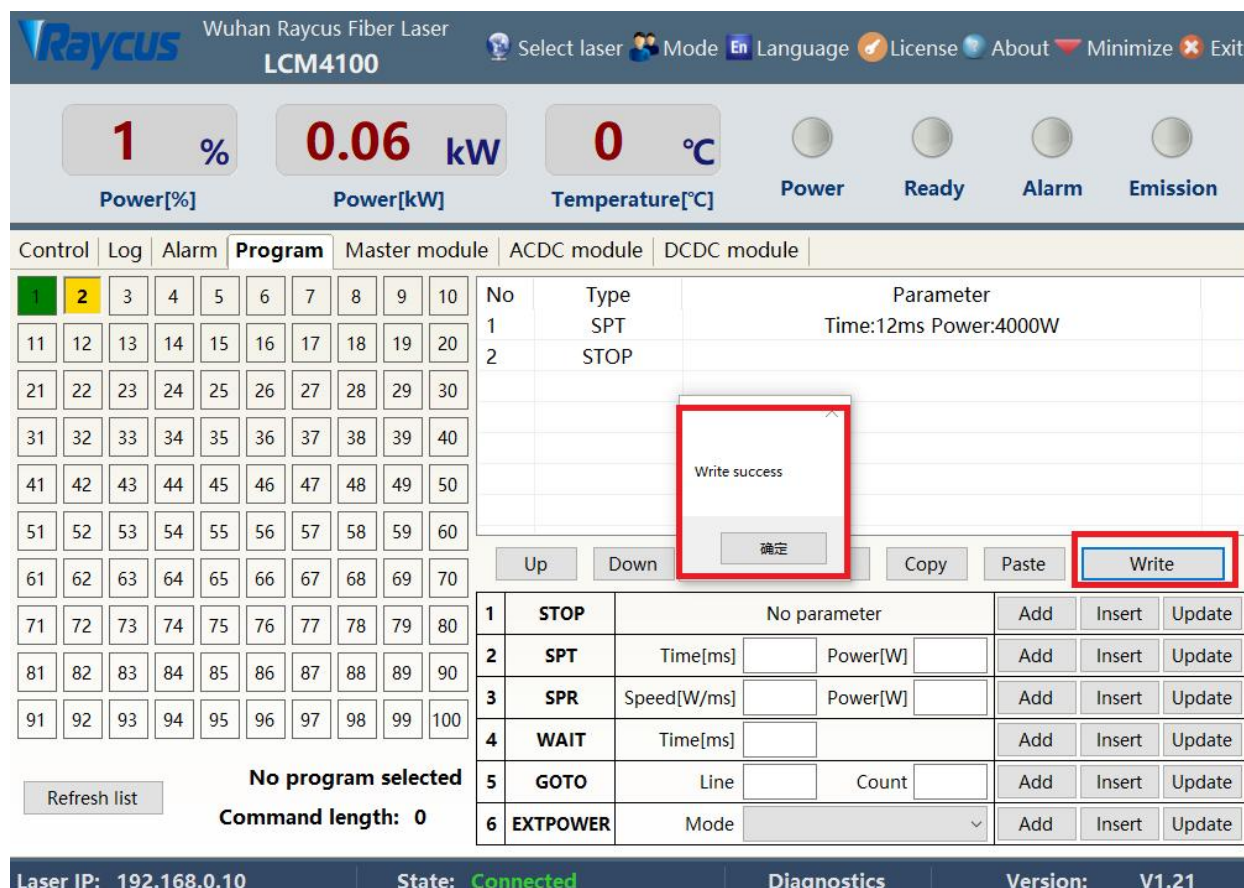

Figure 29 Waveform written successfully

Click "Refresh program list" again, and the newly added waveform number will turn green, indicating that the writing is successful. Click the program number, it will show that the read is successful:

### 4.11.7 Command interpretation

Table 19 detailed explanation of waveform command word

Command code (1 byte)	Parameter 1 (2 bytes)	Parameter 2 (4 bytes)	Description
1	STOP	None	The end-of-program command, which must be the last entry for each program
2	SPT	0-65000 (ms)	It takes time for parameter 1 to change the power to parameter 2
3	SPR	0-65000 (W/ms)	Change the power to parameter 2 by the rate of change of the power of parameter 1

RFL-C2000S-HP /RFL-C3000S-HP /RFL-C4000S-HP/RFL-C6000S-HP

4	WAIT	1	Wait time	0-65000ms(int)		
5	GOTO	0-99	line	0-10000	The number of times to jump to that row	The number of times the loop jumps to the line number
6	EXTPower	1	0-10V			

#### 4.12 Steps of close

Turn off the lasers in the following orders:

- a) Turn off the laser;
- b) Disconnect the 1/4 and 2/3 pins of the CTRL-INTERFACE;
- c) Disconnect the pins 8/9 of the CTRL-INTERFACE;
- d) Turn off the chiller;
- e) Disconnect the air switch;
- f) Close the head protection cap.

## 5.Common alarms and handling measures

### 5.1 Alarm display

Connect to the computer and turn on the Raycus software, all alarm states of the laser can be displayed on the Raycus software menu, as shown in Figure 30. The laser will alarm when the internal temperature of the laser is abnormal, the power is abnormal, the scattered light is abnormal, the power supply is abnormal, the condensation is abnormal, the flow is abnormal, etc.

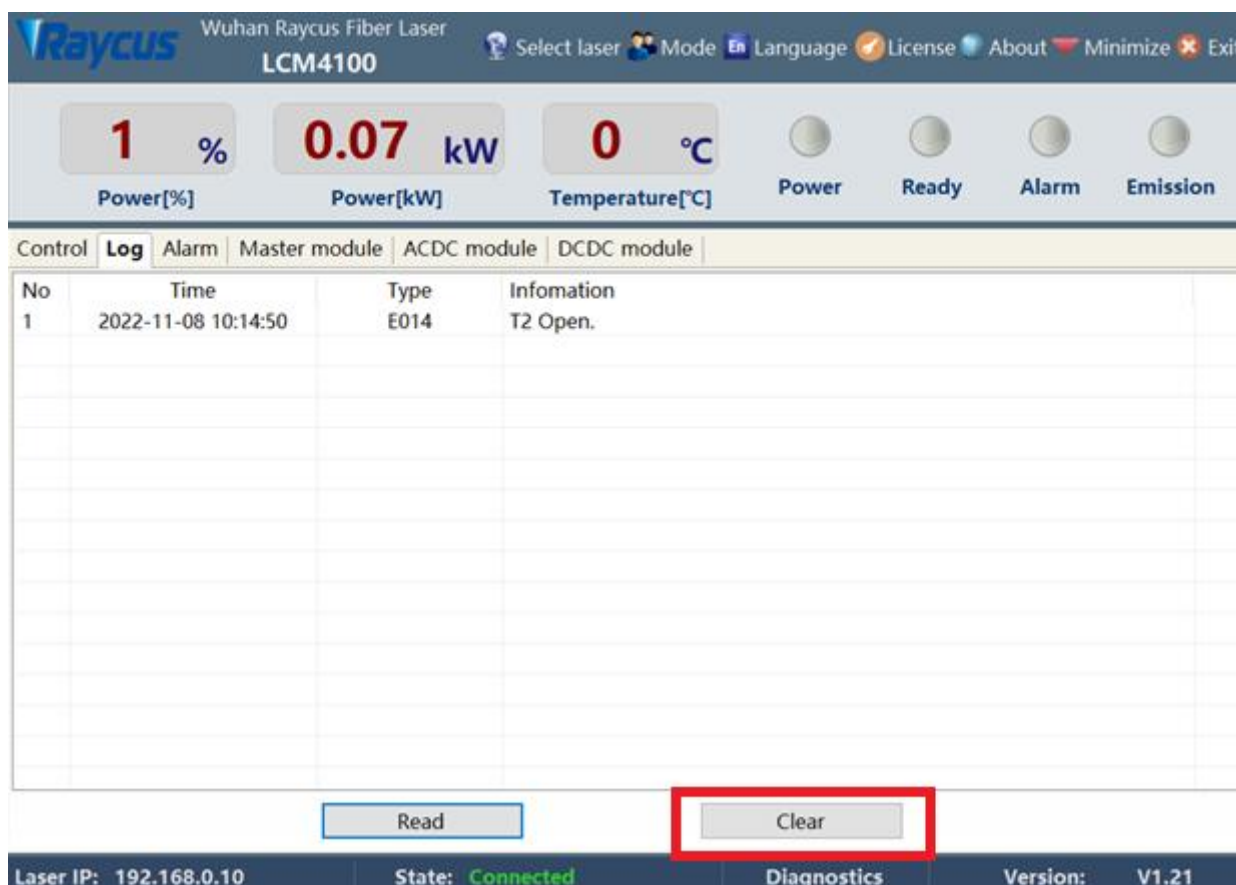

Figure 30 The main menu of the Raycus software

When the laser is running, any alarm occurs (except for the Interlock abnormality), the Raycus software menu will display the alarm, and the ALARM light (yellow one) on the front panel of the laser will light, and the laser will stop emitting light and lock.

When the Interlock abnormality occurs, the “laser output Ready” signal is low, and at the same time, the software indicates the Interlock abnormality, but the laser does not lock and the ALARM light (yellow) does not light up. Immediately after Interlock is normal, the laser will output a Ready signal to a high level.

## 5.1 Alarm Handling

Typical laser alarm descriptions and possible solutions are as follows:

Table 20 Laser alarm description and possible solutions

Alarm type	alarm description and possible solutions
<p>T1/T2 Alarm (Temperature alarm - low temperature alarm and high temperature alarm)</p>	<p><b>Alarm Description:</b></p> <p>Laser low temperature/high temperature alarm, which occurs when the sensor inside detects an abnormal temperature inside the laser. A high temperature alarm is generated when the temperature of the monitoring point exceeds the set upper limit, and a low temperature alarm is generated when the set lower limit is exceeded.</p> <p><b>Possible solutions:</b></p> <p>In the event of a high temperature alarm, please check whether the water cooling system is turned on normally, whether the water temperature setting is correct, whether the chiller is working normally, whether the water connection is abnormal, etc. When the water cooling system is working normally and the water temperature drops below 30°C, please restart the laser to try.</p> <p>In the case of low temperature alarm, please check whether the actual water temperature of the chiller is too low. In addition, too low ambient temperature may also cause a low temperature alarm when the laser start at a cold machine state. If the above situation occurs, you need to wait until the chiller water temperature rises above 10 °C, and then restart the laser to try.</p>
<p>Hum Alarm (Condensation alarm)</p>	<p><b>Alarm Description:</b></p> <p>Laser internal condensation alarm means the laser detected the current laser internal dew point temperature &lt; 22 °C, there is a risk of condensation.</p> <p><b>Possible solutions:</b></p> <p>Stop using the laser immediately. Please follow the operation requirements to induct cold and dry air from the CDA interface, drain moist air from the cabinet, or improve the working environment of the laser so that the ambient temperature is lower than the internal temperature of the laser, it is recommended to build a separate air-conditioned room for the laser.</p>

<p>LaserWaterflow (Laser water flow alarm)</p>	<p><b>Alarm Description:</b> Laser water flow alarm, the laser internally detected that the current water flow is lower than the required value, there is a safety risk.</p> <p><b>Possible solutions:</b> Stop using the laser immediately. Please follow the laser operation requirements of [Section 3.3 Cooling System Installation and Requirements], check the output model and working status of the laser water cooler, and clean the laser inlet water filtration assembly. It is recommended to clean the water cooler and inlet filter assembly and replace the cooling water regularly.</p>
<p>ScatteredLightAlarm</p>	<p><b>Alarm Description:</b> Scattered light alarm, when the ambient light intensity of the laser exceeds the set value, the scattered light alarm is generated, and the laser light output function is locked (not unlockable). Scattered light alarms only occur when the laser is emitted.</p> <p><b>Possible solutions:</b> Restart the laser, check the red light status indicated by the laser, read the scattered light monitoring voltage value through the "slave module" of the Raycus software, and contact Raycus.</p>
<p>Laser Power Alarm</p>	<p><b>Alarm Description:</b> Power alarm, power alarm is generated when the output power of the laser cannot reach the set value. The power alarm only occurs when the laser is emitted.</p> <p><b>Possible solutions:</b> Check the red light status and contact Raycus.</p>
<p>ACDCAlarm (Power alarm)</p>	<p><b>Alarm Description:</b> Laser power alarm, laser power supply failure or sudden power supply restart of the power supply system may cause this alarm.</p> <p><b>Possible solutions:</b> Check whether the input AC voltage is normal, restart the laser to try if input AC voltage is normal, and contact Raycus if the alarm continues to occur.</p>

Current Driver Alarm (The current driver board alarm)	<p><b>Alarm Description:</b></p> <p>The current drive board alarm, which occurs when the constant current drive board inside is abnormal.</p> <p><b>Possible solutions:</b></p> <p>Try rebooting the laser and contact Raycus if alarms continue to occur.</p>
---	--

In addition to the above alarms, if there is any problem or alarm in the using the laser, Please contact Raycus for help.

## 6.Warranty, Return and Maintenance

### 6.1 General Warranty

Raycus warrants that all Raycus fiber laser products are conformed to applicable product specifications under normal use and are free from defects in materials and workmanship.

The warranties start on the date of shipment from Raycus for a period of time as set forth in the applicable purchase contracts or product specifications. Raycus has the right to selectively repair or replace any product that proves to be defective in materials and workmanship selectively during the warranty period. Only products with particular defects are under warranty. Raycus reserves the right to issue a credit note for any defective products produced in normal conditions.

### 6.2 Limitations of Warranty

The warranty does not cover the maintenance or reimbursement of our product of which the problem results from tampering, disassembling, misuse, accident, modification, unsuitable physical or operating environment, improper maintenance, damages due to excessive use or not following the instructions caused by those who are not from Raycus. The customer has the responsibility to understand and follow this instruction to use the device. Any damage caused by fault operating is not warranted. Accessories and fiber connectors are excluded from this warranty.

According to the warranty, client should write to us within 31 days after the defect is discovered. This warranty does not involve any other party, including specified buyer, end-user or customer and any parts, equipment or other products produced by other companies.



◆ **WARNING:** It is the customer's responsibility to understand and follow operating instructions in this User Guide and specifications prior to operation-failure to do so may void this warranty. Accessories and delivery fiber and connectors are not covered by this warranty.

### 6.3 Service and Repair

Do not open the device. There are no user serviceable parts, equipment or assemblies for user in this product. All service and maintenance shall be performed by qualified Raycus personnel.

Please contact Raycus as soon as possible when problems under warranty about maintenance happened to the product.

All repaired or replacement products must be placed in the original packaging box provided by Raycus, otherwise Raycus will have the right not to repair any product damage caused by the package.

When you receive Raycus products, please check whether the products are intact and undamaged in time, and contact the carrier or Raycus in time if there is any problem.

### 6.4 Scrapping Requirements

If the fiber laser has reached the service life or has serious failure and has no repair value or meets other scrapping conditions, the recycling treatment shall meet the "Regulations on the Administration of Recycling and Treatment of Waste Electrical and Electronic Products".

**We reserve the right to make changes in design or constructions of any of our products at anytime without incurring any obligation to make changes or install the same on units previously purchased.**

**All the items about warranty and service above provided by Raycus are for uses' reference; formal contents about warranty and service are subject to the contract.**